SECTION 8A

SEAT BELTS

CAUTION: Disconnect the negative battery cable before removing or installing any electrical unit or when a tool or equipment could easily come in contact with exposed electrical terminals. Disconnecting this cable will help prevent personal injury and damage to the vehicle. The ignition must also be in B unless otherwise noted.

TABLE OF CONTENTS

Description and Operation	8A-2	Repair Instructions	8A-5
Driver Seat Belt Warning	8A-2	On-Vehicle Service	8A-5
Three-Point Pretensioner Front Seat Belt (W/EUROPE Only)	8A-2	Three-Point WLR/ELR Front Seat Belt	8A-5
Three-Point WLR Front Seat Belt	8A-2	Three-Point Pretensioner Front Seat Belt (W/EUROPE Only)	8A-6
Three-Point ELR Front Seat Belt	8A-2	Front Seat Belt Buckle	8A-8
Three-Point ELR Rear Outboard Seat Belt	8A-2	Three-Point ELR Rear Outboard Seat Belt ...	8A-8
Two-Point Lap Rear Center Seat Belt	8A-2	Two-Point Lap Rear Center Seat Belt	8A-10
Operational and Functional Checks	8A-2	Specifications	8A-11
Component Locator	8A-3	Fastener Tightening Specifications	8A-11
Front and Rear Seat Belt	8A-3	Schematic and Routing Diagrams	8A-12
Diagnostic Information and Procedures	8A-4	Driver Seat Belt Warning	8A-12
Seat Belt Warning Lamp is Inoperative	8A-4		

DESCRIPTION AND OPERATION

DRIVER SEAT BELT WARNING

The driver's safety belt incorporates a safety belt reminder light in the instrument cluster to remind the driver if the safety belt is not fastened when the ignition is turned ON.

THREE-POINT PRETENSIONER FRONT SEAT BELT (W/EUROPE ONLY)

The pretensioner front seat belt is optional. It contains a electrically-controlled pyrotechnical retractor, which reduces seat belt slack when it is activated in a head-on or angled front collision. The pretensioner front seat belt must be replaced after an accident that causes its activation.

THREE-POINT WLR FRONT SEAT BELT

The three-point web locking retractor (WLR) seat belt will limit the movement of the driver and offer better protection in an accident.

THREE-POINT ELR FRONT SEAT BELT

The three-point emergency locking retractor (ELR) front seat belt is always unlocked, allowing the passenger freedom of movement, except in emergencies (rapid deceleration, rapid acceleration, or hard cornering maneuvers).

THREE-POINT ELR REAR OUTBOARD SEAT BELT

The rear outboard seating positions use the three-point emergency locking retractor (ELR) seat belts. The three-point emergency locking retractor (ELR) seat belt

is always unlocked, allowing the passenger freedom of movement, except in emergencies (rapid deceleration, rapid acceleration, or hard cornering maneuvers).

TWO-POINT LAP REAR CENTER SEAT BELT

The two-point lap rear center seat belt is a single continuous length of webbing. The webbing is routed from the anchor through a latch plate and into a single retractor.

OPERATIONAL AND FUNCTIONAL CHECKS

Caution:

- **Keep sharp objects and potentially damaging objects away from the seat belts.**
 - **Avoid bending or damaging any portion of the buckle or the latch plate.**
 - **Do not bleach or dye the belt webbing. Use only mild soap and water in order to clean the belts.**
 - **When installing the seat belt anchor bolts and the screws, start the bolts and the screws by hand in order to prevent crossthreading.**
 - **Do not attempt any repairs on the retractor mechanisms or the covers. Replace any defective assemblies with new assemblies.**
 - **Replace any belts that are cut or damaged in any way.**
1. Inspect all seat belt anchor bolts and the screws in order to verify that they are secure.
 2. Inspect the seat belt buckle. The buckle must lock and unlock easily.
 3. After inserting the latch into the buckle, tug sharply on the belt. The buckle must remain locked.
 4. Fully extend the shoulder belt portion to make sure that there is no twisting or tears in the belt.
 5. Let the shoulder belt retract fully. The belt should retract easily.

COMPONENT LOCATOR

FRONT AND REAR SEAT BELT

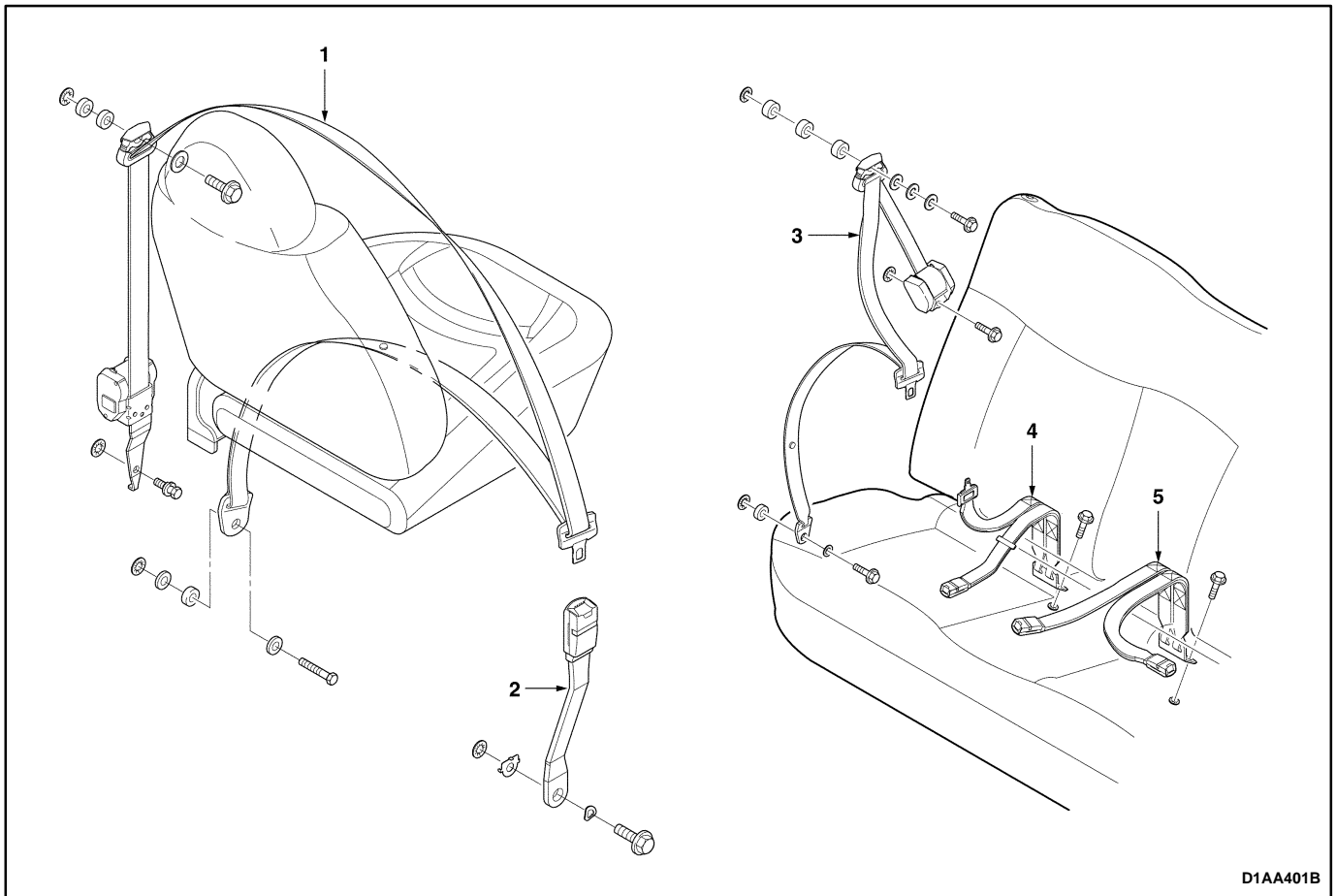

D1AA401B

1. Front Seat Belt
2. Front Seat Belt Buckle
3. Rear Seat Belt (Three-Point)
4. Rear Seat Belt (Two-Point) / Buckle (Three-Point)
5. Rear Seat Belt Buckle (Three-Point/Two-Point)

DIAGNOSTIC INFORMATION AND PROCEDURES**SEAT BELT WARNING LAMP IS INOPERATIVE**

Condition	Probable Cause	Correction
Seat Belt Warning Lamp is Inoperative	<ul style="list-style-type: none">● Fuse F1 is blown.	<ul style="list-style-type: none">● Replace the fuse F1.
	<ul style="list-style-type: none">● Seat belt warning lamp wiring harness is open circuit or a short circuit.	<ul style="list-style-type: none">● Repair the wiring harness.
	<ul style="list-style-type: none">● The continuity between the two terminals at the switch side of the connector is fail.	<ul style="list-style-type: none">● Replace the seat belt switch.
	<ul style="list-style-type: none">● The continuity between the terminal for the BLK wire and ground is fail.	<ul style="list-style-type: none">● Repair the open ground.
	<ul style="list-style-type: none">● The warning lamp bulb in the instrument cluster is blown.	<ul style="list-style-type: none">● Replace the warning lamp bulb.

REPAIR INSTRUCTIONS

ON-VEHICLE SERVICE

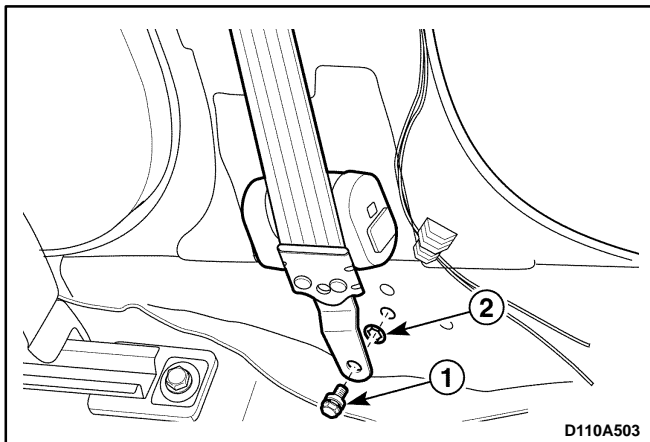
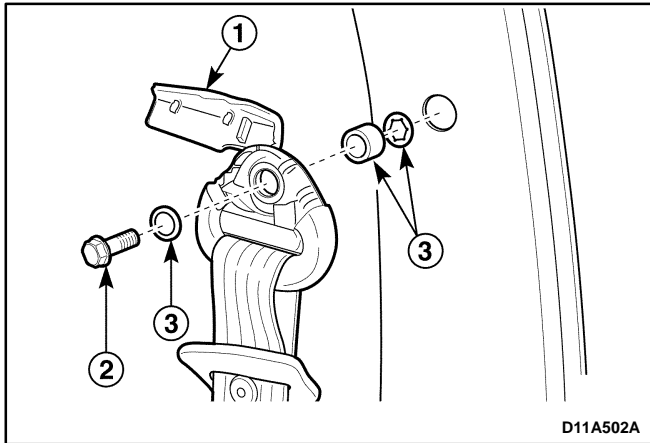
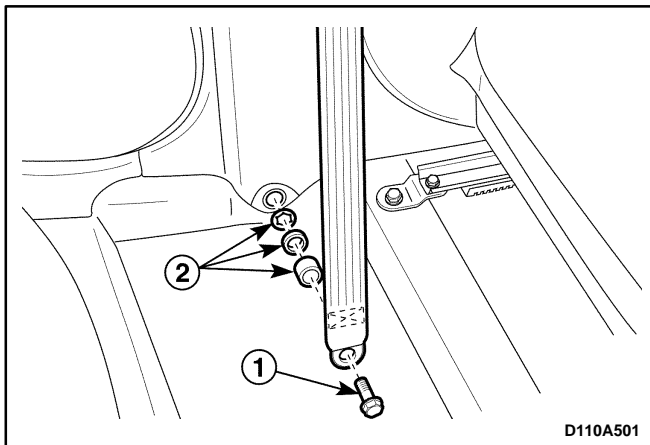

THREE-POINT WLR/ELR FRONT SEAT BELT

Removal Procedure

1. Slide the front seat forward and fold the seatback.
2. Remove the bolt on the lower B-pillar.
 - Remove the bolt (1).
 - Remove the spacer and the fiber washer (2).
 - Remove the plastic protector on the seat belt anchor.
3. Remove the lower B-pillar trim panel. Refer to *Section 9G, Interior Trim*.
4. Remove the bolt on the upper B-pillar.
 - Using a flathead screwdriver, open the bolt cap (1).
 - Remove the bolt (2).
 - Remove the spacer and the fiber washer (3).
5. Remove the seat belt retractor bolt.
 - Remove the floor carpet to be seen the retractor.
 - Remove the bolt (1).
 - Remove the fiber washer (2).
 - Remove the seat belt retractor.

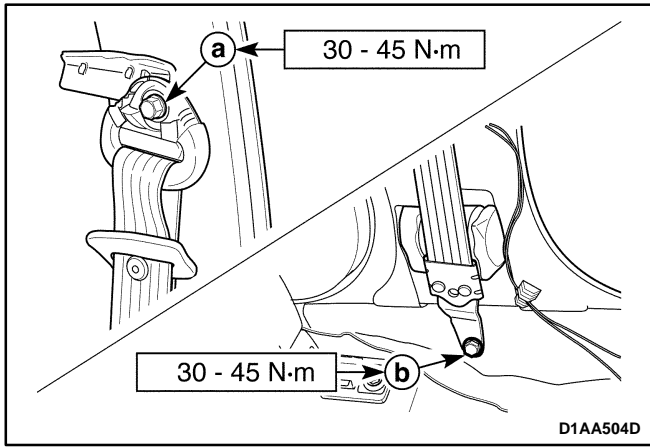

Installation Procedure

Notice: Dissimilar metals in direct contact with each other may corrode rapidly. Make sure to use the correct fasteners to prevent premature corrosion.

1. Install in the reverse order of removal.
2. Install the bolt on the upper B-pillar.

Tighten

Tighten the seat belt upper bolt to 30–45 N•m (22–33 lb-ft).

- a. Seat belt upper bolt.

3. Install the seat belt retractor with the bolt.

Tighten

Tighten the seat belt retractor bolt to 30–45 N•m (22–33 lb-ft).

- b. Seat belt retractor bolt.

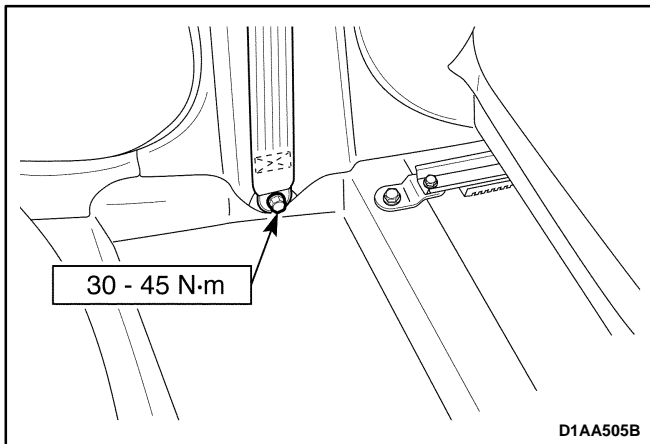

4. Install the bolt on the lower B-pillar.

- Install the bolt.

Tighten

Tighten the lower B-pillar bolt to 30–45 N•m (22–33 lb-ft).

- Install the spacers and the spring washer.
- Install the plastic protector on the seat belt anchor.

5. Relocate the seatback.

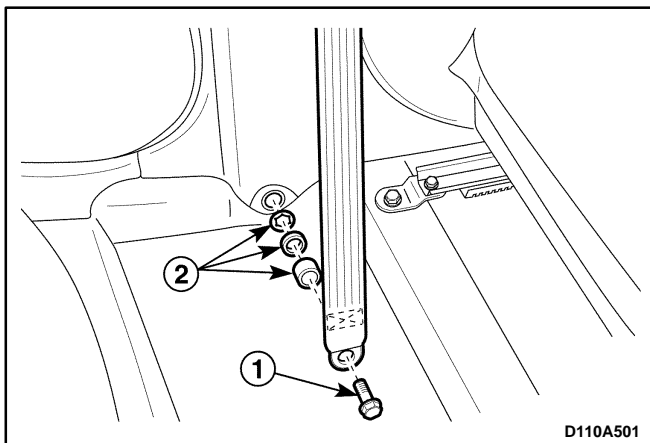

THREE-POINT PRETENSIONER FRONT SEAT BELT (W/EUROPE ONLY)

Removal Procedure

1. Slide the front seat forward and fold the seatback.
2. Remove the bolt on the lower B-pillar.

- Remove the bolt (1).
- Remove the spacer and the fiber washer (2).
- Remove the plastic protector on the seat belt anchor.

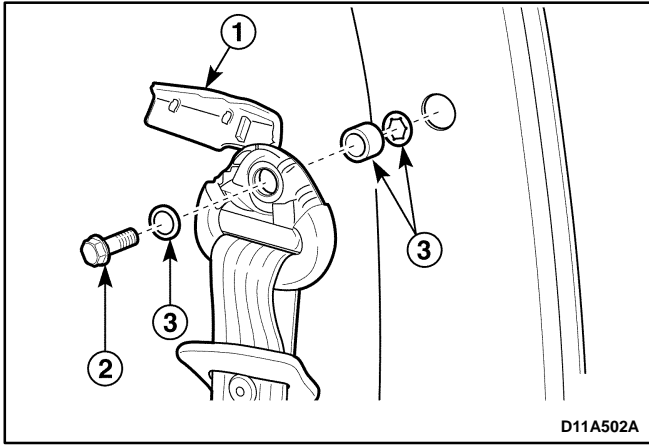

3. Remove the lower B-pillar trim panel. Refer to Section 9G, Interior Trim.
4. Remove the bolt on the upper B-pillar.
 - Using a flathead screwdriver, open the bolt cap (1).
 - Remove the bolt (2).
 - Remove the spacer and the fiber washer (3).

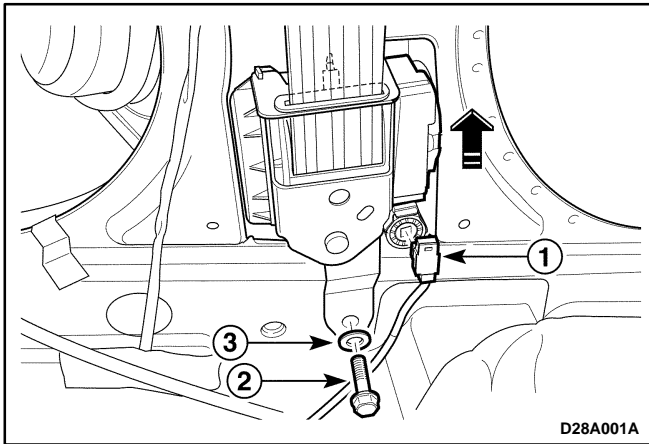

5. Remove the seat belt retractor bolts.
 - Remove the floor carpet to be seen the retractor.
 - Disconnect the pretensioner front seat belt connector (1).
 - Remove the lower retractor bolt (2).
 - Remove the fiber washer (3).
 - Remove the seat belt retractor.

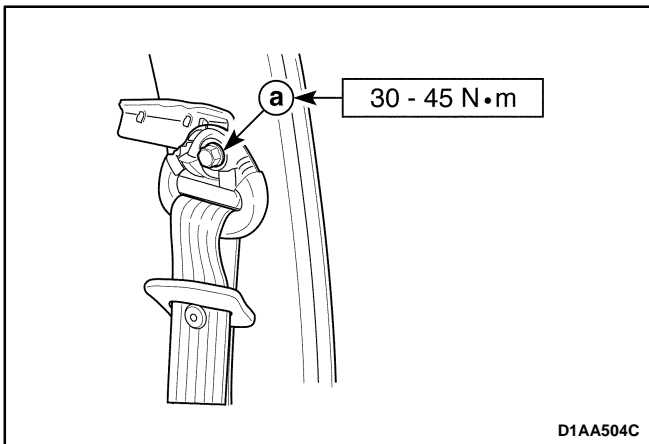

Installation Procedure

Notice: Dissimilar metals in direct contact with each other may corrode rapidly. Make sure to use the correct fasteners to prevent premature corrosion.

1. Install in the reverse order of removal.
2. Install the bolt on the upper B-pillar.

Tighten

Tighten the seat belt upper bolt to 30–45 N•m (22–33 lb-ft).

- a. Seat belt upper bolt.

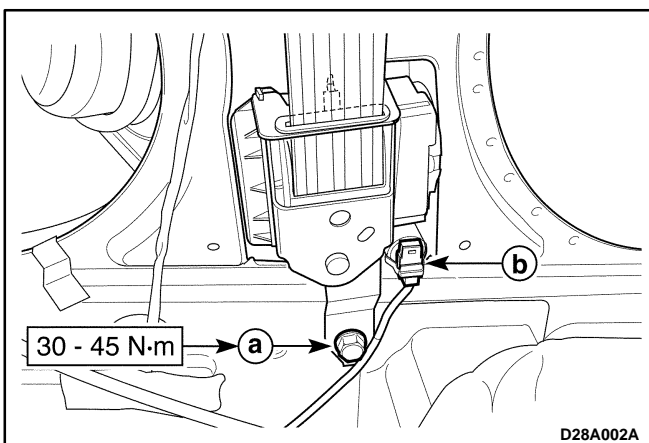

3. Install the seat belt retractor with the bolt.

Tighten

- Tighten the lower retractor bolt to 30–45 N•m (22–33 lb-ft).

- a. Lower retractor bolt.
- b. Connect the pretensioner front seat belt connector.

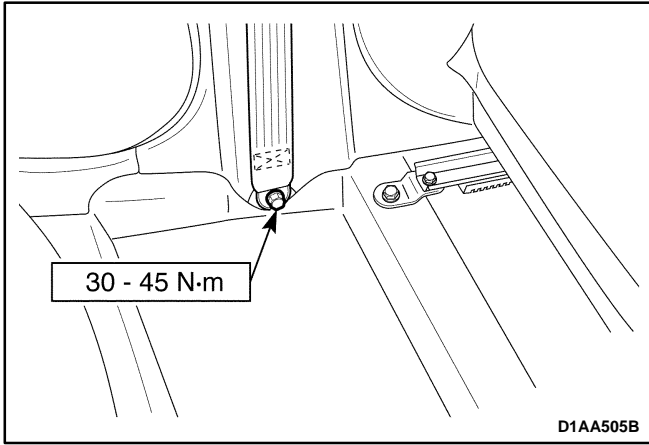

4. Install the bolt on the lower B-pillar.

- Install the bolt.

Tighten

Tighten the lower B-pillar bolt to 30–45 N•m (22–33 lb-ft).

- Install the spacers and the fiber washer.
- Install the plastic protector on the seat belt anchor.

5. Relocate the seatback.

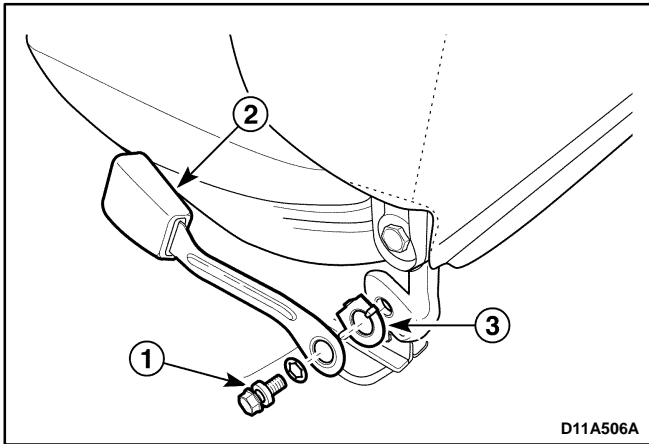

FRONT SEAT BELT BUCKLE

Removal Procedure

1. Remove the front seat belt buckle

- Remove the bolt (1).
- Remove the buckle (2).
- Remove the patch (3).
- Before removing the driver seat belt buckle, disconnect the reminder light connector.

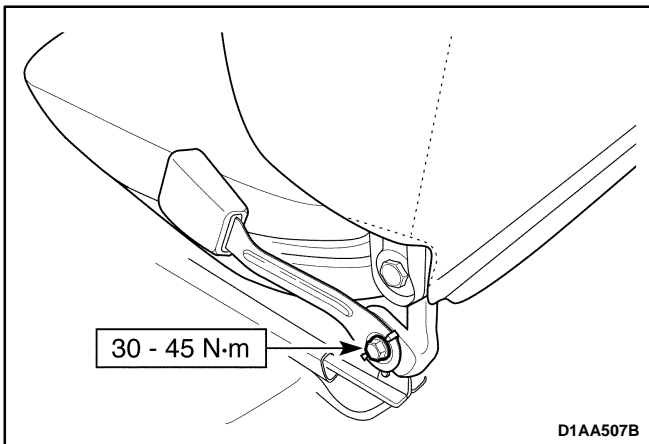

Installation Procedure

1. Install the front seat belt buckle.

- Connect the reminder light connector.
- Install the patch.
- Install the buckle.
- Install the bolt.

Tighten

Tighten the seat belt buckle bolt to 30–45 N•m (22–33 lb-ft).

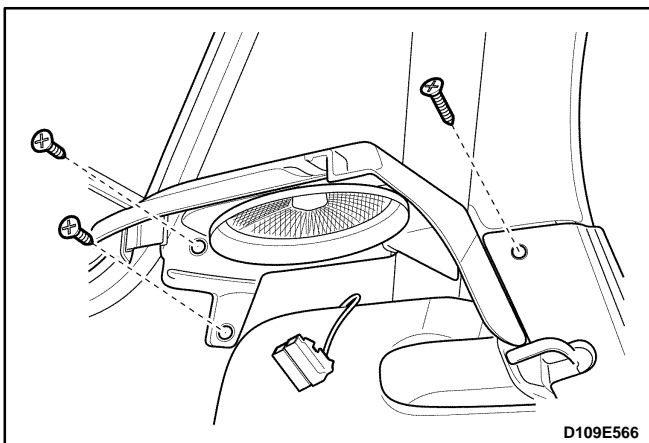

THREE-POINT ELR REAR OUTBOARD SEAT BELT

Removal Procedure

1. Remove the rear seat cushion and the rear seatback.

2. Pry off the rear interior trim panel. Refer to *Section 9G, Interior Trim*.

- Pry off the backshelf trim panel.
- Pry off the luggage compartment side load trim panel.

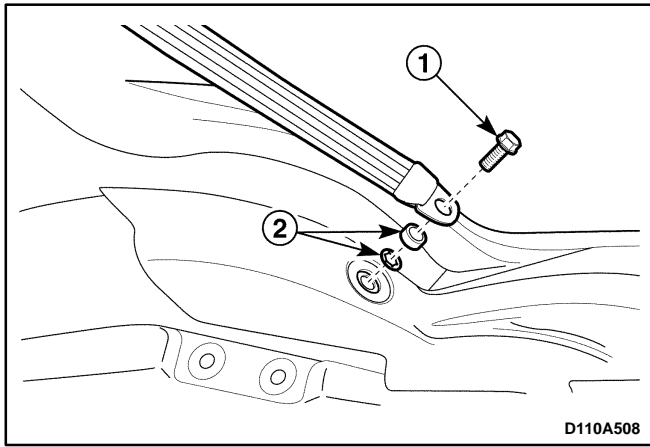

3. Remove the bolt on the floor.
 - Remove the bolt (1).
 - Remove the spacer and the fiber washer (2).
 - Remove the plastic protector on the seat belt anchor.

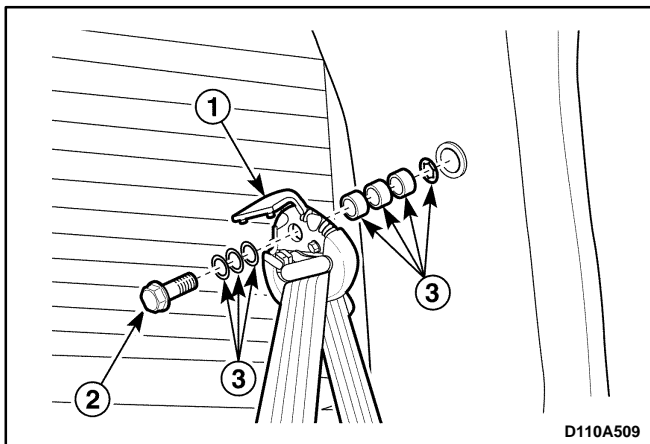

4. Pry off the luggage compartment trim panel. Refer to section 9G, *Interior Trim*.
5. Remove the bolt on the C-pillar trim panel (1).
 - Open the bolt cap using a flathead screw driver.
 - Remove the bolt (2).
 - Remove the plastic washers, the spacers and the fiber washer (3).

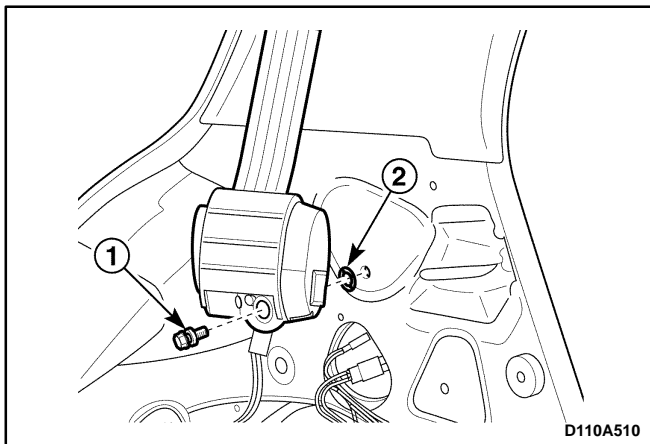

6. Remove the seat belt retractor bolt.
 - Remove the bolt (1).
 - Remove the fiber washer (2).
 - Remove the rear seat belt.

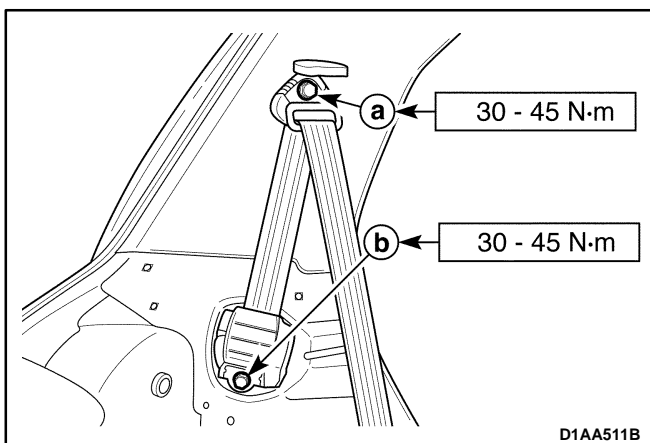

Installation Procedure

1. Install in the reverse order of removal.
2. Install the seat belt retractor bolt and the upper bolt.

Tighten

- Tighten the seat belt upper bolt to 30–45 N•m (22–33 lb-ft).
 - a. Seat belt upper bolt.
- Tighten the seat belt retractor bolt to 30–45 N•m (22–33 lb-ft).
 - b. Retractor bolt.

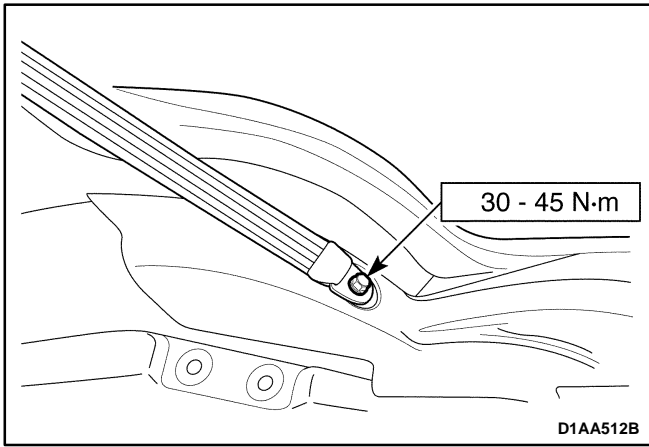

3. Install the bolt on the floor.

Tighten

Tighten the bolt on the floor to 30–45 N•m (22–33 lb-ft).

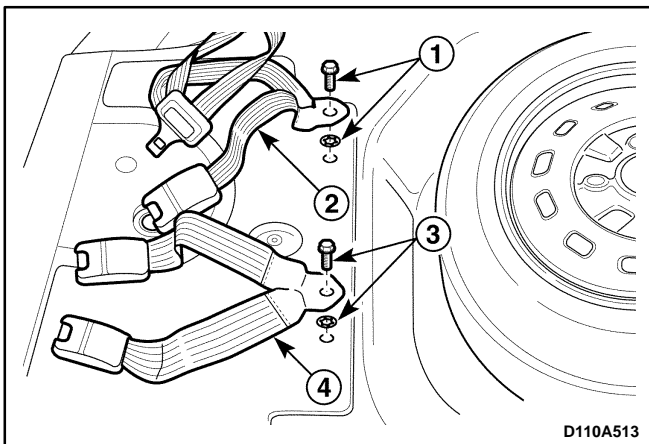

TWO-POINT LAB REAR CENTER SEAT BELT

Removal Procedure

1. Remove the rear seat cushion.
2. Remove the two-point rear seat belt and the buckle.
 - Remove the bolt and the fiber washer (1).
 - Remove the seat belt (two-point) and the buckle (three-point) (2).
 - Remove the bolt and the fiber washer (3).
 - Remove the buckle (two-point and three-point) (4).

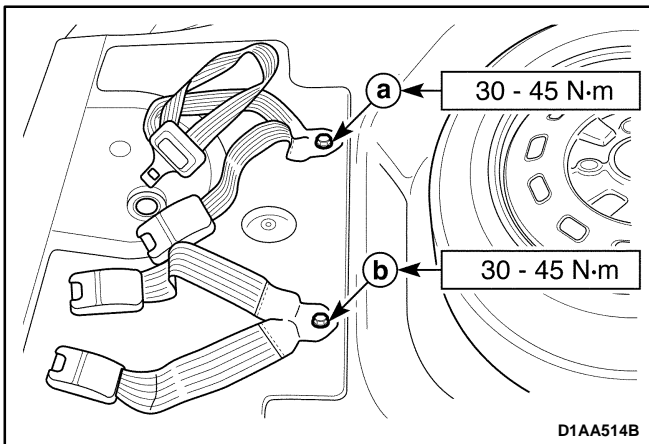

Installation Procedure

1. Install in the reverse order of removal.
2. Install the three-point rear seat belt buckle with the bolt.

Tighten

Tighten the three-point rear seat belt buckle bolt and the two-point rear seat belt bolt to 30–45 N•m (22–33 lb-ft).

- a. Two-point rear seat belt and three-point rear seat belt buckle bolt.
3. Install the two-point rear seat belt with the bolt.

Tighten

Tighten the two-point and three-point rear seat belt buckle bolt to 30–45 N•m (22–33 lb-ft).

- b. Two-point and three-point rear seat belt buckle bolt.

SPECIFICATIONS

FASTENER TIGHTENING SPECIFICATIONS

Application	N•m	Lb-Ft	Lb-In
Seat Belt Upper Bolt	30 – 45	22 – 33	–
Seat Belt Lower Bolt	30 – 45	22 – 33	–
Seat Belt Retractor Bolt	30 – 45	22 – 33	–
Seat Belt Buckle Bolt	30 – 45	22 – 33	–
Rear Seat Belt Buckle Bolt	30 – 45	22 – 33	–

SCHEMATIC AND ROUTING DIAGRAMS

DRIVER SEAT BELT WARNING

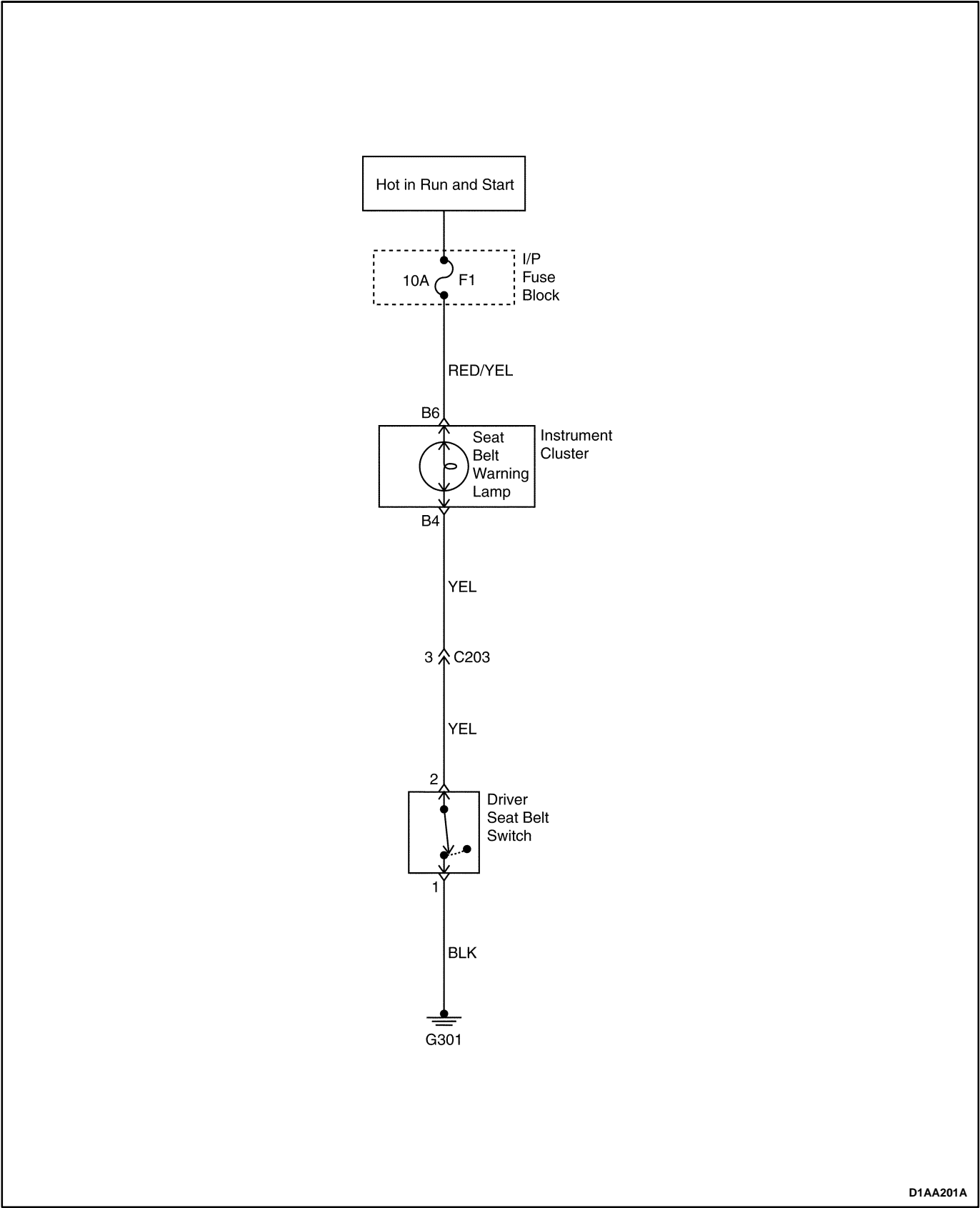

SECTION 8B

SUPPLEMENTAL INFLATABLE RESTRAINTS (SIR)

CAUTION: *Disconnect the negative battery cable before removing or installing any electrical unit or when a tool or equipment could easily come in contact with exposed electrical terminals. Disconnecting this cable will help prevent personal injury and damage to the vehicle. The ignition must also be in B unless otherwise noted.*

TABLE OF CONTENTS

Description and Operation	8B-3	DTC 10 Driver Pretensioner Circuit, Resistance Too Low	8B-32
Airbag Module	8B-3	DTC 11 Driver Pretensioner Circuit, Short to Ground	8B-34
Sensing and Diagnostic Module (SDM)	8B-3	DTC 12 Driver Pretensioner Circuit, Short to Battery Voltage	8B-36
SIR Warning Lamp	8B-3	DTC 13 Passenger Pretensioner Circuit, Resistance Too High	8B-38
Clock Spring	8B-4	DTC 14 Passenger Pretensioner Circuit, Resistance Too Low	8B-40
Wiring Harness/Connectors	8B-4	DTC 15 Passenger Pretensioner Circuit, Short to Ground	8B-42
SIR System	8B-4	DTC 16 Passenger Pretensioner Circuit, Short to Battery Voltage	8B-44
General Precautions	8B-5	DTC 18 Connection Between Driver Firing Circuit and Driver Pretensioner Circuit	8B-46
Airbag Deployment Condition	8B-5	DTC 19 Connection Between Driver Firing Circuit and Passenger Pretensioner Circuit	8B-48
Airbag Deployment Procedure	8B-6	DTC 20 Connection Between Passenger Firing Circuit and Driver Pretensioner Circuit	8B-50
Component Locator	8B-7	DTC 21 Connection Between Passenger Firing Circuit and Passenger Pretensioner Circuit	8B-52
SIR Component	8B-7	DTC 22 Connection Between Driver Pretensioner Circuit and Passenger Pretensioner Circuit	8B-54
Diagnostic Information and Procedures	8B-8	DTC 23 Ignition Input Circuit, Voltage Too High	8B-56
Bulb Check	8B-8	DTC 24 Ignition Input Circuit, Voltage Too Low	8B-58
Fault Indication	8B-8	DTC 25 Warning Lamp Failure	8B-60
Clearing Fault Codes	8B-8	DTC 31 SDM Internal Fault	8B-63
Microprocessor – Independent Lamp Activation	8B-8	DTC 32 SDM Crash Recorded	8B-63
System Check	8B-10	Diagnostic Illustration 1	8B-63
Fault Codes	8B-12	Diagnostic Illustration 2	8B-64
DTC 01 Driver Firing Circuit, Resistance Too High	8B-14	Diagnostic Illustration 3	8B-64
DTC 02 Driver Firing Circuit, Resistance Too Low	8B-16	Diagnostic Illustration 4	8B-64
DTC 03 Driver Firing Circuit, Short To Ground	8B-18	Diagnostic Illustration 5	8B-64
DTC 04 Driver Firing Circuit, Short To Battery Voltage	8B-20	Diagnostic Illustration 6	8B-65
DTC 05 Passenger Firing Circuit, Resistance Too High	8B-22	Diagnostic Illustration 7	8B-65
DTC 06 Passenger Firing Circuit, Resistance Too Low	8B-24		
DTC 07 Passenger Firing Circuit, Short To Ground	8B-26		
DTC 08 Passenger Firing Circuit, Short To Battery Voltage	8B-28		
DTC 09 Driver Pretensioner Circuit, Resistance Too High	8B-30		

8B-2 SUPPLEMENTAL INFLATABLE RESTRAINTS (SIR)

Diagnostic Illustration 8	8B-65	Driver Airbag Module	8B-69
Diagnostic Illustration 9	8B-65	Clock Spring	8B-70
Diagnostic Illustration 10	8B-66	Passenger Airbag Module	8B-71
Diagnostic Illustration 11	8B-66	Sensing and Diagnostic Module (SDM)	8B-72
Diagnostic Illustration 12	8B-66	Airbag Module Deployment (In Vehicle)	8B-74
Diagnostic Illustration 13	8B-66	Airbag Module Deployment (Outside of Vehicle)	8B-76
Diagnostic Illustration 14	8B-67	Deployed Airbag Module Disposal Procedure	8B-76
Diagnostic Illustration 15	8B-67	Specifications	8B-78
Diagnostic Illustration 16	8B-67	Fastener Tightening Specifications	8B-78
Diagnostic Illustration 17	8B-67	Special Tools and Equipment	8B-78
Diagnostic Illustration 18	8B-68	Special Tools Table	8B-78
Diagnostic Illustration 19	8B-68	Schematic and Routing Diagrams	8B-79
Diagnostic Illustration 20	8B-68	Supplemental Inflatable Restraints (SIR)	
Diagnostic Illustration 21	8B-68	Electrical Schematic	8B-79
Repair Instructions	8B-69		
On-Vehicle Service	8B-69		

DESCRIPTION AND OPERATION

(Left-Hand Drive Shown, Right-Hand Drive Similar)

AIRBAG MODULE

Driver Airbag Module

Caution: *Tampering with the driver side airbag module creates the risk of an injury from an unexpected deployment. Therefore, the driver side airbag module should never be disassembled.*

The driver airbag module is under the center pad on the steering wheel.

The driver airbag module contains an ignitor charge and a gas generator to inflate the folded airbag.

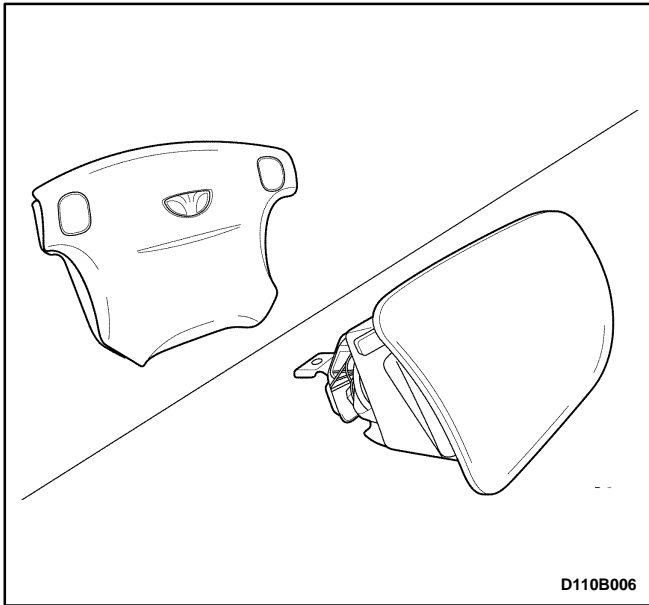

- Illuminates a warning lamp that alerts the driver to any faults.

- Allows the fault codes to be retrieved with a scan tool.

The SDM controls the deployment of the airbag system through the use of the

- Arming sensor.
- Capacitor.
- Crash sensor, or accelerometer.

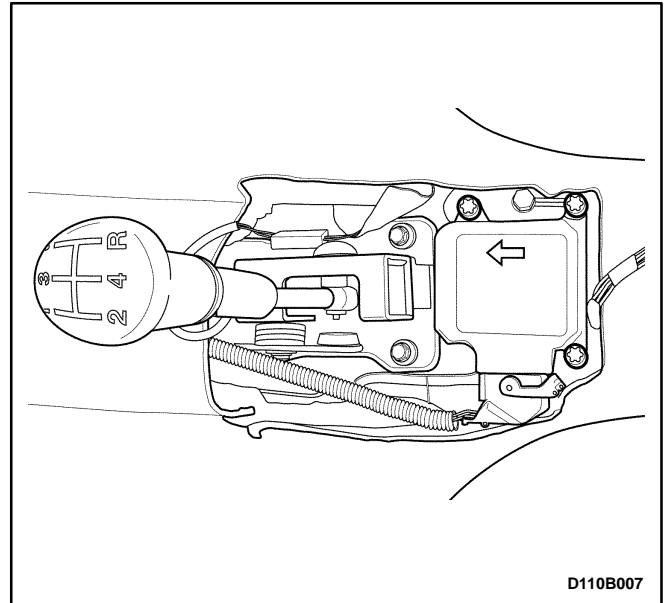

Passenger Airbag Module

Caution: *Tampering with the passenger side airbag module creates the risk of an injury from an unexpected deployment. Therefore, the passenger side airbag module should never be disassembled.*

The passenger airbag module is on the passenger side of the instrument panel.

The passenger airbag module contains an ignitor charge and a gas generator to inflate the folded airbag.

SENSING AND DIAGNOSTIC MODULE (SDM)

The SDM

- Has no user-serviceable parts.
- Is under the front console assembly.
- Continuously monitors the system components.
- Records any faults which are discovered.

Arming Sensor

The arming sensor is safety device made up of a dual-contact, electro-mechanical switch that:

- Acts independently of the electronic components.
- Keeps the firing circuits for the airbags unarmed under normal driving conditions.
- Allows the airbags to deploy under the required conditions.

Capacitor

The capacitor provides reserve power.

Crash Sensor

The crash sensor, or accelerometer, electronically represents the acceleration or deceleration of the vehicle during a frontal impact. In this electronic representation, the electrical signal is proportional to the acceleration or deceleration of the vehicle.

SIR WARNING LAMP

The supplemental inflatable restraints (SIR) system includes a self-diagnostic function.

8B-4 SUPPLEMENTAL INFLATABLE RESTRAINTS (SIR)

If there is a failure of the sensing and diagnostic module or the external circuits, the SIR warning lamp in the instrument cluster turns ON.

As a system check, the SIR warning lamp also turns ON when the ignition is first switched to the ON position.

Correct Functioning

The system is working properly if:

- The SIR warning lamp turns OFF after approximately four seconds.

Faulty Functioning

The system is not working properly, meaning one of the SIR components or the wiring connector is faulty, if:

- The SIR warning lamp fails to turn ON when the ignition is first switched ON.
- The SIR warning lamp remains ON.



CLOCK SPRING

The clock spring:

- Is on the steering column.
- Contains a coil that is the electrical contact between the steering column wiring harness and the driver side airbag module.
- Is part of the circuit for the horn.

Notice: Turning the steering wheel more than three and one-quarter turns may damage the clock spring.

Turning the steering wheel:

- In one direction tightens the coil.
- In the opposite direction loosens the coil.
- More than three and one-quarter turns may damage the clock spring.

Caution: *Disassembling the clock spring can cause injury and vehicle damage.*

The clock spring should never be disassembled.

The clock spring must be replaced if the airbags have been deployed.

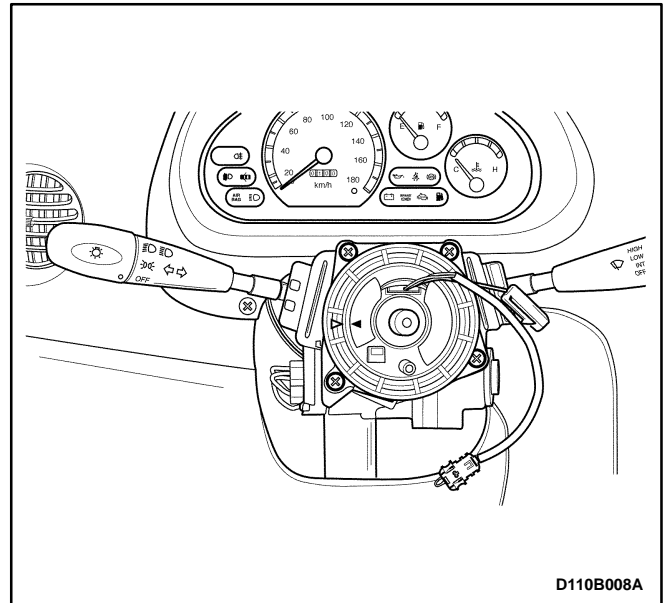

WIRING HARNESS/CONNECTORS

The connector for the sensing and diagnostic module (SDM) has a built-in shorting bar that will turn ON the warning lamp if there is a poor connection at the SDM.

As an anti-deployment mechanism, additional shorting bars are in the

- Connector for the clock spring at the lower steering column.
- Passenger airbag module connector.
- SDM connector.

When these connectors are separated, the shorting bars will short circuit any current which is applied, preventing the current from reaching the airbag modules.

SIR SYSTEM

The supplemental inflatable restraints (SIR) system is a safety device used in conjunction with the seat belts.

The airbag does not replace the function of the seat belt. The driver and the passengers must always fasten their seat belts and adjust them for a proper fit.

The SIR is designed to protect the driver and the front seat passenger in the event of a significant frontal impact to the vehicle. The airbags deploy if the force is applied from a direction within 30 degrees of the vehicle's centerline and above 25 km/h (15 mph) speed.

The SIR consists of a

- Driver airbag module.
- Passenger airbag module.

- Sensing and diagnostic module.
- Steering column clock spring.
- Wiring harness.
- SIR malfunction warning lamp.

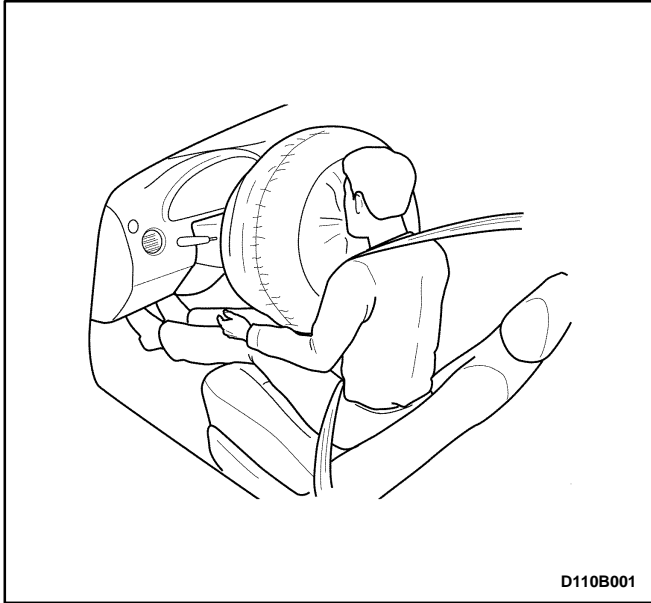

GENERAL PRECAUTIONS

The supplemental inflatable restraints (SIR) warning lamp must illuminate when the ignition is switched ON, and then turn OFF after approximately 4 seconds.

There is a fault in the airbag system if

- The warning lamp does not turn OFF.
- The warning lamp illuminates while the vehicle is in operation.

If the warning lamp indicates there is a fault in the airbag system, assume that the SIR system may not be functional.

Caution: *Failure to follow all service procedures in the correct sequence can cause the airbag system to deploy unexpectedly and possibly cause a serious injury.*

Only trained personnel at franchised Daewoo dealers and authorized Daewoo service dealerships may service the airbag system.

Never attempt to disassemble, repair, or reuse the

- Airbag modules.
- Clock spring.
- Sensing and diagnostic module.
- Wiring harness.

When making SIR repairs,

- Inspect any SIR part before it is installed.
- Use only new parts.
- Do not install used SIR parts from other vehicles.
- Do not install any part that has been dropped or that has dents, cracks, or other defects.

AIRBAG DEPLOYMENT CONDITION

Airbag is designed to deploy under 30° left/right angle barrier and above 25 km/h (15 mph) speed.

Concrete Barrier Deployment Condition

In case of the 0° frontal concrete barrier, airbag may deploy above 25 km/h (15 mph) speed.

AIRBAG DEPLOYMENT PROCEDURE

1. Non-Deployment condition

- a. Initiator
- b. Piston
- c. Safety disc
- d. Compressed Ar gas

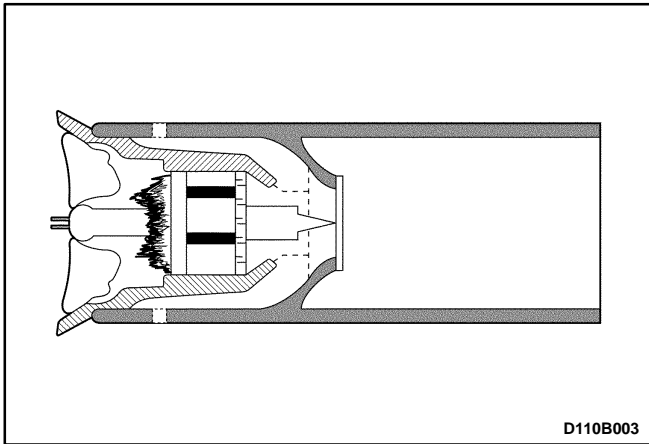
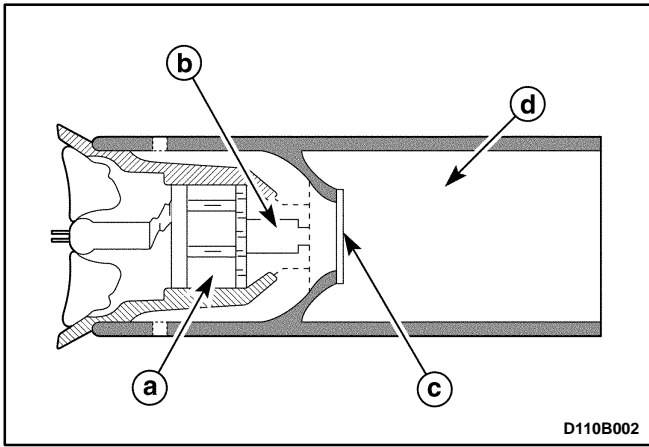

- 2. When crashing, firing current flows from the SDM to the initiator.
- 3. Initiator is burning and the inside pressure is increasing and the piston hits the safety disc.

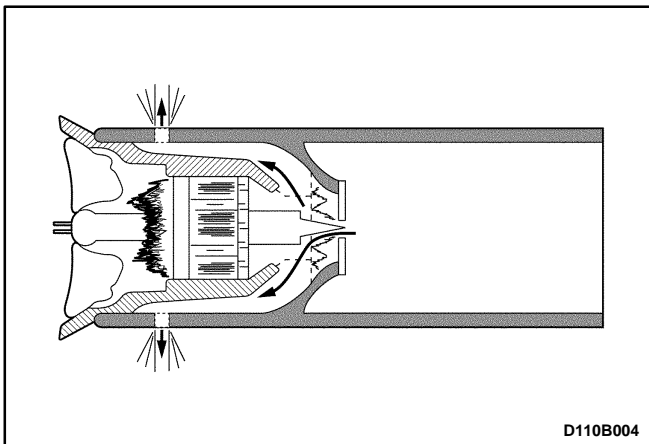

- 4. Safety disc is broken and the compressed Ar gas is spouted out.

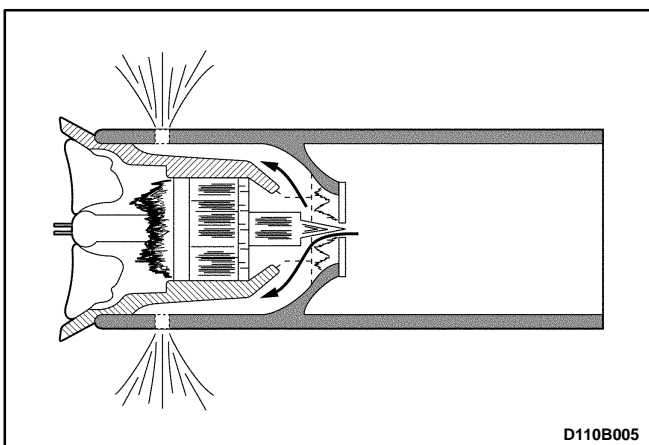

- 5. Compressed Ar gas and the burned initiator are carried forward. And the airbag is deployed.

COMPONENT LOCATOR

SIR COMPONENT

(Left-Hand Drive Shown, Right-Hand Drive Similar)

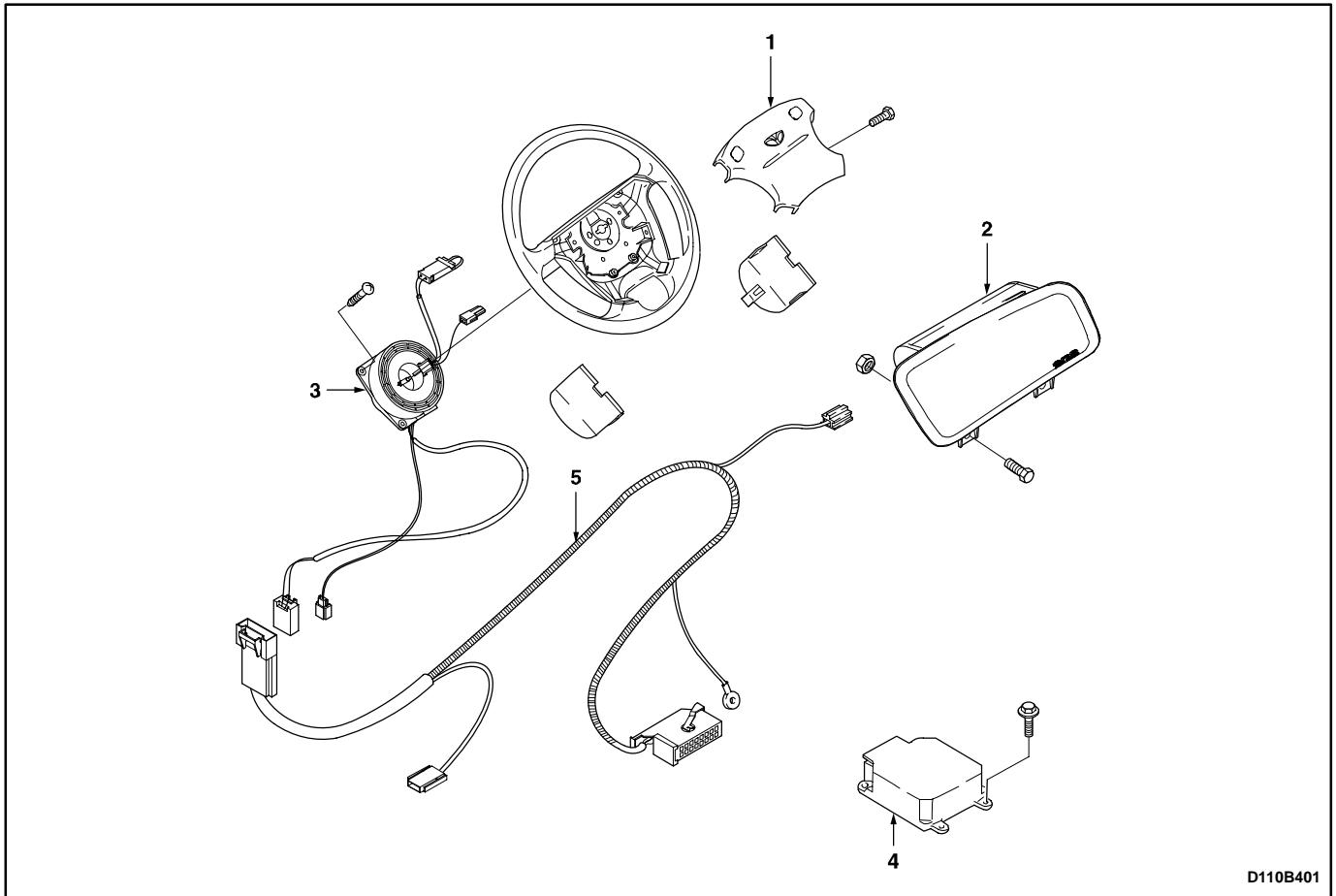

D110B401

- 1. Driver Airbag Module
- 2. Passenger Airbag Module
- 3. Clock Spring

- 4. Sensing and Diagnostic Module (SDM)
- 5. Wiring Harness

DIAGNOSTIC INFORMATION AND PROCEDURES



BULB CHECK

As soon as the operating voltage is applied to the sensing and diagnostic module (SDM) ignition input, the SDM activates the warning lamp for a bulb check.

The SDM turns the lamp ON for 4 seconds, and then the SDM turns the lamp OFF.

During the bulb check, the SDM is not ready to detect a crash or deploy the supplemental inflatable restraints.

FAULT INDICATION

The sensing and diagnostic module records the system's faults in two categories:

- Current faults and the fault code appears "Axx" on the scan tool display.
- Historic faults, which are those that were detected in the past, but are no longer active. And the fault code appears "Sxx" on the scan tool display.

The warning lamp:

- Indicates a fault as soon as it occurs.
- Stays ON, even if a fault is no longer active.

A scan tool connected to the data link connector (DLC):

- Reveals the fault codes.
- Receives serial data transmission through the terminal J (13) of the DLC.
- Receives ground through the terminal A (4) of the DLC.

CLEARING FAULT CODES

When the sensing and diagnostic module (SDM) receives the CODE ERASE command from the scan tool, the SDM:

- Clears the entire fault memory.
- Turns OFF the warning lamp.
- Resets for fault detection.

External Fault

Service personnel can reset the SDM and turn OFF the warning lamp if the fault is an external fault.

Internal Fault

An internal fault of the SDM or a CRASH RECORDED fault code cannot be reset.

In the case of an internal fault of the SDM or a CRASH RECORDED fault code, the SDM must be replaced.

Voltage-Low Fault

The SDM will turn OFF the VOLTAGE LOW fault as soon as the voltage recovers.

MICROPROCESSOR – INDEPENDENT LAMP ACTIVATION

If the sensing and diagnostic module (SDM) electrical connector is not properly attached, the SDM cannot function and cannot control the warning lamp.

If this fault is present, the warning lamp will operate independently from the SDM through the use of shorting bars that are built into the SDM connector.

BLANK

SYSTEM CHECK

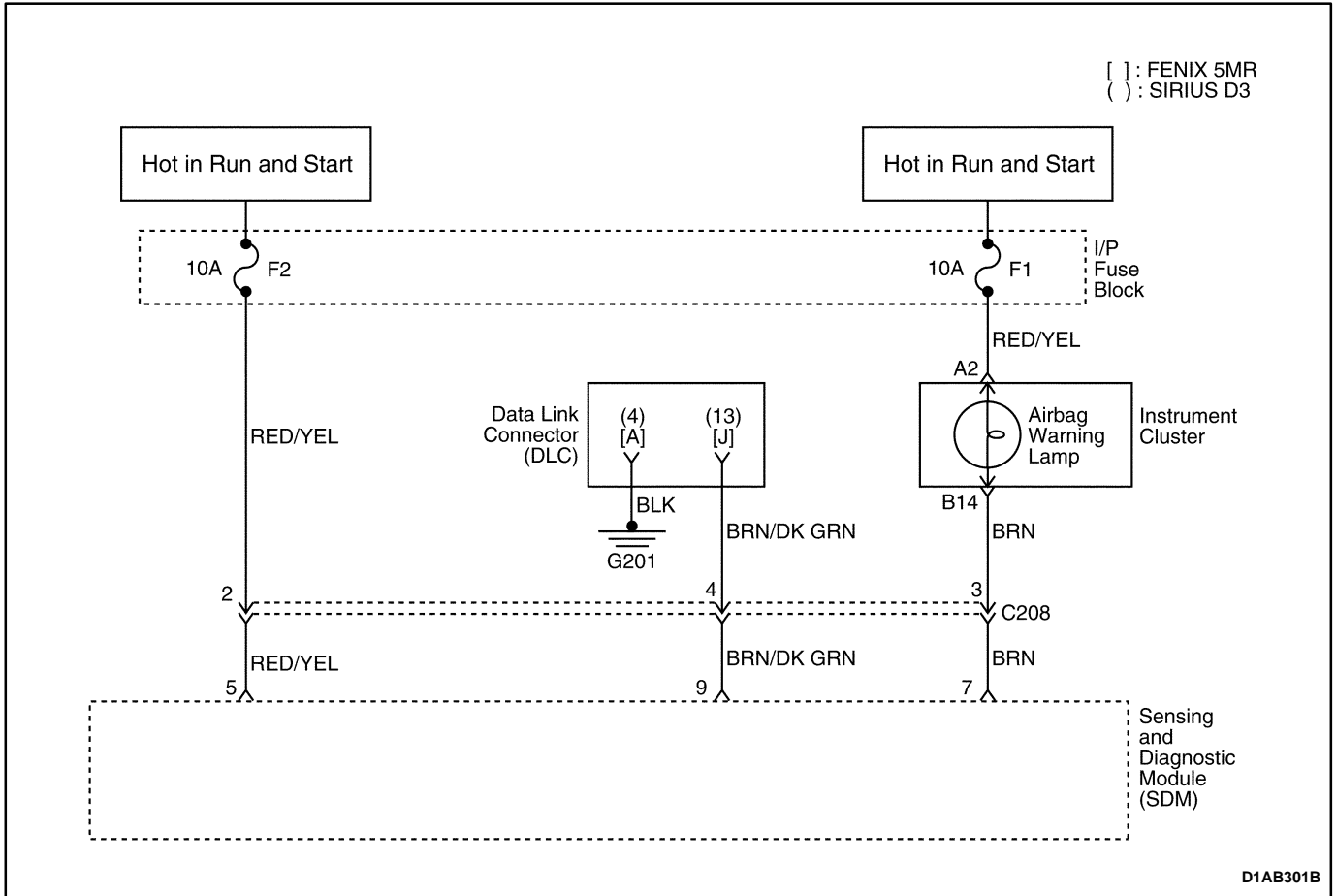

Caution: Use only the scan tool to check the airbag modules and the sensing and diagnostic module (SDM). Never measure the resistance of an airbag module with an ohmmeter. An ohmmeter’s battery can deploy the airbag and cause injury.

Caution: Before testing, disconnect the negative battery cable. Wait 1 minute for the SDM capacitor to discharge. The capacitor supplies reserve power to deploy the airbags, even if the battery is disconnected. Unintentional deployment of the airbags can cause injury.

Caution: Do not attempt to repair the supplemental inflatable restraints (SIR) wiring harness. An SIR repair can create a high-resistance connection which can keep the airbags from deploying when needed, resulting in injury.

Circuit Description

When the ignition switch is turned ON, the SDM is able to send serial data from the terminal 9 of the SDM to the terminal J (13) of the assembly line diagnostic link.

Diagnostic System Check

Step	Action	Value(s)	Yes	No
1	1. Turn the ignition ON. 2. Check the warning lamp. Does the warning lamp turn off after 4 seconds?	–	System OK	Go to Step 2
2	1. Connect the scan tool cable to the DLC. 2. Connect the scan tool power cable to the cigar lighter socket. 3. Select the airbag main menu on the scan tool. 4. Select “Fail Code View & Clear “ from the displayed menu of the diagnostic test codes (DTC). Are there any active fault codes?	–	Go to the DTC table for the fault indicated	Go to Step 3

Diagnostic System Check (Cont'd)

Step	Action	Value(s)	Yes	No
3	1. Check fuse F2. Is the fuse F2 blown?	–	Go to Step 4	Go to Step 5
4	1. Replace fuse F2. Is the repair complete?	–	System OK	–
5	1. Disconnect the electrical connector C208. 2. Check for a short to ground between fuse F2 and terminal 2 of connector C208. Is wiring harness shorted to ground?	–	Go to Step 6	Go to Step 7
6	Repair a short to ground between fuse F2 and terminal 2 of connector C208. Is the repair complete?	–	System OK	–
7	1. Disconnect the SDM electrical connector. 2. Check for a short to ground between terminal 2 and terminal 5 of SDM connector. Is wiring harness shorted to ground?	–	Go to Step 15	Go to Step 8
8	Use an ohmmeter to check for continuity between terminal A (4) of the DLC and ground G201. Does the ohmmeter show the specified value?	≈0 Ω	Go to Step 9	Go to Step 10
9	Repair the open DLC ground circuit. Is the repair complete?	–	System OK	–
10	1. Turn the ignition ON. 2. Check the voltage at the cigar lighter positive terminal. Does the voltmeter show the specified value?	11–14V	Go to Step 12	Go to Step 11
11	Repair the power supply for the cigar lighter socket. Is the repair complete?	–	System OK	–
12	Check for a short to ground or open circuit between terminal J (13) of the DLC and terminal 4 of connector 208. Is wiring harness shorted to ground or open?	–	Go to Step 13	Go to Step 14
13	Repair a short to ground or open circuit between terminal J (13) of the DLC and terminal 4 of connector C208. Is the repair complete?	–	System OK	–
14	Check for a short to ground or open between terminal 4 of connector C208 and terminal 9 of the SDM connector. Is wiring harness shorted to ground or open?	–	Go to Step 15	Go to Step 16
15	Replace the SDM wiring harness. Is the repair complete?	–	System OK	–
16	Replace the SDM. Is the repair complete?	–	System OK	–

FAULT CODES

Fault Codes	Fault Contents
01	Driver Firing Circuit, Resistance Too High
02	Driver Firing Circuit, Resistance Too Low
03	Driver Firing Circuit, Short to Ground
04	Driver Firing Circuit, Short to Battery Ground
05	Passenger Firing Circuit, Resistance Too High
06	Passenger Firing Circuit, Resistance Too Low
07	Passenger Firing Circuit, Short to Ground
08	Passenger Firing Circuit, Short to Battery Voltage
09	Driver Pretensioner Circuit, Resistance Too High
10	Driver Pretensioner Circuit, Resistance Too Low
11	Driver Pretensioner Circuit, Short to Ground
12	Driver Pretensioner Circuit, Short to Battery Voltage
13	Passenger Pretensioner Circuit, Resistance Too High
14	Passenger Pretensioner Circuit, Resistance Too Low
15	Passenger Pretensioner Circuit, Short to Ground
16	Passenger Pretensioner Circuit, Short to Battery Voltage
17	Connection Between Driver Firing Circuit and Passenger Firing Circuit
18	Connection Between Driver Firing Circuit and Driver Pretensioner Circuit
19	Connection Between Driver Firing Circuit and Passenger Pretensioner Circuit
20	Connection Between Passenger Firing Circuit and Driver Pretensioner Circuit
21	Connection Between Passenger Firing Circuit and Passenger Pretensioner Circuit
22	Connection Between Driver Pretensioner Circuit and Passenger Pretensioner Circuit
23	Ignition Input Circuit, Voltage Too High
24	Ignition Input Circuit, Voltage Too Low
25	Warning Lamp Failure
31	SDM Internal Fault
32	SDM Crash Recorded

BLANK

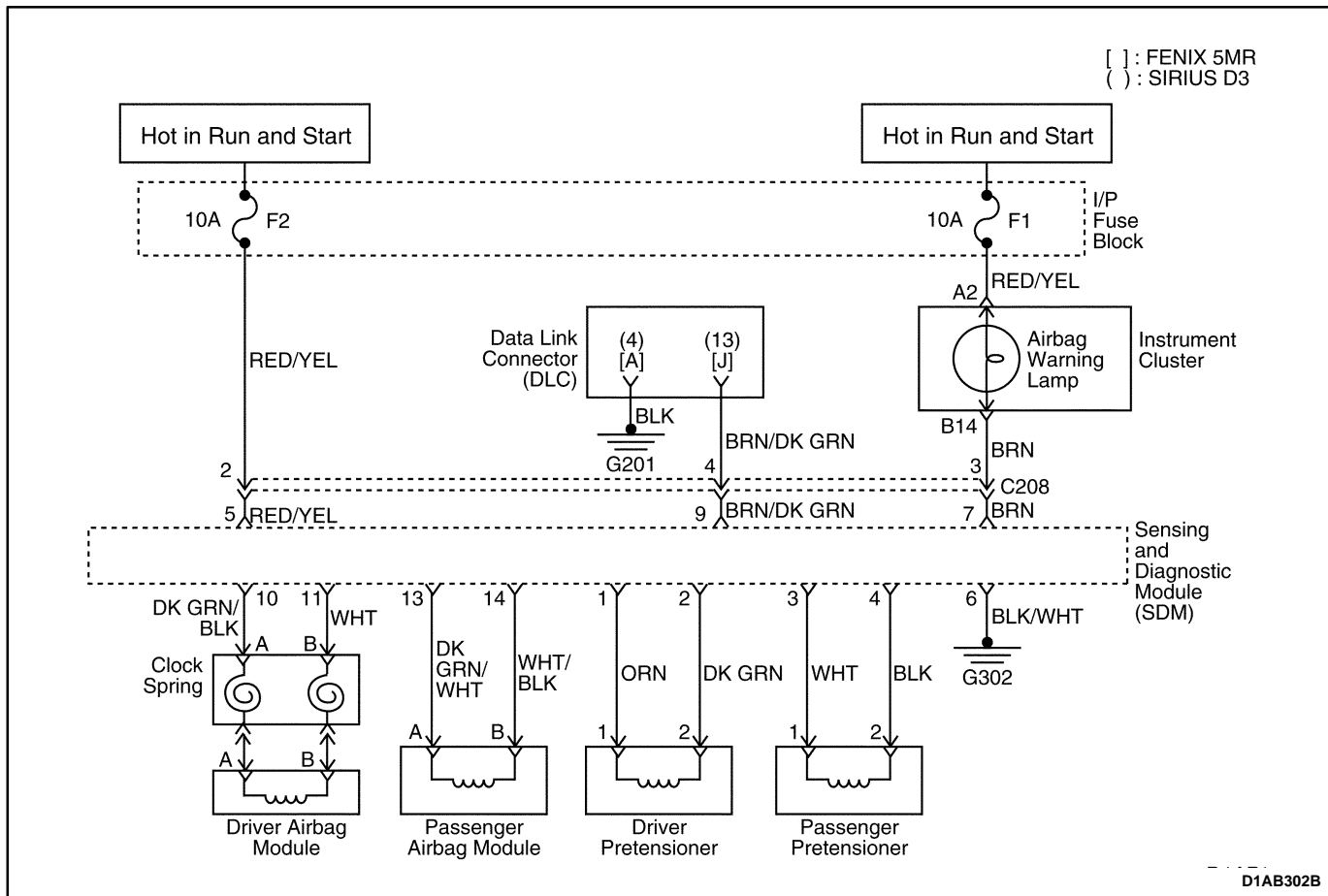

DIAGNOSTIC TROUBLE CODE (DTC) 01 DRIVER FIRING CIRCUIT, RESISTANCE TOO HIGH

Open Circuit

Circuit Description

When the ignition switch is turned ON, the sensing and diagnostic module (SDM) will perform tests to diagnose any malfunctions within itself.

After passing these tests, the SDM will check the driver airbag module firing circuit. The SDM allows a very small amount of current to flow through the driver airbag module firing circuit. The SDM monitors the circuit resistance during this check.

DTC 01 Will Set When

- The combined resistance of the driver airbag module, the harness wiring, and the connector contacts is above a specified value, as with an open circuit.

Test Description

Caution: Before testing, disconnect the negative battery cable. Wait 1 minute for the SDM capacitor to discharge. The capacitor supplies reserve power to deploy the airbags, even if the battery is disconnected. Unintentional deployment of the airbags can cause injury.

Caution: Never measure the resistance of an airbag module with an ohmmeter. An ohmmeter's battery can deploy the airbag and cause injury.

Caution: Do not attempt to repair the supplemental inflatable restraints (SIR) wiring harness. A repair can create a high-resistance connection which can keep the airbags from deploying when needed, resulting in injury.

DTC 01 – Driver Firing Circuit, Resistance Too High

Step	Action	Value(s)	Yes	No
1	Examine the wiring and the connector at the driver airbag module. Is the connector disconnected?	–	Go to <i>Step 2</i>	Go to <i>Step 3</i>
2	1. Reconnect the driver airbag module connector. 2. Reinstall the driver airbag module in the steering wheel. 3. Reconnect the negative battery terminal. Is the repair complete?	–	Go to <i>Diagnostic System Check</i>	–
3	1. Remove the driver airbag module. 2. Place the driver airbag module in a secure position with the decorative surface facing upward. 3. Disconnect the electrical connector at the SDM. <ul style="list-style-type: none"> The shorting bar at the disconnected SDM connector will create a complete circuit between the wires from the driver airbag module. 4. Connect an ohmmeter to the terminals of the wiring harness connector for the driver airbag module. <ul style="list-style-type: none"> Refer to “Diagnostic Illustration 3” in this section. Does the ohmmeter indicate the specified value?	$\approx 0 \Omega$	Go to <i>Step 4</i>	Go to <i>Step 6</i>
4	1. Replace the SDM. 2. Reconnect the negative battery cable. 3. Set the scan tool for CODE ERASE. 4. Do the diagnostic system check. Does the code 01 still show as a current fault?	–	Go to <i>Step 5</i>	System OK
5	1. Replace the driver airbag module. 2. Reconnect the negative battery terminal. Is the repair complete?	–	Go to <i>Diagnostic System Check</i>	–
6	1. Disconnect the clock spring wiring harness connector at the lower steering column. <ul style="list-style-type: none"> The shorting bar at the disconnected SDM connector will create a complete circuit between the wires from the clock spring. 2. Connect an ohmmeter to the terminals at the SDM side of the clock spring connector. <ul style="list-style-type: none"> Refer to “Diagnostic Illustration 4” in this section. Does the ohmmeter show the specified value?	$\approx 0 \Omega$	Go to <i>Step 7</i>	Go to <i>Step 8</i>
7	1. Replace the clock spring. 2. Reconnect the negative battery terminal. Is the repair complete?	–	Go to <i>Diagnostic System Check</i>	–
8	1. Replace the SIR wiring harness. 2. Reconnect the negative battery cable. Is the repair complete?	–	Go to <i>Diagnostic System Check</i>	–

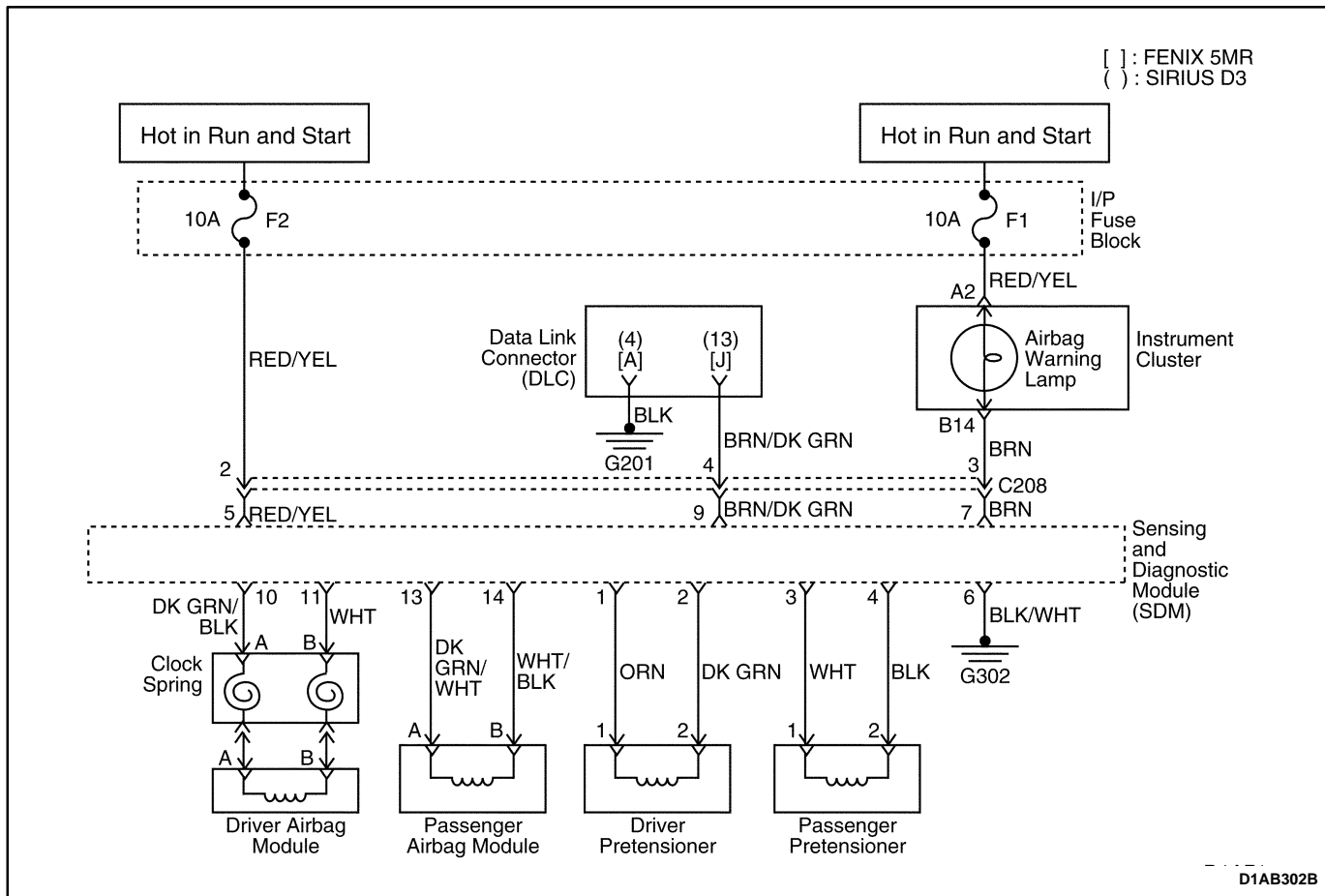

DIAGNOSTIC TROUBLE CODE (DTC) 02 DRIVER FIRING CIRCUIT, RESISTANCE TOO LOW

Short Circuit

Circuit Description

When the ignition switch is turned ON, the sensing and diagnostic module (SDM) will perform tests to diagnose any malfunctions within itself.

After passing these tests, the SDM will check the driver airbag module firing circuit. The SDM allows a very small amount of current to flow through the airbag module firing circuit. The SDM monitors the circuit resistance during this check.

DTC 02 Will Set When

- The combined resistance of the driver airbag module, the harness wiring, and the connector contacts is below a specified value, as with a short circuit between the wires to the driver airbag module.

Test Description

Caution: Before testing, disconnect the negative battery cable. Wait 1 minute for the SDM capacitor to discharge. The capacitor supplies reserve power to deploy the airbags, even if the battery is disconnected. Unintentional deployment of the airbags can cause injury.

Caution: Never measure the resistance of an airbag module with an ohmmeter. An ohmmeter's battery can deploy the airbag and cause injury.

DTC 02 – Driver Firing Circuit, Resistance Too Low

Step	Action	Value(s)	Yes	No
1	1. Remove the driver airbag module. 2. Store the driver airbag module with the decorative side facing upward. 3. Connect an ohmmeter to the terminals of the wiring harness connector for the driver airbag module. • Refer to “Diagnostic Illustration 3” in this section. Does the ohmmeter show the specified value?	∞	Go to <i>Step 2</i>	Go to <i>Step 4</i>
2	1. Replace the SDM. 2. Reconnect the negative battery cable. 3. Set the scan tool to CODE ERASE. 4. Do the diagnostic system check. Does the code 02 still show as a current fault?	–	Go to <i>Step 3</i>	System OK
3	1. Replace the driver airbag module. 2. Reconnect the negative battery cable. Is the repair complete?	–	Go to <i>Diagnostic System Check</i>	–
4	1. Disconnect the clock spring wiring harness connector at the lower steering column. 2. Connect an ohmmeter to the terminals at the SDM side of the clock spring connector. • Refer to “Diagnostic Illustration 4” in this section. Does the ohmmeter show the specified value?	∞	Go to <i>Step 5</i>	Go to <i>Step 6</i>
5	1. Replace the clock spring. 2. Reconnect the negative battery cable. Is the repair complete?	–	Go to <i>Diagnostic System Check</i>	–
6	1. Replace the supplemental inflatable restraints (SIR) wiring harness. 2. Reconnect the negative battery cable. Is the repair complete?	–	Go to <i>Diagnostic System Check</i>	–

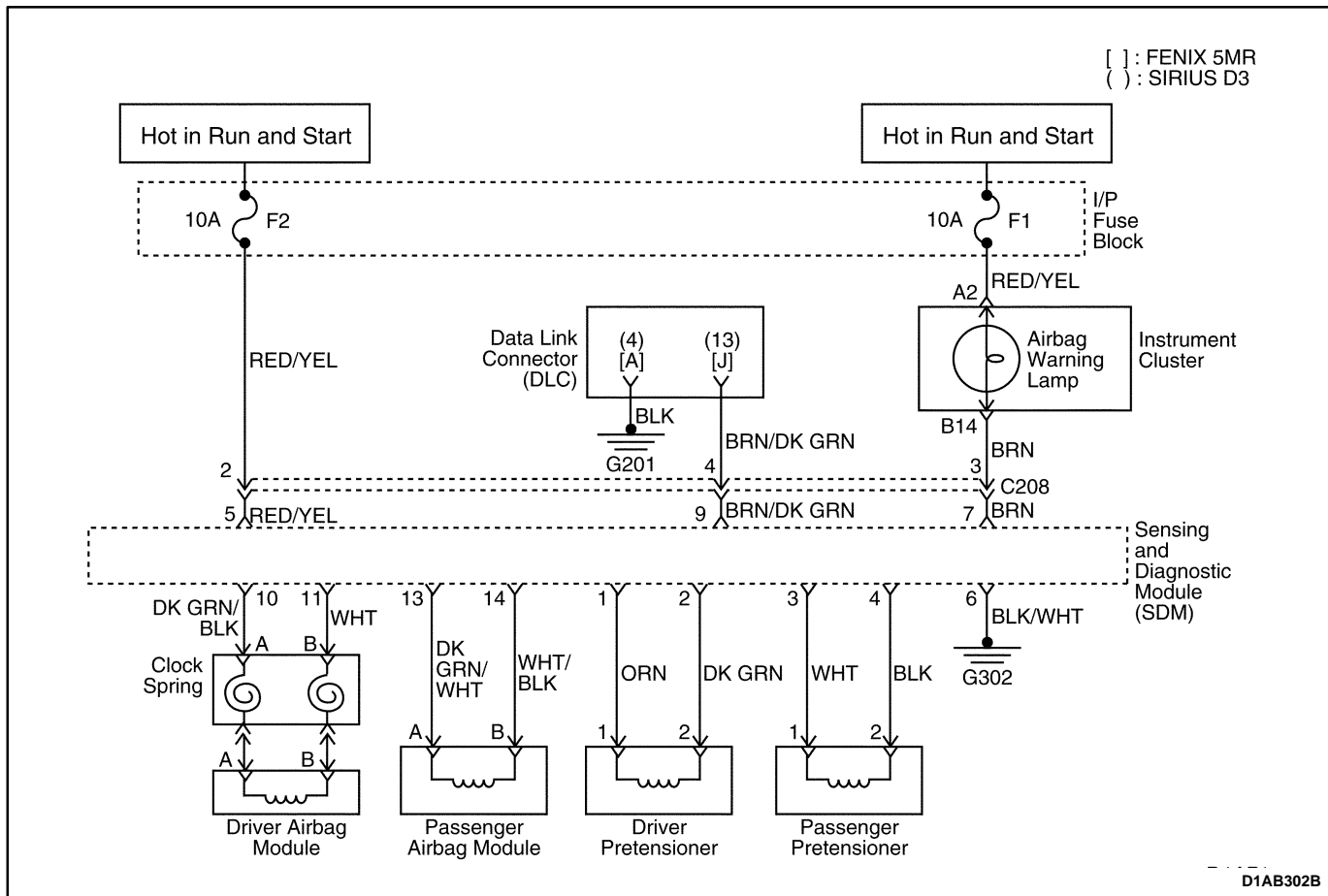

DIAGNOSTIC TROUBLE CODE (DTC) 03 DRIVER FIRING CIRCUIT, SHORT TO GROUND

Circuit Description

When the ignition switch is turned ON, the sensing and diagnostic module (SDM) will perform tests to diagnose any malfunctions within itself.

After passing these tests, the SDM will check the driver airbag module firing circuit. The SDM allows a very small amount of current to flow through the driver airbag module firing circuit. The SDM monitors the voltage during this check.

DTC 03 Will Set When

- The firing circuit is shorted to ground.

Test Description

Caution: Before testing, disconnect the negative battery cable. Wait 1 minute for the SDM capacitor to discharge. The capacitor supplies reserve power to deploy the airbags, even if the battery is disconnected. Unintentional deployment of the airbags can cause injury.

DTC 03 – Driver Firing Circuit, Short To Ground

Step	Action	Value(s)	Yes	No
1	Visually inspect the supplemental inflatable restraints (SIR) wiring harness for damage. Is there any visible damage to the SIR harness?	–	Go to <i>Step 2</i>	Go to <i>Step 3</i>
2	1. Replace the SIR wiring harness. 2. Reconnect the negative battery cable. Is the repair complete?	–	Go to <i>Diagnostic System Check</i>	–
3	1. Remove the driver airbag module. 2. Place the driver airbag module in a secure position with the decorative surface facing upward. 3. Disconnect the electrical connector at the SDM. <ul style="list-style-type: none"> The shorting bar at the disconnected SDM connector will create a complete circuit between the wires from the driver airbag module. 4. Use an ohmmeter to check the continuity between ground and one of the terminals on the wiring harness connector for the driver airbag module. <ul style="list-style-type: none"> Refer to “Diagnostic Illustration 5” in this section. Is the resistance less than the specified value?	∞	Go to <i>Step 6</i>	Go to <i>Step 4</i>
4	1. Replace the SDM. 2. Reconnect the negative battery cable. 3. Set the scan tool for CODE ERASE. 4. Do the diagnostic system check. <ul style="list-style-type: none"> Refer to the “Diagnostic System Check” in this section. Does the code 03 still show as a current fault?	–	Go to <i>Step 5</i>	System OK
5	1. Replace the driver airbag module. 2. Reconnect the negative battery cable. Is the repair complete?	–	Go to <i>Diagnostic System Check</i>	–
6	1. Disconnect the clock spring wiring harness connector at the lower steering column. <ul style="list-style-type: none"> The shorting bar at the disconnected SDM connector will create a complete circuit between the wires from the clock spring. 2. Using an ohmmeter, check for continuity between ground and one of the terminals on the SDM side of the clock spring connector. Is the resistance less than the specified value?	∞	Go to <i>Step 2</i>	Go to <i>Step 7</i>
7	1. Replace the clock spring. 2. Reconnect the negative battery terminal. Is the repair complete?	–	Go to <i>Diagnostic System Check</i>	–

DTC 04 – Driver Firing Circuit, Short To Battery Voltage

Step	Action	Value(s)	Yes	No
1	Visually inspect the supplemental inflatable restraints (SIR) harness for damage. Is there any visible damage to the SIR harness?	–	Go to <i>Step 2</i>	Go to <i>Step 3</i>
2	1. Replace the SIR wiring harness. 2. Reconnect the negative battery cable. Is your repair complete?	–	Go to <i>Diagnostic System Check</i>	–
3	1. Remove the driver airbag module. 2. Place the driver airbag module in a secure position with the decorative surface facing upward. 3. Disconnect the electrical connector at the SDM. <ul style="list-style-type: none"> The shorting bar at the disconnected SDM connector will create a complete circuit between the wires from the driver airbag module. 4. Use a multimeter to check the voltage at one of the terminals on the wiring harness connector for the driver airbag module. <ul style="list-style-type: none"> Refer to “Diagnostic Illustration 6” in this section. Is the voltage greater than the specified value?	0 v	Go to <i>Step 6</i>	Go to <i>Step 4</i>
4	1. Replace the SDM. 2. Reconnect the negative battery cable. 3. Set the scan tool for CODE ERASE. 4. Do the diagnostic system check. Does the code 04 still show as a current fault?	–	Go to <i>Step 5</i>	System OK
5	1. Replace the driver airbag module. 2. Reconnect the negative battery cable. Is the repair complete?	–	Go to <i>Diagnostic System Check</i>	–
6	1. Disconnect the clock spring wiring harness at the lower steering column. <ul style="list-style-type: none"> The shorting bar at the disconnected SDM connector will create a complete circuit between the wires from the clock spring connector. 2. Using a multimeter, check the voltage at one of the terminals on the SDM side of the clock spring connector. <ul style="list-style-type: none"> Refer to “Diagnostic Illustration 7” in this section. Did the voltmeter indicate the specified value?	0 v	Go to <i>Step 7</i>	Go to <i>Step 2</i>
7	1. Replace the clock spring. 2. Reconnect the negative battery cable. Is the repair complete?	–	Go to <i>Diagnostic System Check</i>	–

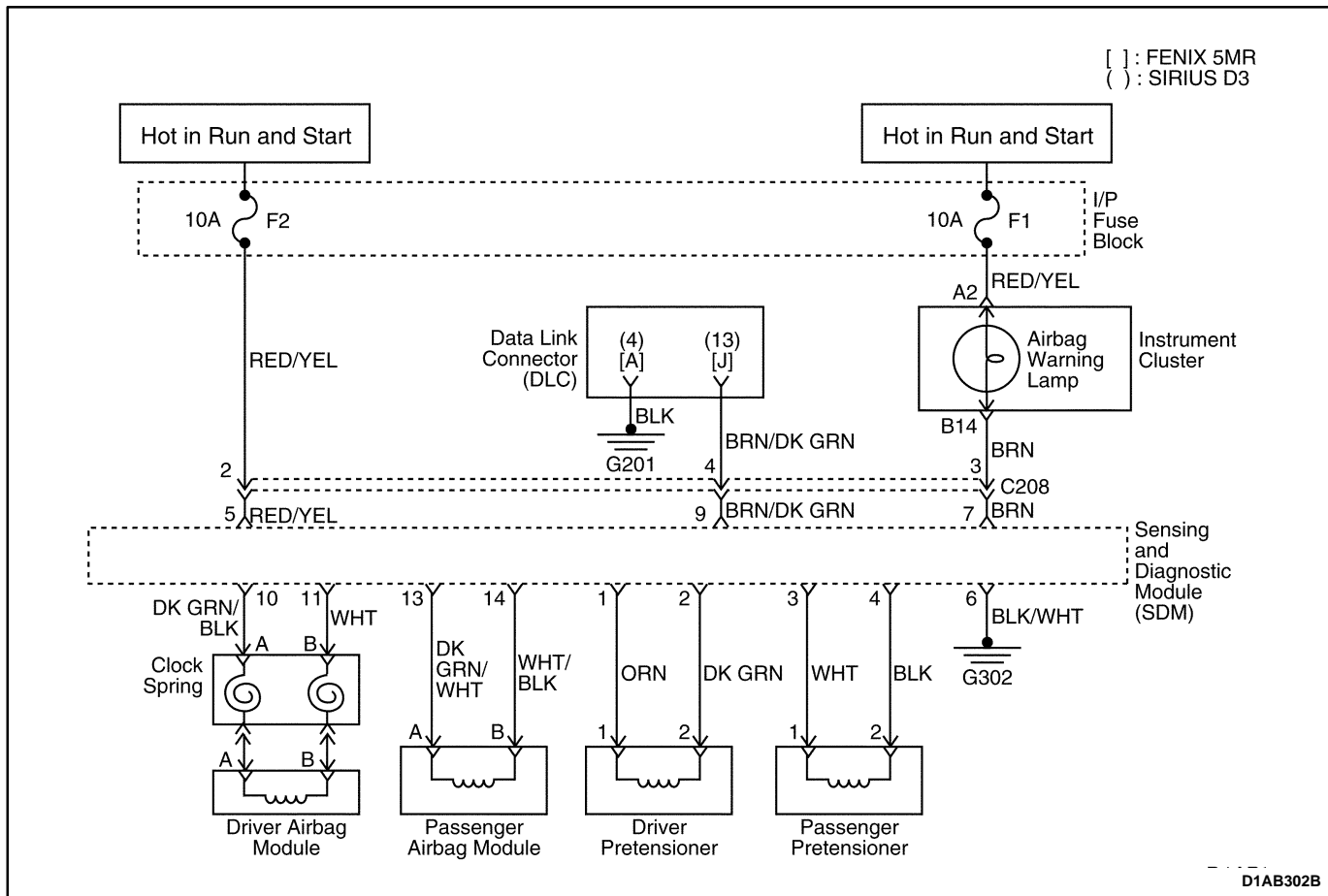

DIAGNOSTIC TROUBLE CODE (DTC) 05 PASSENGER FIRING CIRCUIT, RESISTANCE TOO HIGH

Open Circuit

Circuit Description

When the ignition switch is turned ON, the sensing and diagnostic module (SDM) will perform tests to diagnose any malfunctions within itself.

After passing these tests, the SDM will check the passenger airbag firing circuit. The SDM allows a very small amount of current to flow through the circuit. The SDM monitors the circuit resistance during this check.

DTC 05 Will Set When

- The combined resistance of the passenger airbag module, the harness wiring, and the connector contacts is above a specified value, as in an open circuit.

Test Description

Caution: Before testing, disconnect the negative battery cable. Wait 1 minute for the SDM capacitor to discharge. The capacitor supplies reserve power to deploy the airbags, even if the battery is disconnected. Unintentional deployment of the airbags can cause injury.

Caution: Never measure the resistance of an airbag module. If the anti-deployment shorting bar on the module-side of the connector is not working properly, the meter's battery can deploy the airbag and cause injury.

DTC 05 – Passenger Firing Circuit, Resistance Too High

Step	Action	Value(s)	Yes	No
1	1. Disconnect the negative battery cable. 2. Wait 1 minute for the SDM capacitor to discharge. 3. Examine the wiring and the connector at the passenger side airbag module. Is the connector disconnected?	–	Go to <i>Step 2</i>	Go to <i>Step 3</i>
2	1. Reconnect the passenger side airbag module connector. 2. Reconnect the negative battery cable. Is the repair complete?	–	Go to <i>Diagnostic System Check</i>	–
3	1. Disconnect the electrical connector for the passenger side airbag module. 2. Disconnect the electrical connector at the SDM. <ul style="list-style-type: none"> ● The shorting bar at the disconnected SDM connector will create a complete circuit between the wires from the passenger airbag module. 3. Connect an ohmmeter to the terminals on the SDM side of the wiring harness connector for the passenger side airbag module. <ul style="list-style-type: none"> ● Refer to “Diagnostic Illustration 8” in this section. Does the ohmmeter show the specified value?	≈ 0 Ω	Go to <i>Step 4</i>	Go to <i>Step 6</i>
4	1. Replace the SDM. 2. Reconnect the negative battery cable. 3. Set the scan tool for CODE ERASE. 4. Do the diagnostic system check. Does the code 05 still show as a current fault?	–	Go to <i>Step 5</i>	System OK
5	1. Replace the passenger side airbag module. 2. Reconnect the negative battery cable. Is the repair complete?	–	Go to <i>Diagnostic System Check</i>	–
6	1. Replace the supplemental inflatable restraints (SIR) wiring harness. 2. Reconnect the negative battery cable. Is the repair complete?	–	Go to <i>Diagnostic System Check</i>	–

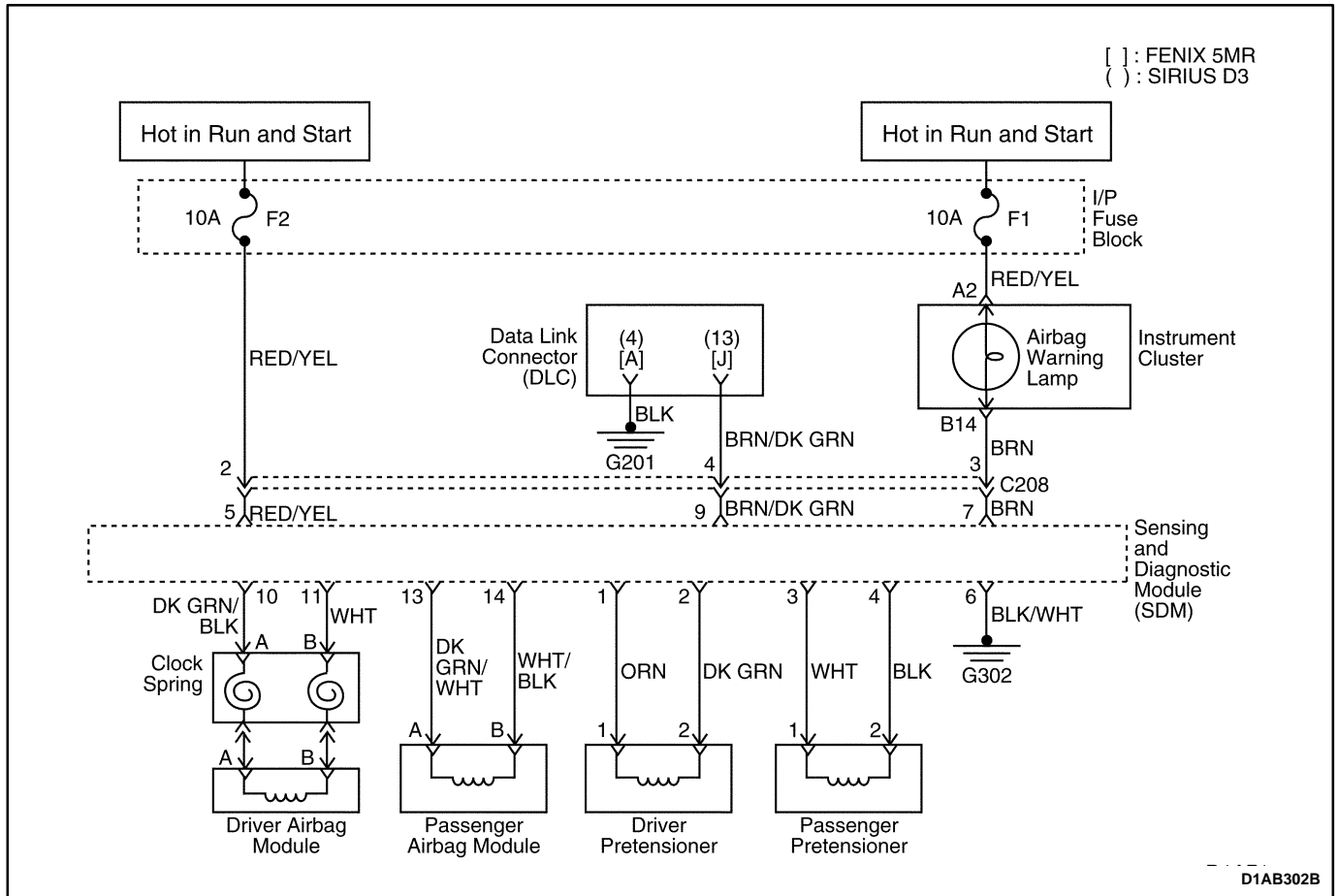

DIAGNOSTIC TROUBLE CODE (DTC) 06 PASSENGER FIRING CIRCUIT, RESISTANCE TOO LOW

Short Circuit

Circuit Description

When the ignition switch is turned ON, the sensing and diagnostic module (SDM) will perform tests to diagnose any malfunctions within itself.

After passing these tests, the SDM will check the passenger airbag firing circuit. The SDM allows a very small amount of current to flow through the circuit. The SDM monitors the circuit resistance during this check.

DTC 06 Will Set When

- The combined resistance of the passenger airbag module, the harness wiring, and the connector contacts is below a specified value, as in a short circuit between the wires to the passenger airbag module.

Test Description

Caution: Before testing, disconnect the negative battery cable. Wait 1 minute for the SDM capacitor to discharge. The capacitor supplies reserve power to deploy the airbags, even if the battery is disconnected. Unintentional deployment of the airbags can cause injury.

Caution: Never measure the resistance of an airbag module. If the anti-deployment shorting bar on the module side of the connector is not working properly, the meter's battery could deploy the airbag and cause injury.

DTC 06 – Passenger Firing Circuit, Resistance Too Low

Step	Action	Value(s)	Yes	No
1	1. Disconnect the negative battery cable. 2. Connect an ohmmeter to the terminals of the wiring harness connector for the passenger airbag module on the SDM side of the connector. • Refer to “Diagnostic Illustration 8” in this section. Does the ohmmeter show the specified value?	∞	Go to <i>Step 2</i>	Go to <i>Step 4</i>
2	1. Replace the SDM. 2. Reconnect the negative battery cable. 3. Set the scan tool to CODE ERASE. 4. Do the diagnostic system check. Does the code 06 still show as a current fault?	–	Go to <i>Step 3</i>	System OK
3	1. Replace the passenger airbag module. 2. Reconnect the negative battery cable. Is the repair complete?	–	Go to <i>Diagnostic System Check</i>	–
4	1. Replace the supplemental inflatable restraints (SIR) wiring harness. 2. Reconnect the negative battery cable. Is the repair complete?	–	Go to <i>Diagnostic System Check</i>	–

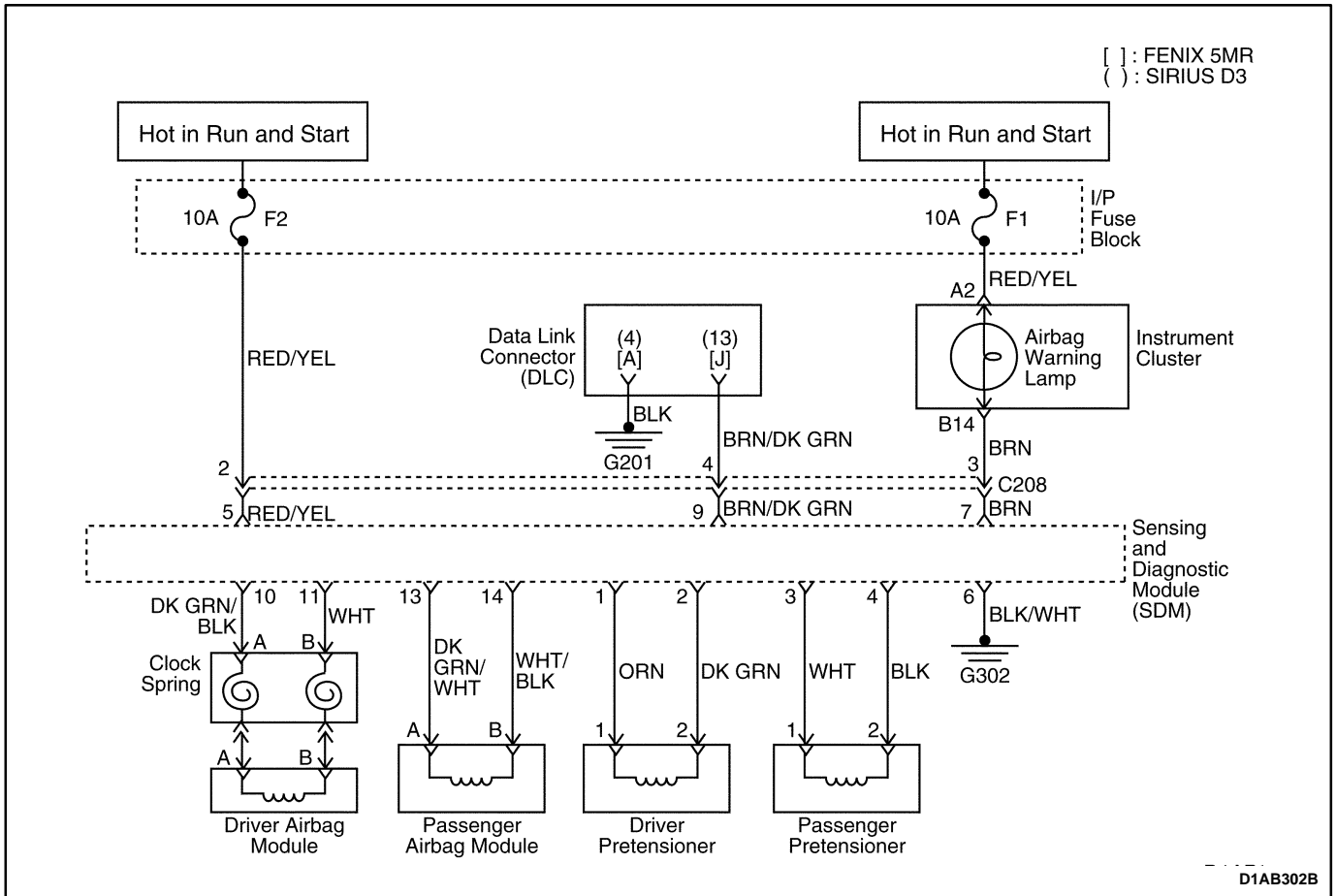

DIAGNOSTIC TROUBLE CODE (DTC) 07 PASSENGER FIRING CIRCUIT, SHORT TO GROUND

Circuit Description

When the ignition switch is turned ON, the sensing and diagnostic module (SDM) will diagnose any malfunctions within itself.

After passing these tests, the SDM will check the passenger airbag firing circuit. The SDM allows a very small amount of current to flow through the circuit. The SDM monitors the voltage during this check.

DTC 07 Will Set When

- The firing circuit is shorted to ground.

Test Description

Caution: Before testing, disconnect the negative battery cable. Wait 1 minute for the SDM capacitor to discharge. The capacitor supplies reserve power to deploy the airbags, even if the battery is disconnected. Unintentional deployment of the airbags can cause injury.

DTC 07 Passenger Firing Circuit, Short To Ground

Step	Action	Value(s)	Yes	No
1	1. Disconnect the negative battery cable. 2. Wait 1 minute for the SDM capacitor to discharge. 3. Visually inspect the supplemental inflatable restraints (SIR) wiring harness. Is there any visible damage to the SIR harness?	-	Go to <i>Step 2</i>	Go to <i>Step 3</i>
2	1. Replace the SIR wiring harness. 2. Reconnect the negative battery cable. Is the repair complete?	-	Go to <i>Diagnostic System Check</i>	-
3	1. Disconnect the electrical connector from the passenger airbag module. 2. Disconnect the electrical connector at the SDM. <ul style="list-style-type: none"> ● The shorting bar at the disconnected SDM connector will create a complete circuit between the wires from the passenger side airbag module. 3. Use an ohmmeter to check the continuity between ground and one of the terminals at the SDM side of the wiring harness connector for the passenger side airbag module. <ul style="list-style-type: none"> ● Refer to "Diagnostic Illustration 9" in this section. Is the resistance less than the specified value?	∞	Go to <i>Step 2</i>	Go to <i>Step 4</i>
4	1. Replace the SDM. 2. Reconnect the negative battery cable. 3. Set the scan tool to CODE ERASE. 4. Do the diagnostic system check. Does the code 07 still show as a current fault?	-	Go to <i>Step 5</i>	System OK
5	1. Replace the passenger side airbag module. 2. Reconnect the negative battery cable. Is the repair complete?	-	Go to <i>Diagnostic System Check</i>	-

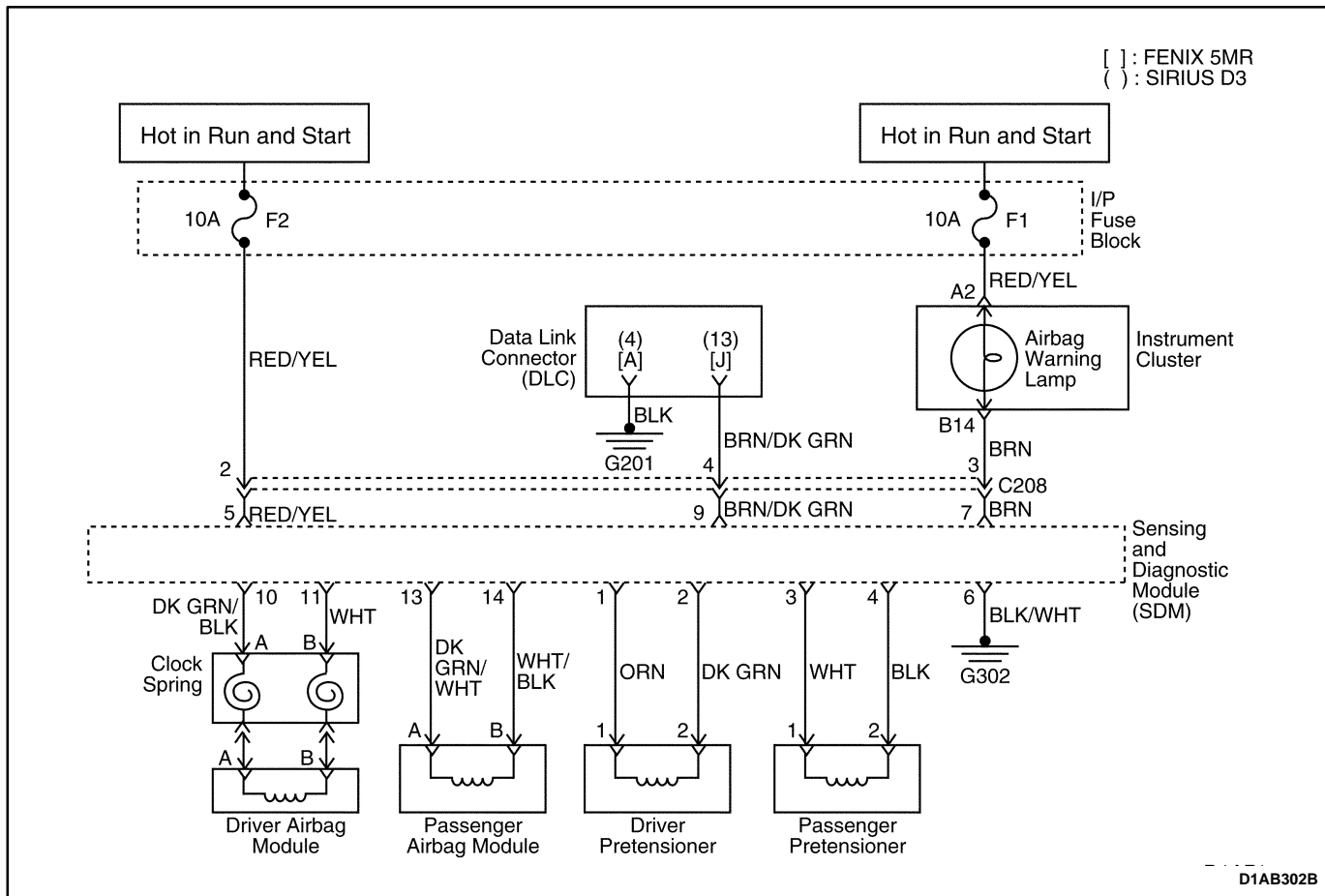

DIAGNOSTIC TROUBLE CODE (DTC) 08 PASSENGER FIRING CIRCUIT, SHORT TO BATTERY VOLTAGE

Circuit Description

When the ignition switch is turned ON, the sensing and diagnostic module (SDM) will perform tests to diagnose any malfunctions within itself.

After passing these tests, the SDM will check the passenger airbag firing circuit. The SDM allows a very small amount of current to flow through the circuit. The SDM monitors the voltage during this check.

DTC 08 Will Set When

- The firing circuit is shorted to the voltage.

Test Description

Caution: Before testing, disconnect the negative battery cable. Wait 1 minute for the SDM capacitor to discharge. The capacitor supplies the reserve power to deploy the airbags, even if the battery is disconnected. Unintentional deployment of the airbags can cause injury.

D1AB302B

DTC 08 – Passenger Firing Circuit, Short To Battery Voltage

Step	Action	Value(s)	Yes	No
1	1. Disconnect the battery negative cable. 2. Wait 1 minute for the SDM capacitor to discharge. <ul style="list-style-type: none"> • The capacitor supplies reserve power to deploy the passenger side airbag even if the battery has been disconnected. 3. Visually inspect the supplemental inflatable restraints (SIR) wiring harness. Is there any visible damage to the SIR wiring harness?	–	Go to <i>Step 2</i>	Go to <i>Step 3</i>
2	1. Replace the SIR wiring harness. 2. Reconnect the negative battery cable. Is the repair complete?	–	Go to <i>Diagnostic System Check</i>	–
3	1. Disconnect the electrical connector for the passenger airbag module. 2. Disconnect the electrical connector at the SDM. <ul style="list-style-type: none"> • The shorting bar at the disconnected SDM connector will create a complete circuit between the wires from the passenger airbag module. 3. Use a multimeter to check the voltage at one of the terminals on the SDM side of the SIR wiring harness connector for the passenger airbag module. <ul style="list-style-type: none"> • Refer to “Diagnostic Illustration 10” in this section. Is the voltage greater than the specified value?	0 v	Go to <i>Step 2</i>	Go to <i>Step 4</i>
4	1. Replace the SDM. 2. Reconnect the negative battery cable. 3. Set the scan tool to CODE ERASE. 4. Do the diagnostic system check. Does the code 08 still show as a current fault?	–	Go to <i>Step 5</i>	System OK
5	1. Replace the passenger side airbag module. 2. Reconnect the negative battery cable. Is the repair complete?	–	Go to <i>Diagnostic System Check</i>	–

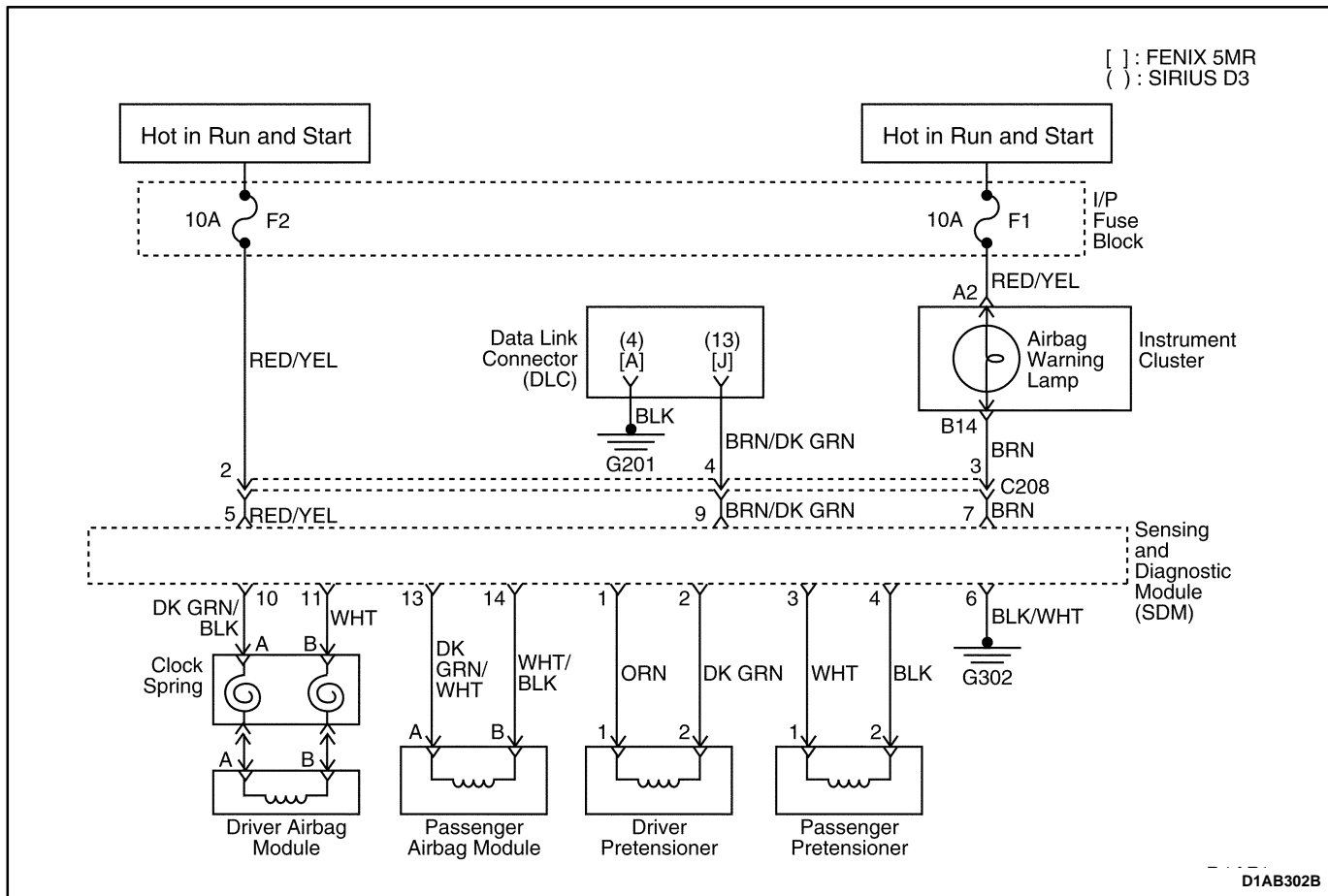

DIAGNOSTIC TROUBLE CODE (DTC) 09 DRIVER PRETENSIONER CIRCUIT, RESISTANCE TOO HIGH

Open Circuit

Circuit Description

When the ignition switch is turned ON, the sensing and diagnostic module (SDM) will perform tests to diagnose any malfunctions within itself.

After passing these tests, the SDM will check the driver pretensioner circuit. The SDM allows a very small amount of current to flow through the circuit. The SDM monitors the circuit resistance during this check.

DTC 09 Will Set When

- The combined resistance of the driver pretensioner module, the harness wiring, and the connector contacts is above a specified value, as in an open circuit.

Test Description

Caution: Before testing, disconnect the negative battery cable. Wait 1 minute for the SDM capacitor to discharge. The capacitor supplies reserve power to deploy the airbags, even if the battery is disconnected. Unintentional deployment of the airbags can cause injury.

Caution: Never measure the resistance of an airbag module. If the anti-deployment shorting bar on the module-side of the connector is not working properly, the meter's battery can deploy the airbag and cause injury.

DTC 09 – Driver Pretensioner Circuit, Resistance Too High

Step	Action	Value(s)	Yes	No
1	1. Disconnect the negative battery cable. 2. Wait 1 minute for the SDM capacitor to discharge. 3. Examine the wiring and the connector at the driver seat belt pretensioner module. Is the connector disconnected?	–	Go to <i>Step 2</i>	Go to <i>Step 3</i>
2	1. Reconnect the driver seat belt pretensioner module connector. 2. Reconnect the negative battery cable. Is the repair complete?	–	Go to <i>Diagnostic System Check</i>	–
3	1. Disconnect the electrical connector for the driver seat belt pretensioner module. 2. Disconnect the electrical connector at the SDM. <ul style="list-style-type: none"> ● The shorting bar at the disconnected SDM connector will create a complete circuit between the wires from the driver seat belt pretensioner module. 3. Connect an ohmmeter to the terminals on the SDM side of the wiring harness connector for the driver seat belt pretensioner module. <ul style="list-style-type: none"> ● Refer to “Diagnostic Illustration 16” in this section. Does the ohmmeter show the specified value?	$\approx 0 \Omega$	Go to <i>Step 4</i>	Go to <i>Step 6</i>
4	1. Replace the SDM. 2. Reconnect the negative battery cable. 3. Set the scan tool for CODE ERASE. 4. Do the diagnostic system check. Does the code 09 still show as a current fault?	–	Go to <i>Step 5</i>	System OK
5	1. Replace the driver seat belt pretensioner module. 2. Reconnect the negative battery cable. Is the repair complete?	–	Go to <i>Diagnostic System Check</i>	–
6	1. Replace the supplemental inflatable restraints (SIR) wiring harness. 2. Reconnect the negative battery cable. Is the repair complete?	–	Go to <i>Diagnostic System Check</i>	–

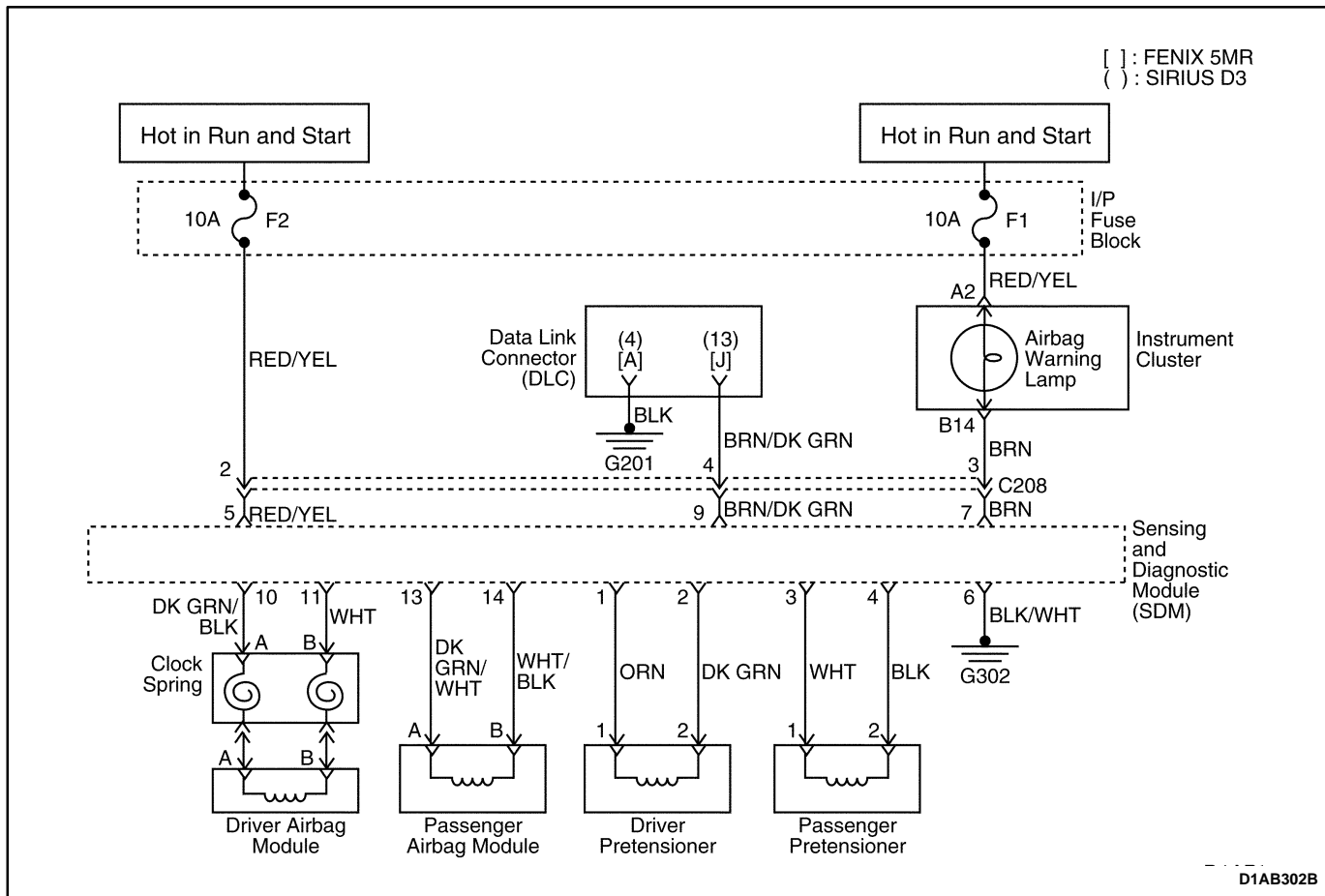

DIAGNOSTIC TROUBLE CODE (DTC) 10 DRIVER PRETENSIONER CIRCUIT, RESISTANCE TOO LOW

Short Circuit

Circuit Description

When the ignition switch is turned ON, the sensing and diagnostic module (SDM) will perform tests to diagnose any malfunctions within itself.

After passing these tests, the SDM will check the driver pretensioner circuit. The SDM allows a very small amount of current to flow through the pretensioner circuit. The SDM monitors the circuit resistance during this check.

DTC 10 Will Set When

- The combined resistance of the driver pretensioner the harness wiring, and the connector contacts is below a specified value, as with a short circuit between the wires to the driver airbag module.

Test Description

Caution: Before testing, disconnect the negative battery cable. Wait 1 minute for the SDM capacitor to discharge. The capacitor supplies reserve power to deploy the airbags, even if the battery is disconnected. Unintentional deployment of the airbags can cause injury.

Caution: Never measure the resistance of an airbag module with an ohmmeter. An ohmmeter's battery can deploy the airbag and cause injury.

DTC 10 – Driver Pretensioner Circuit, Resistance Too Low

Step	Action	Value(s)	Yes	No
1	1. Disconnect the negative battery cable. 2. Connect an ohmmeter to the terminals of the wiring harness connector for the driver seat belt pretensioner module on the SDM side of the connector. • Refer to “Diagnostic Illustration 16” in this section. Does the ohmmeter show the specified value?	∞	Go to <i>Step 2</i>	Go to <i>Step 4</i>
2	1. Replace the SDM. 2. Reconnect the negative battery cable. 3. Set the scan tool to CODE ERASE. 4. Do the diagnostic system check. Does the code 10 still show as a current fault?	–	Go to <i>Step 3</i>	System OK
3	1. Replace the driver seat belt pretensioner module. 2. Reconnect the negative battery cable. Is the repair complete?	–	Go to <i>Diagnostic System Check</i>	–
4	1. Replace the supplemental inflatable restraints (SIR) wiring harness. 2. Reconnect the negative battery cable. Is the repair complete?	–	Go to <i>Diagnostic System Check</i>	–

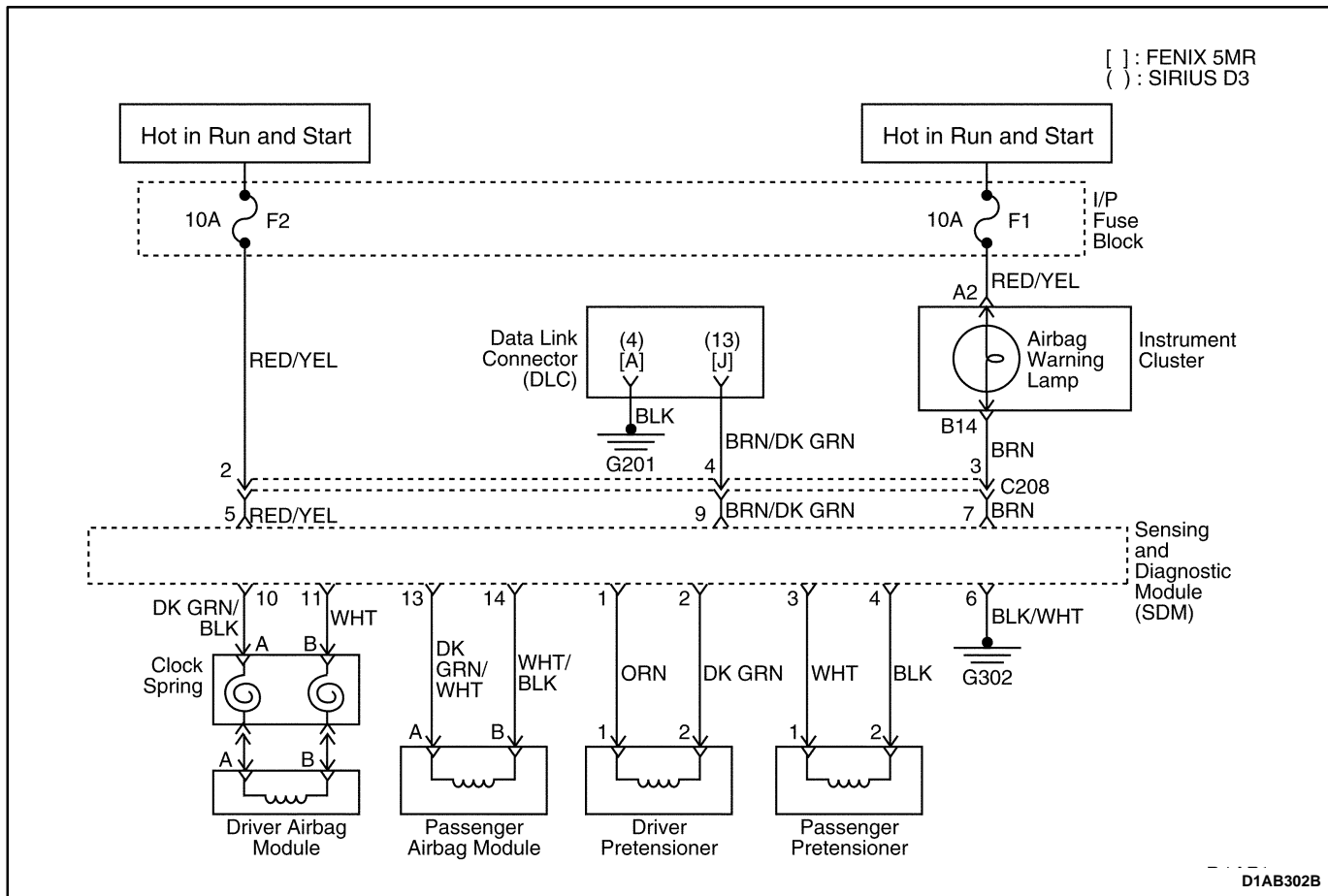

DIAGNOSTIC TROUBLE CODE (DTC) 11 DRIVER PRETENSIONER CIRCUIT, SHORT TO GROUND

Circuit Description

When the ignition switch is turned ON, the sensing and diagnostic module (SDM) will perform tests to diagnose any malfunctions within itself.

After passing these tests, the SDM will check the driver pretensioner circuit. The SDM allows a very small amount of current to flow through the driver pretensioner circuit. The SDM monitors the voltage during this check.

DTC 11 Will Set When

- The firing circuit is shorted to ground.

Test Description

Caution: Before testing, disconnect the negative battery cable. Wait 1 minute for the SDM capacitor to discharge. The capacitor supplies reserve power to deploy the airbags, even if the battery is disconnected. Unintentional deployment of the airbags can cause injury.

DTC 11 Driver Pretensioner Circuit, Short To Ground

Step	Action	Value(s)	Yes	No
1	1. Disconnect the negative battery cable. 2. Wait 1 minute for the SDM capacitor to discharge. 3. Visually inspect the supplemental inflatable restraints (SIR) wiring harness. Is there any visible damage to the SIR harness?	–	Go to <i>Step 2</i>	Go to <i>Step 3</i>
2	1. Replace the SIR wiring harness. 2. Reconnect the negative battery cable. Is the repair complete?	–	Go to <i>Diagnostic System Check</i>	–
3	1. Disconnect the electrical connector from the driver seat belt pretensioner module. 2. Disconnect the electrical connector at the SDM. <ul style="list-style-type: none"> ● The shorting bar at the disconnected SDM connector will create a complete circuit between the wires from the driver seat belt pretensioner module. 3. Use an ohmmeter to check the continuity between ground and one of the terminals at the SDM side of the wiring harness connector for the driver seat belt pretensioner module. <ul style="list-style-type: none"> ● Refer to “Diagnostic Illustration 17” in this section. Is the resistance less than the specified value?	∞	Go to <i>Step 2</i>	Go to <i>Step 4</i>
4	1. Replace the SDM. 2. Reconnect the negative battery cable. 3. Set the scan tool to CODE ERASE. 4. Do the diagnostic system check. Does the code 11 still show as a current fault?	–	Go to <i>Step 5</i>	System OK
5	1. Replace the driver seat belt pretensioner module. 2. Reconnect the negative battery cable. Is the repair complete?	–	Go to <i>Diagnostic System Check</i>	–

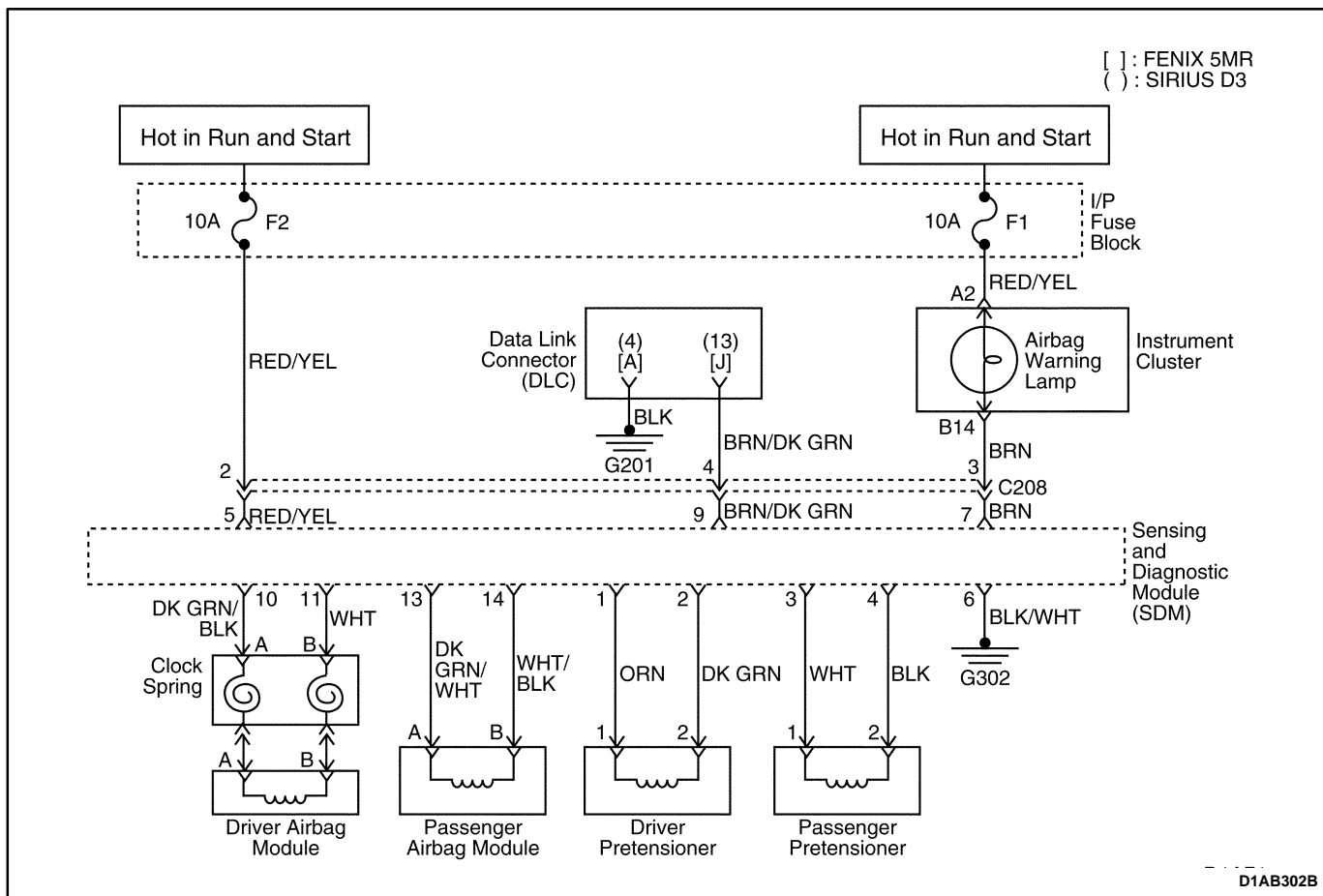

DIAGNOSTIC TROUBLE CODE (DTC) 12 DRIVER PRETENSIONER CIRCUIT, SHORT TO BATTERY VOLTAGE

Circuit Description

When the ignition switch is turned ON, the sensing and diagnostic module (SDM) will perform tests to diagnose any malfunctions within itself.

After passing these tests, the SDM will check the driver pretensioner circuit. The SDM allows a very small amount of current to flow through the circuit. The SDM monitors voltage during this check.

DTC 12 Will Set When

- The firing circuit is shorted to voltage.

Test Description

Caution: Before testing, disconnect the negative battery cable. Wait 1 minute for the SDM capacitor to discharge. The capacitor supplies reserve power to deploy the airbags, even if the battery is disconnected. Unintentional deployment of the airbags can cause injury.

DTC 12 – Driver Pretensioner Circuit, Short To Battery Voltage

Step	Action	Value(s)	Yes	No
1	1. Disconnect the battery negative cable. 2. Wait 1 minute for the SDM capacitor to discharge. <ul style="list-style-type: none"> • The capacitor supplies reserve power to deploy the driver seat belt pretensioner even if the battery has been disconnected. 3. Visually inspect the supplemental inflatable restraints (SIR) wiring harness. Is there any visible damage to the SIR wiring harness?	–	Go to <i>Step 2</i>	Go to <i>Step 3</i>
2	1. Replace the SIR wiring harness. 2. Reconnect the negative battery cable. Is the repair complete?	–	Go to <i>Diagnostic System Check</i>	–
3	1. Disconnect the electrical connector for the driver seat belt pretensioner module. 2. Disconnect the electrical connector at the SDM. <ul style="list-style-type: none"> • The shorting bar at the disconnected SDM connector will create a complete circuit between the wires from the driver seat belt pretensioner module. 3. Use a multimeter to check the voltage at one of the terminals on the SDM side of the SIR wiring harness connector for the driver seat belt pretensioner module. <ul style="list-style-type: none"> • Refer to “Diagnostic Illustration 18” in this section. Is the voltage greater than the specified value?	0 v	Go to <i>Step 2</i>	Go to <i>Step 4</i>
4	1. Replace the SDM. 2. Reconnect the negative battery cable. 3. Set the scan tool to CODE ERASE. 4. Do the diagnostic system check. Does the code 12 still show as a current fault?	–	Go to <i>Step 5</i>	System OK
5	1. Replace the driver seat belt pretensioner module. 2. Reconnect the negative battery cable. Is the repair complete?	–	Go to <i>Diagnostic System Check</i>	–

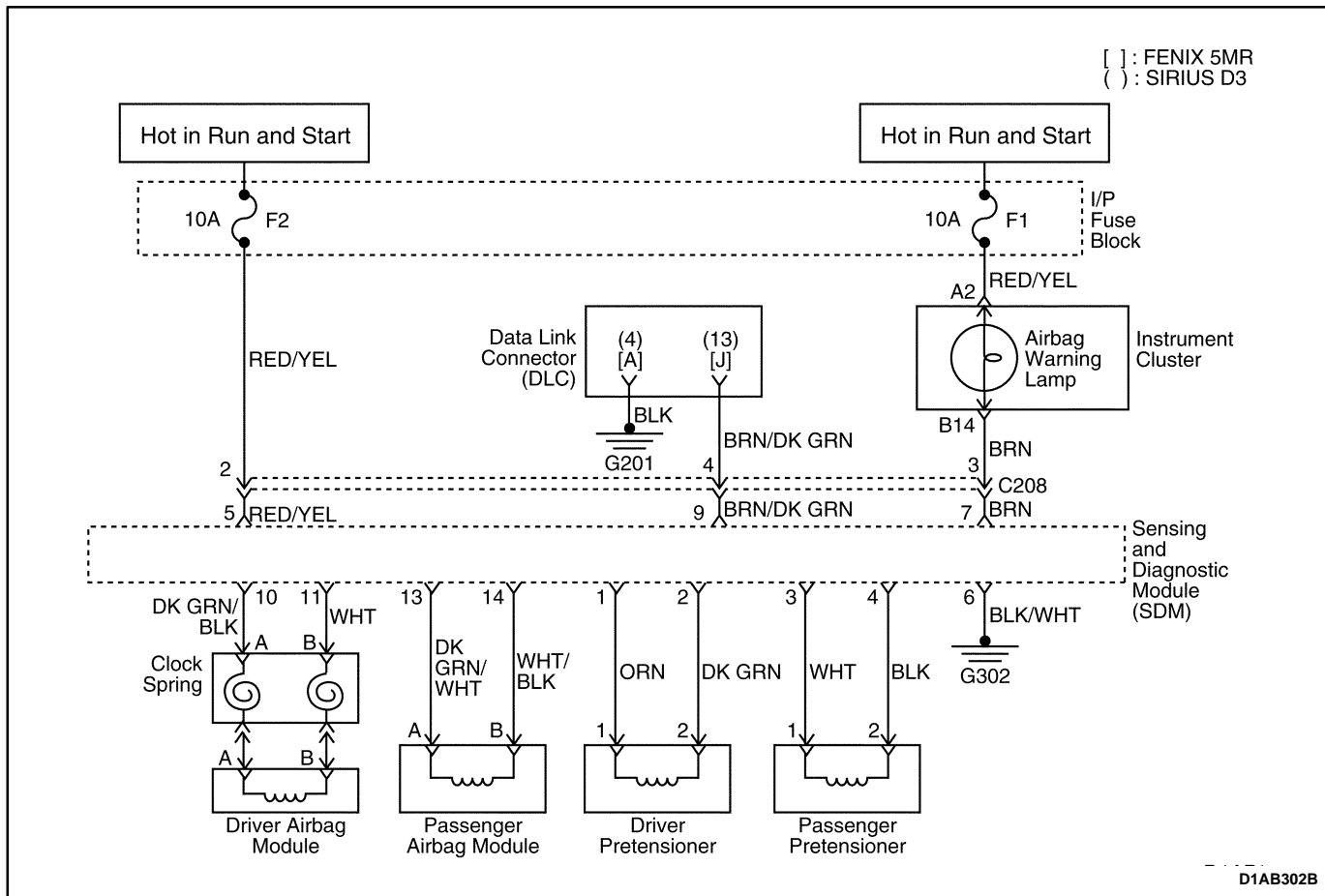

DIAGNOSTIC TROUBLE CODE (DTC) 13 PASSENGER PRETENSIONER CIRCUIT, RESISTANCE TOO HIGH

Open Circuit

Circuit Description

When the ignition switch is turned ON, the sensing and diagnostic module (SDM) will perform tests to diagnose any malfunctions within itself.

After passing these tests, the SDM will check the passenger pretensioner circuit. The SDM allows a very small amount of current to flow through the circuit. The SDM monitors the circuit resistance during this check.

DTC 13 Will Set When

- The combined resistance of the passenger pretensioner module, the harness wiring, and the connector contacts is above a specified value, as in an open circuit.

Test Description

Caution: Before testing, disconnect the negative battery cable. Wait 1 minute for the SDM capacitor to discharge. The capacitor supplies reserve power to deploy the airbags, even if the battery is disconnected. Unintentional deployment of the airbags can cause injury.

Caution: Never measure the resistance of an airbag module. If the anti-deployment shorting bar on the module-side of the connector is not working properly, the meter's battery can deploy the airbag and cause injury.

DTC 13 – Passenger Pretensioner Circuit, Resistance Too High

Step	Action	Value(s)	Yes	No
1	1. Disconnect the negative battery cable. 2. Wait 1 minute for the SDM capacitor to discharge. 3. Examine the wiring and the connector at the passenger seat belt pretensioner module. Is the connector disconnected?	–	Go to <i>Step 2</i>	Go to <i>Step 3</i>
2	1. Reconnect the passenger seat belt pretensioner module connector. 2. Reconnect the negative battery cable. Is the repair complete?	–	Go to <i>Diagnostic System Check</i>	–
3	1. Disconnect the electrical connector for the passenger seat belt pretensioner module. 2. Disconnect the electrical connector at the SDM. <ul style="list-style-type: none"> ● The shorting bar at the disconnected SDM connector will create a complete circuit between the wires from the passenger seat belt pretensioner module. 3. Connect an ohmmeter to the terminals on the SDM side of the wiring harness connector for the passenger seat belt pretensioner module. <ul style="list-style-type: none"> ● Refer to “Diagnostic Illustration 19” in this section. Does the ohmmeter show the specified value?	≈ 0 Ω	Go to <i>Step 4</i>	Go to <i>Step 6</i>
4	1. Replace the SDM. 2. Reconnect the negative battery cable. 3. Set the scan tool for CODE ERASE. 4. Do the diagnostic system check. Does the code 13 still show as a current fault?	–	Go to <i>Step 5</i>	System OK
5	1. Replace the passenger seat belt pretensioner module. 2. Reconnect the negative battery cable. Is the repair complete?	–	Go to <i>Diagnostic System Check</i>	–
6	1. Replace the supplemental inflatable restraints (SIR) wiring harness. 2. Reconnect the negative battery cable. Is the repair complete?	–	Go to <i>Diagnostic System Check</i>	–

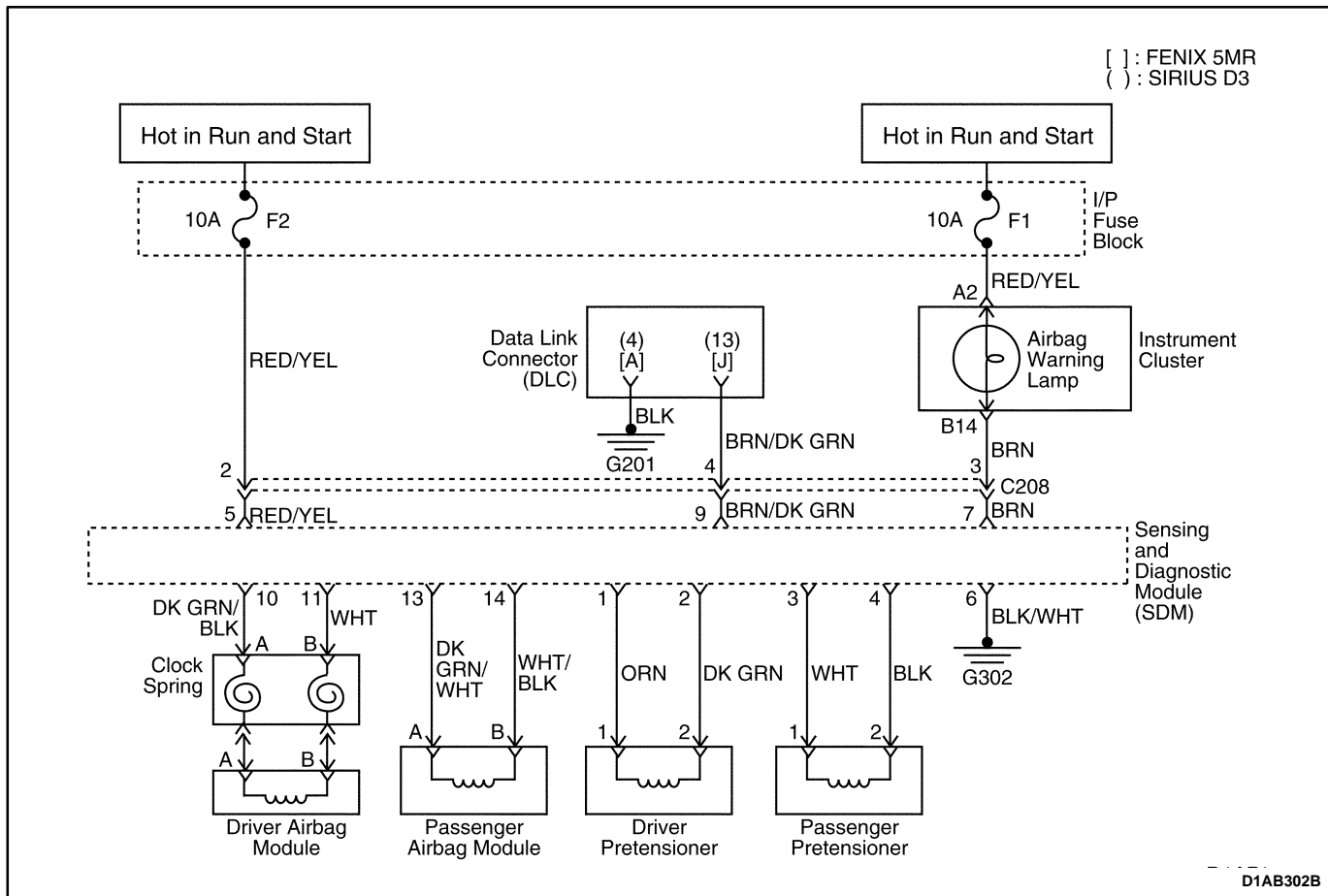

DIAGNOSTIC TROUBLE CODE (DTC) 14 PASSENGER PRETENSIONER CIRCUIT, RESISTANCE TOO LOW

Short Circuit

Circuit Description

When the ignition switch is turned ON, the sensing and diagnostic module (SDM) will perform tests to diagnose any malfunctions within itself.

After passing these tests, the SDM will check the passenger pretensioner circuit. The SDM allows a very small amount of current to flow through the circuit. The SDM monitors the circuit resistance during this check.

DTC 14 Will Set When

- The combined resistance of the passenger pretensioner module, the harness wiring, and the connector contacts is below a specified value, as in a short circuit between the wires to the passenger airbag module.

Test Description

Caution: Before testing, disconnect the negative battery cable. Wait 1 minute for the SDM capacitor to discharge. The capacitor supplies reserve power to deploy the airbags, even if the battery is disconnected. Unintentional deployment of the airbags can cause injury.

Caution: Never measure the resistance of an airbag module. If the anti-deployment shorting bar on the module side of the connector is not working properly, the meter's battery could deploy the airbag and cause injury.

DTC 14 – Passenger Pretensioner Circuit, Resistance Too Low

Step	Action	Value(s)	Yes	No
1	1. Disconnect the negative battery cable. 2. Connect an ohmmeter to the terminals of the wiring harness connector for the passenger seat belt pretensioner module on the SDM side of the connector. • Refer to “Diagnostic Illustration 19” in this section. Does the ohmmeter show the specified value?	∞	Go to <i>Step 2</i>	Go to <i>Step 4</i>
2	1. Replace the SDM. 2. Reconnect the negative battery cable. 3. Set the scan tool to CODE ERASE. 4. Do the diagnostic system check. Does the code 14 still show as a current fault?	–	Go to <i>Step 3</i>	System OK
3	1. Replace the passenger seat belt pretensioner module. 2. Reconnect the negative battery cable. Is the repair complete?	–	Go to <i>Diagnostic System Check</i>	–
4	1. Replace the supplemental inflatable restraints (SIR) wiring harness. 2. Reconnect the negative battery cable. Is the repair complete?	–	Go to <i>Diagnostic System Check</i>	–

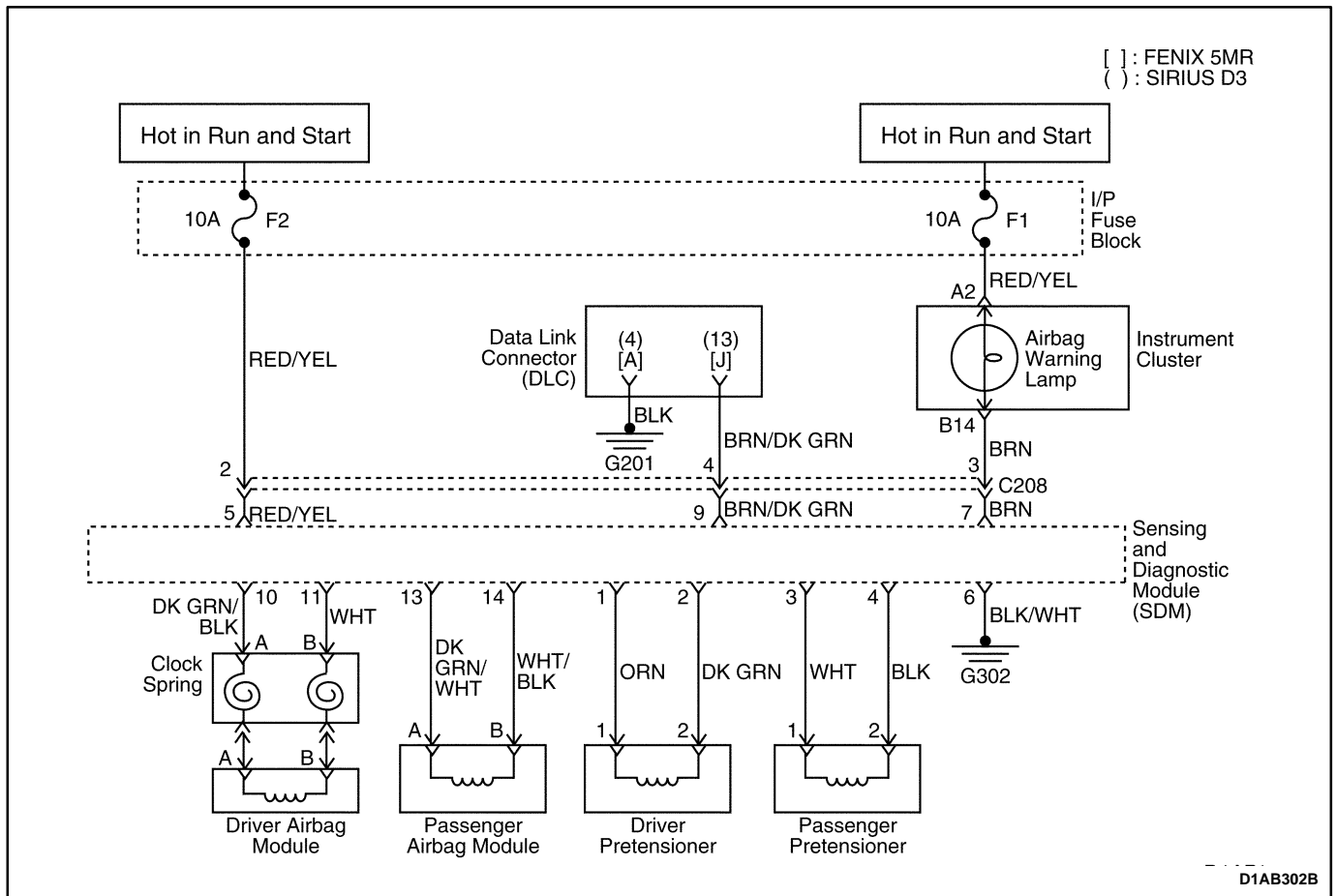

DIAGNOSTIC TROUBLE CODE (DTC) 15 PASSENGER PRETENSIONER CIRCUIT, SHORT TO GROUND

Circuit Description

When the ignition switch is turned ON, the sensing and diagnostic module (SDM) will diagnose any malfunctions within itself.

After passing these tests, the SDM will check the passenger pretensioner circuit. The SDM allows a very small amount of current to flow through the circuit. The SDM monitors the voltage during this check.

DTC 15 Will Set When

- The firing circuit is shorted to ground.

Test Description

Caution: Before testing, disconnect the negative battery cable. Wait 1 minute for the SDM capacitor to discharge. The capacitor supplies reserve power to deploy the airbags, even if the battery is disconnected. Unintentional deployment of the airbags can cause injury.

DTC 15 Passenger Pretensioner Circuit, Short To Ground

Step	Action	Value(s)	Yes	No
1	1. Disconnect the negative battery cable. 2. Wait 1 minute for the SDM capacitor to discharge. 3. Visually inspect the supplemental inflatable restraints (SIR) wiring harness. Is there any visible damage to the SIR harness?	-	Go to <i>Step 2</i>	Go to <i>Step 3</i>
2	1. Replace the SIR wiring harness. 2. Reconnect the negative battery cable. Is the repair complete?	-	Go to <i>Diagnostic System Check</i>	-
3	1. Disconnect the electrical connector from the passenger seat belt pretensioner module. 2. Disconnect the electrical connector at the SDM. <ul style="list-style-type: none"> ● The shorting bar at the disconnected SDM connector will create a complete circuit between the wires from the passenger seat belt pretensioner module. 3. Use an ohmmeter to check the continuity between ground and one of the terminals at the SDM side of the wiring harness connector for the passenger seat belt pretensioner module. <ul style="list-style-type: none"> ● Refer to "Diagnostic Illustration 20" in this section. Is the resistance less than the specified value?	∞	Go to <i>Step 2</i>	Go to <i>Step 4</i>
4	1. Replace the SDM. 2. Reconnect the negative battery cable. 3. Set the scan tool to CODE ERASE. 4. Do the diagnostic system check. Does the code 15 still show as a current fault?	-	Go to <i>Step 5</i>	System OK
5	1. Replace the passenger seat belt pretensioner module. 2. Reconnect the negative battery cable. Is the repair complete?	-	Go to <i>Diagnostic System Check</i>	-

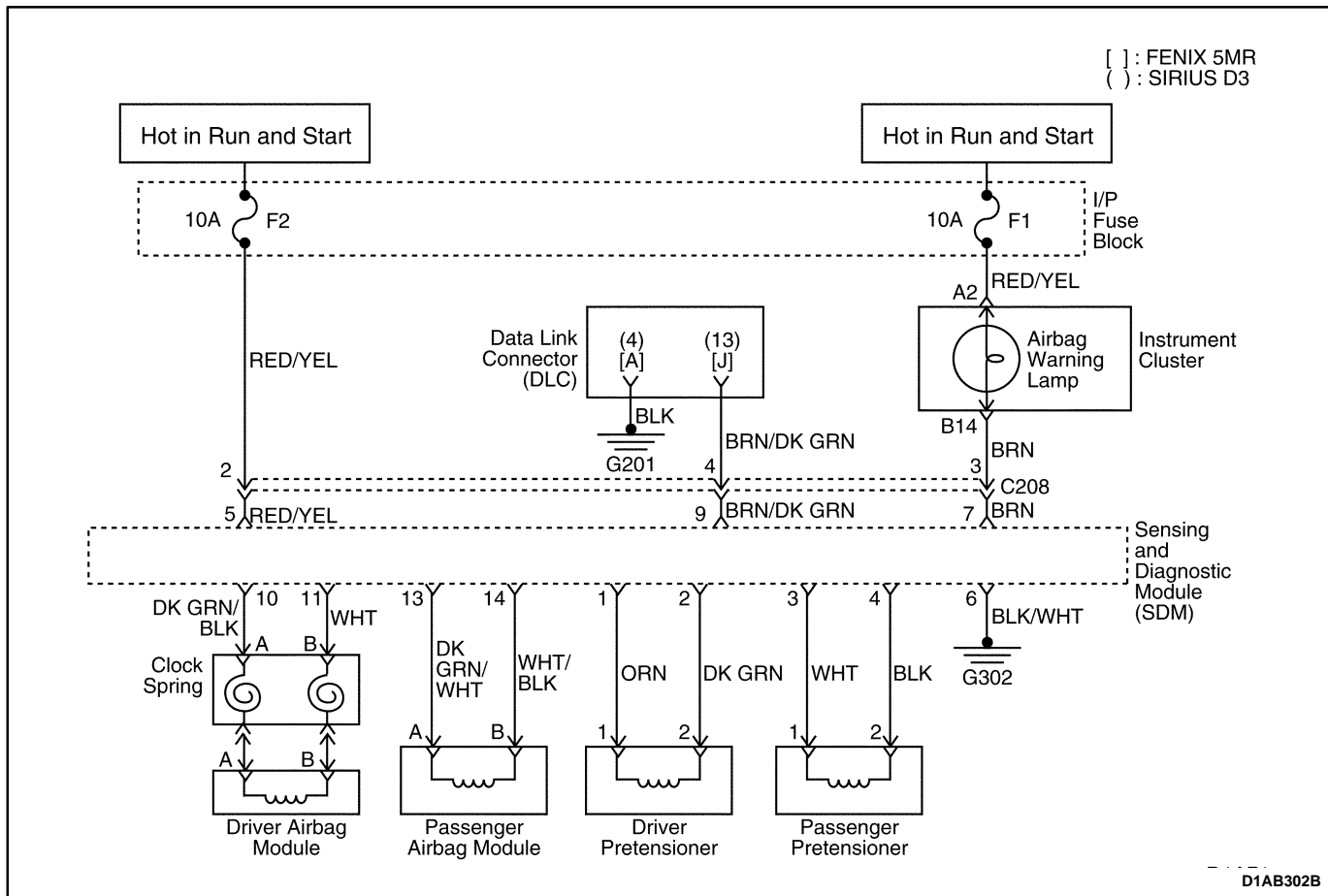

DIAGNOSTIC TROUBLE CODE (DTC) 16 PASSENGER PRETENSIONER CIRCUIT, SHORT TO BATTERY VOLTAGE

Circuit Description

When the ignition switch is turned ON, the sensing and diagnostic module (SDM) will perform tests to diagnose any malfunctions within itself.

After passing these tests, the SDM will check the passenger pretensioner circuit. The SDM allows a very small amount of current to flow through the circuit. The SDM monitors the voltage during this check.

DTC 16 Will Set When

- The firing circuit is shorted to the voltage.

Test Description

Caution: Before testing, disconnect the negative battery cable. Wait 1 minute for the SDM capacitor to discharge. The capacitor supplies the reserve power to deploy the airbags, even if the battery is disconnected. Unintentional deployment of the airbags can cause injury.

DTC 16 – Passenger Pretensioner Circuit, Short To Battery Voltage

Step	Action	Value(s)	Yes	No
1	1. Disconnect the battery negative cable. 2. Wait 1 minute for the SDM capacitor to discharge. <ul style="list-style-type: none"> The capacitor supplies reserve power to deploy the passenger seat belt pretensioner even if the battery has been disconnected. 3. Visually inspect the supplemental inflatable restraints (SIR) wiring harness. Is there any visible damage to the SIR wiring harness?	–	Go to <i>Step 2</i>	Go to <i>Step 3</i>
2	1. Replace the SIR wiring harness. 2. Reconnect the negative battery cable. Is the repair complete?	–	Go to <i>Diagnostic System Check</i>	–
3	1. Disconnect the electrical connector for the passenger seat belt pretensioner module. 2. Disconnect the electrical connector at the SDM. <ul style="list-style-type: none"> The shorting bar at the disconnected SDM connector will create a complete circuit between the wires from the passenger seat belt pretensioner module. 3. Use a multimeter to check the voltage at one of the terminals on the SDM side of the SIR wiring harness connector for the passenger seat belt pretensioner module. <ul style="list-style-type: none"> Refer to “Diagnostic Illustration 21” in this section. Is the voltage greater than the specified value?	0 v	Go to <i>Step 2</i>	Go to <i>Step 4</i>
4	1. Replace the SDM. 2. Reconnect the negative battery cable. 3. Set the scan tool to CODE ERASE. 4. Do the diagnostic system check. Does the code 16 still show as a current fault?	–	Go to <i>Step 5</i>	System OK
5	1. Replace the passenger seat belt pretensioner module. 2. Reconnect the negative battery cable. Is the repair complete?	–	Go to <i>Diagnostic System Check</i>	–

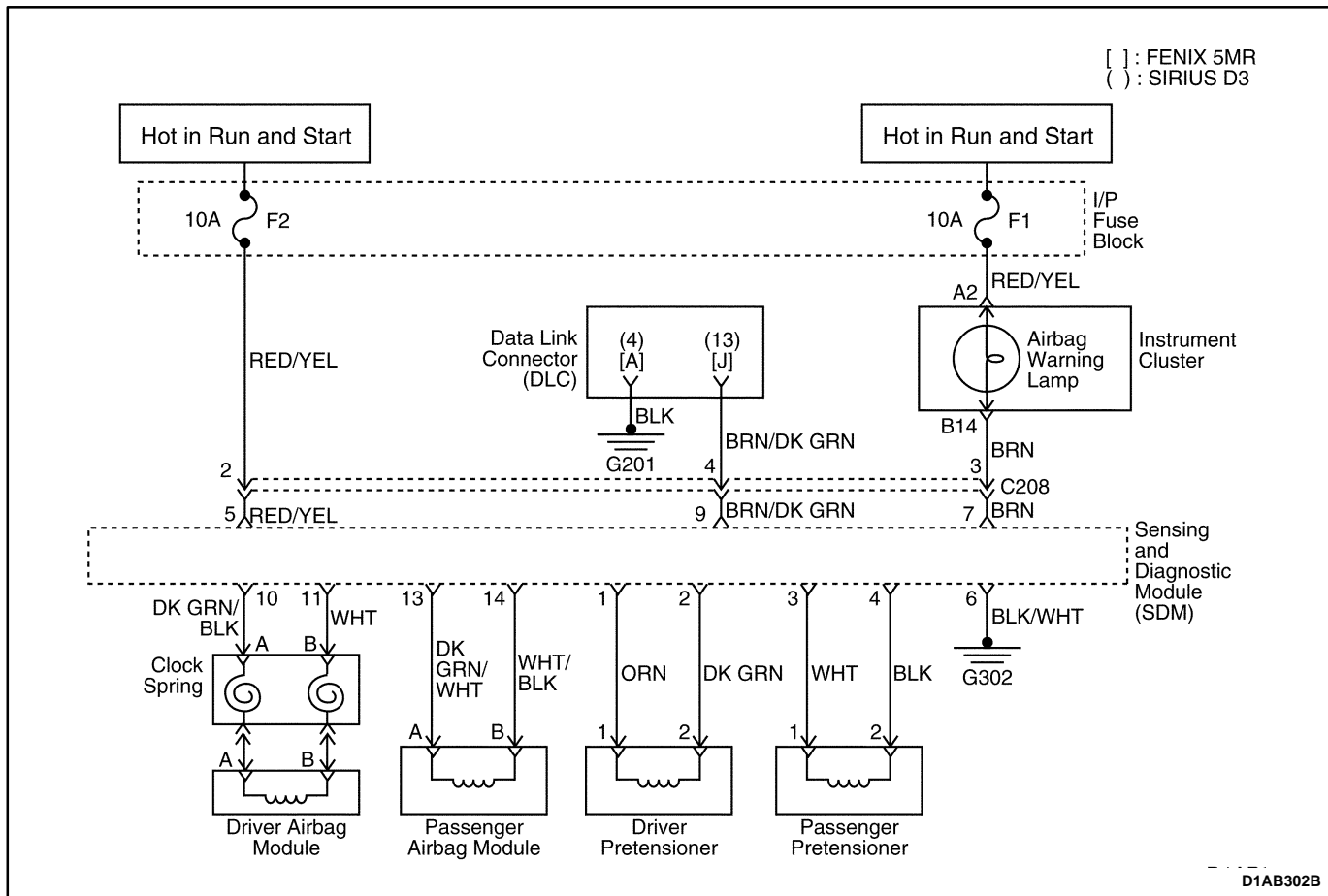

DIAGNOSTIC TROUBLE CODE (DTC) 18 CONNECTION BETWEEN DRIVER FIRING CIRCUIT AND DRIVER PRETENSIONER CIRCUIT

Open Circuit

Circuit Description

When the ignition switch is turned ON, the sensing and diagnostic module (SDM) will perform tests to diagnose any malfunctions within itself.

After passing these tests, the SDM will check the driver airbag and the driver pretensioner circuit. The SDM allows a very small amount of current to flow through the circuit. The SDM monitors the circuit resistance during this check.

DTC 18 Will Set When

- Connection between the driver firing circuit and the driver pretensioner circuit or the SDM internal connection problem may exist.

Test Description

Caution: Before testing, disconnect the negative battery cable. Wait 1 minute for the SDM capacitor to discharge. The capacitor supplies reserve power to deploy the airbags, even if the battery is disconnected. Unintentional deployment of the airbags can cause injury.

Caution: Never measure the resistance of an airbag module. If the anti-deployment shorting bar on the module-side of the connector is not working properly, the meter's battery can deploy the airbag and cause injury.

DTC 18 – Connection Between Driver Firing Circuit and Driver Pretensioner Circuit

Step	Action	Value(s)	Yes	No
1	1. Disconnect the negative battery cable. 2. Wait 1 minute for the SDM capacitor to discharge. 3. Examine the wiring and the connector at the driver side airbag module and the driver pretensioner module. Is the connector disconnected?	–	Go to <i>Step 2</i>	Go to <i>Step 3</i>
2	1. Reconnect the driver side airbag module and the driver pretensioner module. 2. Reconnect the negative battery cable. Is the repair complete?	–	Go to <i>Diagnostic System Check</i>	–
3	1. Disconnect the electrical connector for the driver side airbag module and the driver pretensioner module. 2. Disconnect the electrical connector at the SDM. <ul style="list-style-type: none"> ● The shorting bar at the disconnected SDM connector will create a complete circuit between the wires from the driver airbag module and the driver pretensioner module. 3. Connect an ohmmeter to the terminals on the SDM side of the wiring harness connector for the driver pretensioner module. <ul style="list-style-type: none"> ● Refer to “Diagnostic Illustration 16” in this section. Does the ohmmeter show the specified value?	≈ 0 Ω	Go to <i>Step 4</i>	Go to <i>Step 6</i>
4	1. Replace the SDM. 2. Reconnect the negative battery cable. 3. Set the scan tool for CODE ERASE. 4. Do the diagnostic system check. Does the code 18 still show as a current fault?	–	Go to <i>Step 5</i>	System OK
5	1. Replace the driver pretensioner module. 2. Reconnect the negative battery cable. Is the repair complete?	–	Go to <i>Diagnostic System Check</i>	–
6	1. Replace the supplemental inflatable restraints (SIR) wiring harness. 2. Reconnect the negative battery cable. Is the repair complete?	–	Go to <i>Diagnostic System Check</i>	–

DTC 19 – Connection Between Driver Firing Circuit and Passenger Pretensioner Circuit

Step	Action	Value(s)	Yes	No
1	1. Disconnect the negative battery cable. 2. Wait 1 minute for the SDM capacitor to discharge. 3. Examine the wiring and the connector at the driver side airbag module and the passenger pretensioner module. Is the connector disconnected?	–	Go to <i>Step 2</i>	Go to <i>Step 3</i>
2	1. Reconnect the driver side airbag module and the passenger pretensioner module connector. 2. Reconnect the negative battery cable. Is the repair complete?	–	Go to <i>Diagnostic System Check</i>	–
3	1. Disconnect the electrical connector for the driver side airbag module and the passenger pretensioner module. 2. Disconnect the electrical connector at the SDM. <ul style="list-style-type: none"> ● The shorting bar at the disconnected SDM connector will create a complete circuit between the wires from the driver airbag module and the passenger pretensioner module. 3. Connect an ohmmeter to the terminals on the SDM side of the wiring harness connector for the passenger pretensioner module. <ul style="list-style-type: none"> ● Refer to “Diagnostic Illustration 19” in this section. Does the ohmmeter show the specified value?	≈ 0 Ω	Go to <i>Step 4</i>	Go to <i>Step 6</i>
4	1. Replace the SDM. 2. Reconnect the negative battery cable. 3. Set the scan tool for CODE ERASE. 4. Do the diagnostic system check. Does the code 19 still show as a current fault?	–	Go to <i>Step 5</i>	System OK
5	1. Replace the passenger pretensioner module. 2. Reconnect the negative battery cable. Is the repair complete?	–	Go to <i>Diagnostic System Check</i>	–
6	1. Replace the supplemental inflatable restraints (SIR) wiring harness. 2. Reconnect the negative battery cable. Is the repair complete?	–	Go to <i>Diagnostic System Check</i>	–

DTC 20 – Connection Between Passenger Firing Circuit and Driver Pretensioner Circuit

Step	Action	Value(s)	Yes	No
1	1. Disconnect the negative battery cable. 2. Wait 1 minute for the SDM capacitor to discharge. 3. Examine the wiring and the connector at the passenger side airbag module and the driver pretensioner module. Is the connector disconnected?	–	Go to <i>Step 2</i>	Go to <i>Step 3</i>
2	1. Reconnect the passenger side airbag module and the driver pretensioner module connector. 2. Reconnect the negative battery cable. Is the repair complete?	–	Go to <i>Diagnostic System Check</i>	–
3	1. Disconnect the electrical connector for the passenger side airbag module and the driver pretensioner module. 2. Disconnect the electrical connector at the SDM. <ul style="list-style-type: none"> ● The shorting bar at the disconnected SDM connector will create a complete circuit between the wires from the passenger airbag module and the driver pretensioner module. 3. Connect an ohmmeter to the terminals on the SDM side of the wiring harness connector for the driver pretensioner module. <ul style="list-style-type: none"> ● Refer to “Diagnostic Illustration 16” in this section. Does the ohmmeter show the specified value?	≈ 0 Ω	Go to <i>Step 4</i>	Go to <i>Step 6</i>
4	1. Replace the SDM. 2. Reconnect the negative battery cable. 3. Set the scan tool for CODE ERASE. 4. Do the diagnostic system check. Does the code 20 still show as a current fault?	–	Go to <i>Step 5</i>	System OK
5	1. Replace the driver pretensioner module. 2. Reconnect the negative battery cable. Is the repair complete?	–	Go to <i>Diagnostic System Check</i>	–
6	1. Replace the supplemental inflatable restraints (SIR) wiring harness. 2. Reconnect the negative battery cable. Is the repair complete?	–	Go to <i>Diagnostic System Check</i>	–

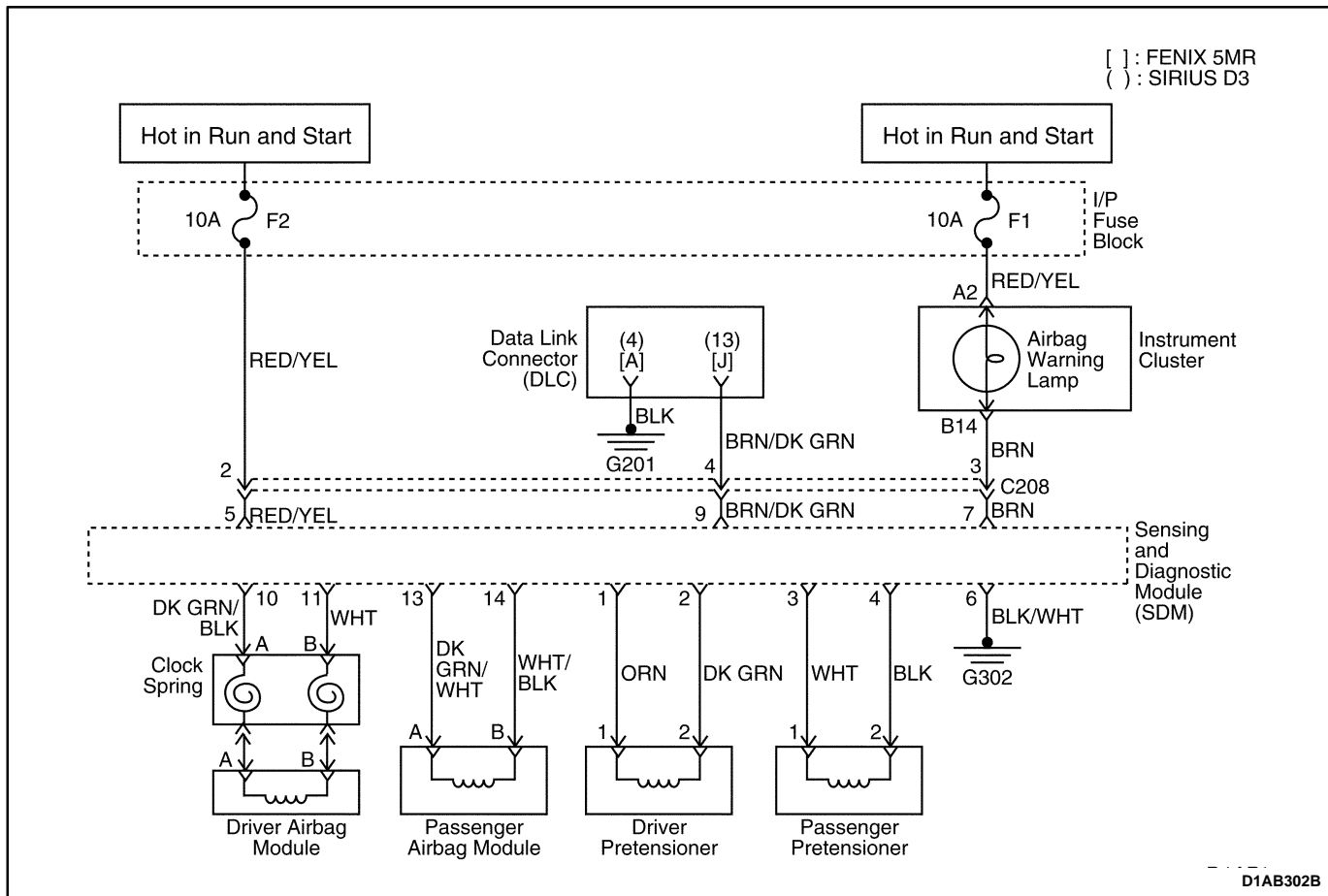

DIAGNOSTIC TROUBLE CODE (DTC) 21 CONNECTION BETWEEN PASSENGER FIRING CIRCUIT AND PASSENGER PRETENSIONER CIRCUIT

Open Circuit

Circuit Description

When the ignition switch is turned ON, the sensing and diagnostic module (SDM) will perform tests to diagnose any malfunctions within itself.

After passing these tests, the SDM will check the passenger airbag and the passenger circuit. The SDM allows a very small amount of current to flow through the circuit. The SDM monitors the circuit resistance during this check.

DTC 21 Will Set When

- Connection between the passenger firing circuit and the passenger pretensioner circuit or SDM internal connection problem may exist.

Test Description

Caution: Before testing, disconnect the negative battery cable. Wait 1 minute for the SDM capacitor to discharge. The capacitor supplies reserve power to deploy the airbags, even if the battery is disconnected. Unintentional deployment of the airbags can cause injury.

Caution: Never measure the resistance of an airbag module. If the anti-deployment shorting bar on the module-side of the connector is not working properly, the meter's battery can deploy the airbag and cause injury.

DTC 21 – Connection Between Passenger Firing Circuit and Passenger Pretensioner Circuit

Step	Action	Value(s)	Yes	No
1	1. Disconnect the negative battery cable. 2. Wait 1 minute for the SDM capacitor to discharge. 3. Examine the wiring and the connector at the passenger side airbag module and the passenger pretensioner module. Is the connector disconnected?	–	Go to <i>Step 2</i>	Go to <i>Step 3</i>
2	1. Reconnect the passenger side airbag module and the passenger pretensioner module connector. 2. Reconnect the negative battery cable. Is the repair complete?	–	Go to <i>Diagnostic System Check</i>	–
3	1. Disconnect the electrical connector for the passenger side airbag module and the passenger pretensioner module. 2. Disconnect the electrical connector at the SDM. <ul style="list-style-type: none"> ● The shorting bar at the disconnected SDM connector will create a complete circuit between the wires from the passenger airbag module and the passenger pretensioner module. 3. Connect an ohmmeter to the terminals on the SDM side of the wiring harness connector for the passenger pretensioner module. <ul style="list-style-type: none"> ● Refer to “Diagnostic Illustration 19” in this section. Does the ohmmeter show the specified value?	≈ 0 Ω	Go to <i>Step 4</i>	Go to <i>Step 6</i>
4	1. Replace the SDM. 2. Reconnect the negative battery cable. 3. Set the scan tool for CODE ERASE. 4. Do the diagnostic system check. Does the code 21 still show as a current fault?	–	Go to <i>Step 5</i>	System OK
5	1. Replace the passenger pretensioner module. 2. Reconnect the negative battery cable. Is the repair complete?	–	Go to <i>Diagnostic System Check</i>	–
6	1. Replace the supplemental inflatable restraints (SIR) wiring harness. 2. Reconnect the negative battery cable. Is the repair complete?	–	Go to <i>Diagnostic System Check</i>	–

DTC 22 – Connection Between Driver Pretensioner Circuit and Passenger Pretensioner Circuit

Step	Action	Value(s)	Yes	No
1	<ol style="list-style-type: none"> 1. Disconnect the negative battery cable. 2. Wait 1 minute for the SDM capacitor to discharge. 3. Examine the wiring and the connector at the driver pretensioner module and the passenger pretensioner module. Is the connector disconnected?	–	Go to Step 2	Go to Step 3
2	<ol style="list-style-type: none"> 1. Reconnect the driver pretensioner module and the passenger pretensioner module connector. 2. Reconnect the negative battery cable. Is the repair complete?	–	Go to Diagnostic System Check	–
3	<ol style="list-style-type: none"> 1. Disconnect the electrical connector for the driver pretensioner module and the passenger passenger module. 2. Disconnect the electrical connector at the SDM. <ul style="list-style-type: none"> • The shorting bar at the disconnected SDM connector will create a complete circuit between the wires from the driver pretensioner module and the passenger pretensioner module. 3. Connect an ohmmeter to the terminals on the SDM side of the wiring harness connector for the driver pretensioner module. <ul style="list-style-type: none"> • Refer to “Diagnostic Illustration 16” in this section. Does the ohmmeter show the specified value?	≈ 0 Ω	Go to Step 4	Go to Step 7
4	<ol style="list-style-type: none"> 1. Disconnect the electrical connector for the driver pretensioner module and the passenger passenger module. 2. Disconnect the electrical connector at the SDM. <ul style="list-style-type: none"> • The shorting bar at the disconnected SDM connector will create a complete circuit between the wires from the driver pretensioner module and the passenger pretensioner module. 3. Connect an ohmmeter to the terminals on the SDM side of the wiring harness connector for the passenger pretensioner module. <ul style="list-style-type: none"> • Refer to “Diagnostic Illustration 19” in this section. Does the ohmmeter show the specified value?	≈ 0 Ω	Go to Step 5	Go to Step 7
5	<ol style="list-style-type: none"> 1. Replace the SDM. 2. Reconnect the negative battery cable. 3. Set the scan tool for CODE ERASE. 4. Do the diagnostic system check. Does the code 22 still show as a current fault?	–	Go to Step 6	System OK
6	<ol style="list-style-type: none"> 1. Replace the passenger side airbag module. 2. Reconnect the negative battery cable. Is the repair complete?	–	Go to Diagnostic System Check	–
7	<ol style="list-style-type: none"> 1. Replace the supplemental inflatable restraints (SIR) wiring harness. 2. Reconnect the negative battery cable. Is the repair complete?	–	Go to Diagnostic System Check	–

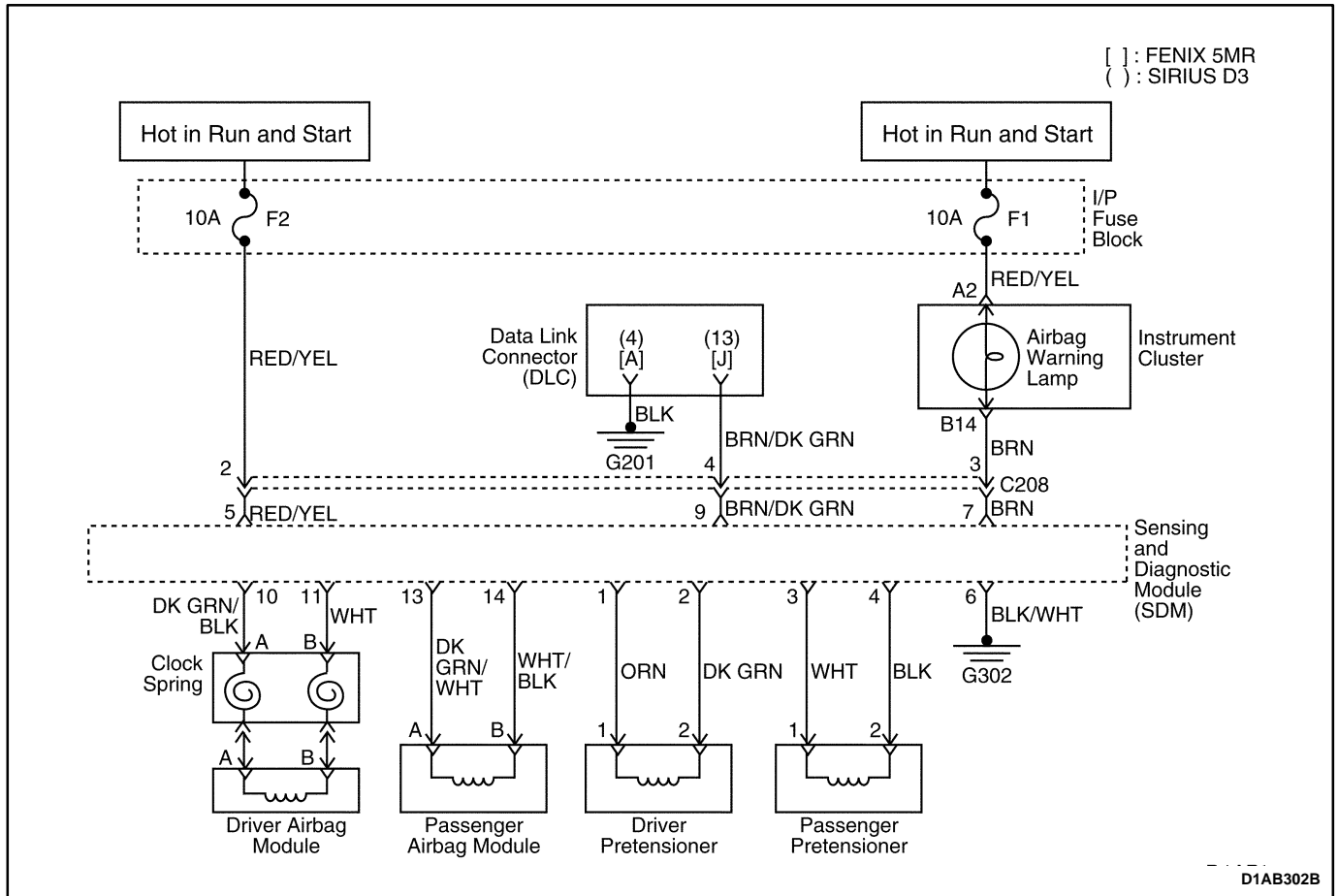

DIAGNOSTIC TROUBLE CODE (DTC) 23 IGNITION INPUT CIRCUIT, VOLTAGE TOO HIGH

Circuit Description

When the ignition switch is turned ON, the sensing and diagnostic module (SDM) will perform tests to diagnose any malfunctions within itself.

After completing the internal tests, the SDM will check its voltage supply. If the voltage supply is too high or too low, the SDM may not receive the proper information when it attempts to use a known current to test the airbag module circuits.

DTC 23 Will Set When

- The SDM receives voltage higher than a specified value.

Test Description

Caution: Before testing, disconnect the negative battery cable. Wait 1 minute for the SDM capacitor to discharge. The capacitor supplies reserve power to deploy the airbags, even if the battery is disconnected. Unintentional deployment of the airbags can cause injury.

DTC 23 – Ignition Input Circuit, Voltage Too High

Step	Action	Value(s)	Yes	No
1	Check the vehicle's charging system. Refer to <i>Section 1E, Engine Electrical</i> . Is the charging system OK?	–	Go to <i>Step 3</i>	Go to <i>Step 2</i>
2	Repair the charging system. Is the repair complete?	–	Go to <i>Diagnostic System Check</i>	–
3	1. Disconnect the negative battery cable. 2. Replace the SDM. Is the repair complete?	–	Go to <i>Diagnostic System Check</i>	–

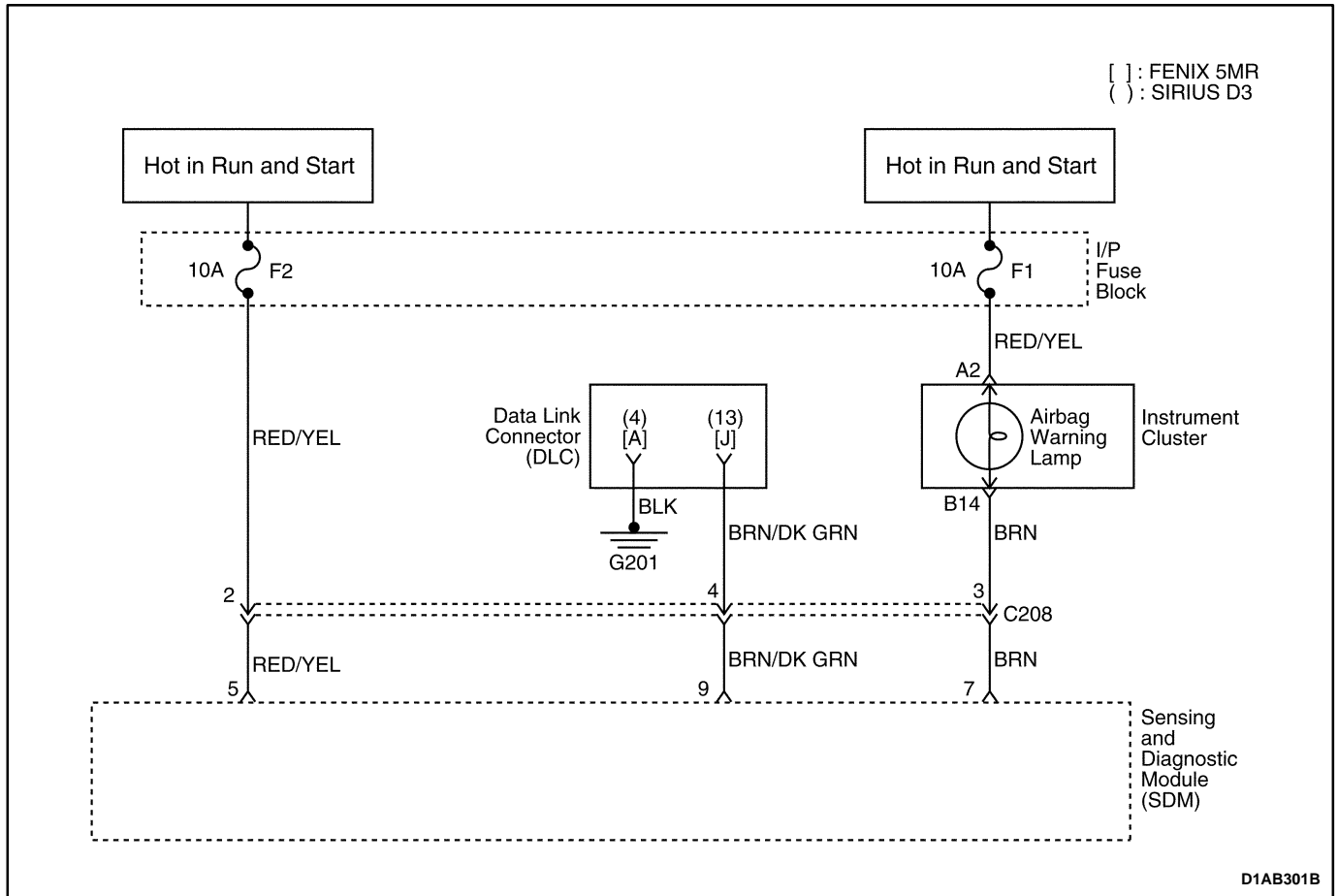

DIAGNOSTIC TROUBLE CODE (DTC) 24 IGNITION INPUT CIRCUIT, VOLTAGE TOO LOW

Circuit Description

When the ignition switch is turned ON, the sensing and diagnostic module (SDM) will perform tests to diagnose any malfunctions within itself.

After completing the internal tests, the SDM will check its voltage supply. If the voltage supply is too high or too low, the SDM may not receive the proper information when it attempts to use a known current to test the airbag module circuits.

DTC 24 Will Set When

- The SDM receives the voltage lower than a specified value.

Test Description

Caution: Before testing, disconnect the negative battery cable. Wait 1 minute for the SDM capacitor to discharge. The capacitor supplies reserve power to deploy the airbags, even if the battery is disconnected. Unintentional deployment of the airbags can cause injury.

Caution: As a safety precaution, disconnect the connector for the passenger airbag module. Unintentional deployment of the airbags can cause injury.

DTC 24 – Ignition Input Circuit, Voltage Too Low

Step	Action	Value(s)	Yes	No
1	Check the fuse F2. Is the fuse blown?	–	Go to <i>Step 2</i>	Go to <i>Step 3</i>
2	1. Check for a short circuit. 2. Repair if needed. 3. Replace the fuse. Is the repair complete?	–	Go to <i>Diagnostic System Check</i>	–
3	1. Turn the ignition ON. 2. Using a multimeter, check the voltage at the fuse F2. Is the battery voltage available at the fuse F2?	11–14 v	Go to <i>Step 5</i>	Go to <i>Step 4</i>
4	Repair the power supply to the fuse F2. Is the repair complete?	–	Go to <i>Diagnostic System Check</i>	–
5	1. Disconnect the negative battery cable. 2. Wait one minute before proceeding. 3. Disconnect the connector at the SDM. 4. Reconnect the battery. 5. Turn the ignition key ON. 6. Measure the voltage at the terminal 5 of the SDM Connector. • Refer to “Diagnostic Illustration 11” in this section. Is the voltage equal to the specified value?	11–14 v	Go to <i>Step 6</i>	Go to <i>Step 7</i>
6	1. Replace the SDM. 2. Reconnect the electrical connectors. Is the repair complete?	–	Go to <i>Diagnostic System Check</i>	–
7	1. Disconnect the connector C208. • The connector C208 is the connector between the instrument harness and the supplemental inflatable restraints (SIR) harness. 2. Turn the ignition ON. 3. Using a multimeter, check the voltage on the instrument harness side at the terminal 2 of the connector C208. • Refer to “Diagnostic Illustration 12” in this section. Is the voltage equal to the specified value?	11–14 v	Go to <i>Step 8</i>	Go to <i>Step 9</i>
8	1. Replace the SIR wiring harness. 2. Reconnect the battery. Is the repair complete?	–	Go to <i>Diagnostic System Check</i>	–
9	Repair the open circuit between the fuse F2 and the connector C208. Is the repair complete?	–	Go to <i>Diagnostic System Check</i>	–

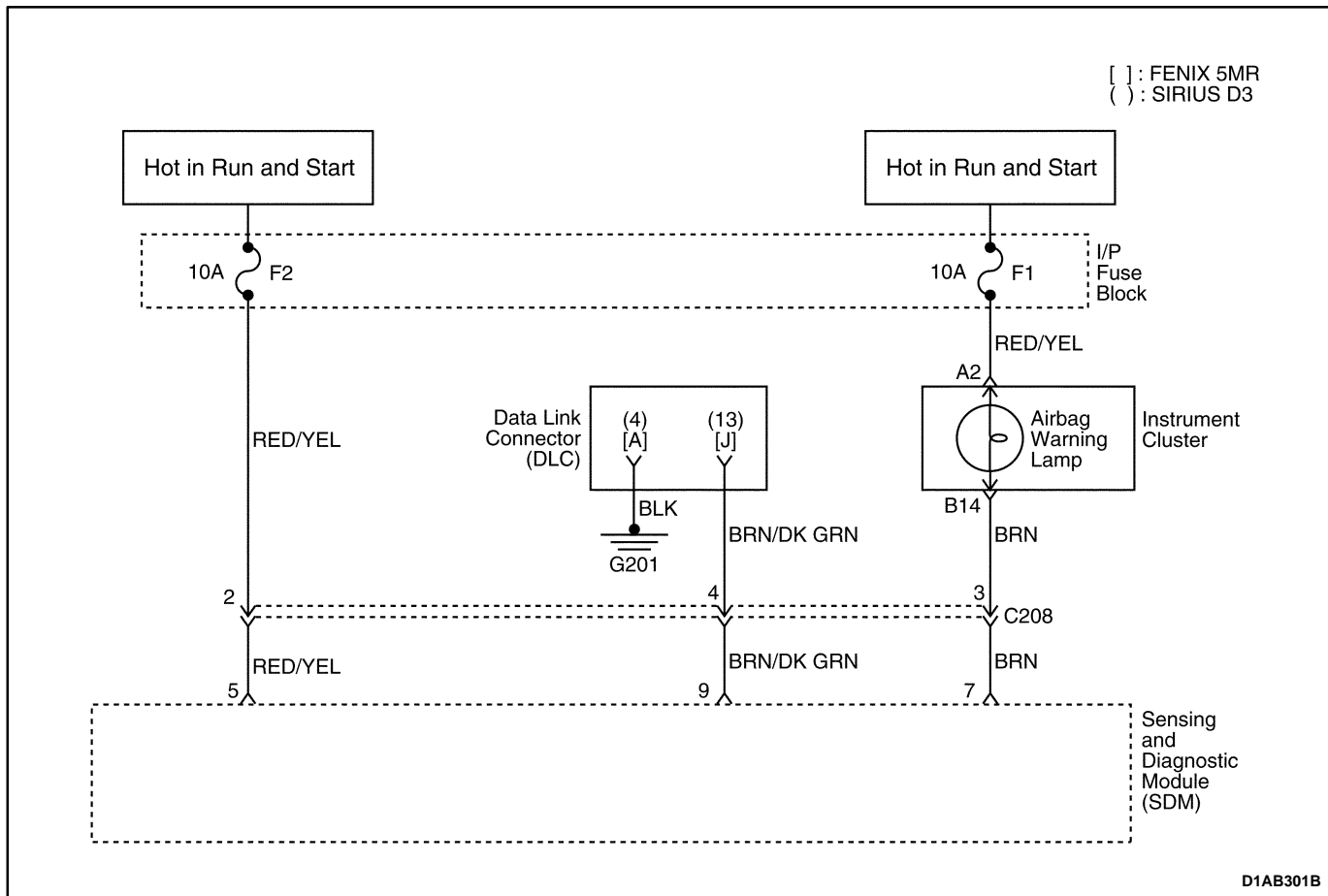

DIAGNOSTIC TROUBLE CODE (DTC) 25 WARNING LAMP FAILURE

Circuit Description

When the ignition switch is turned ON, the sensing and diagnostic module (SDM) will perform tests to diagnose any malfunctions within itself.

After passing these tests, the SDM will check the warning lamp circuit. The SDM constantly measures the voltage at the warning lamp output in order to determine if the lamp is ON or OFF at the correct time.

DTC 25 Will Set When

- The lamp is ON when it should be OFF.
- The lamp is OFF when it should be ON.

Diagnostic Aids

When the warning lamp operates correctly, the warning lamp turns ON for approximately four seconds after the ignition is first switched ON, and then The warning lamp turns OFF.

When the warning lamp operates incorrectly, the warning lamp continues to blink four times per second, demonstrating that the SDM is faulty and must be replaced.

Test Description

Caution: Before testing, disconnect the negative battery cable. Wait 1 minute for the SDM capacitor to discharge. The capacitor supplies reserve power to deploy the airbags, even if the battery is disconnected. Unintentional deployment of the airbags can cause injury.

Caution: If the short is in the supplemental inflatable restraints (SIR) wiring harness, do not attempt to repair it. The repair might create a high-resistance connection which can keep the airbags from deploying when needed, resulting in injury. Replace the SIR wiring harness if it is damaged.

DTC 25 – Warning Lamp Failure

Step	Action	Value(s)	Yes	No
1	Turn the ignition ON. Is the warning lamp constantly ON?	–	Go to <i>Step 2</i>	Go to <i>Step 9</i>
2	Make sure the SDM connector is attached correctly. Does the warning lamp turn OFF?	–	Go to <i>Diagnostic System Check</i>	Go to <i>Step 3</i>
3	1. Check for indications of the diagnostic trouble code (DTC) other than the code 25. 2. Go to the appropriate DTC charts and repair each additional problem. 3. Do the diagnostic system check. Does the scan tool still indicate the code 25?	–	Go to <i>Step 4</i>	System OK
4	Check for a short to ground between the SDM and the warning lamp using the following method: 1. Turn the ignition OFF. 2. Disconnect the connector C208. 3. Connect one ohmmeter lead to ground. 4. Touch the other ohmmeter lead to the terminal 3 of the connector C208 on the instrument harness side. ● Refer to “Diagnostic Illustration 14” in this section. Does the ohmmeter indicate the specified value?	∞	Go to <i>Step 6</i>	Go to <i>Step 5</i>
5	Repair the short to ground in the instrument harness. Is the repair complete?	–	Go to <i>Diagnostic System Check</i>	–
6	1. The connector C208 remains disconnected. 2. One lead of the ohmmeter remains connected to ground. 3. Move the ohmmeter lead at the connector C208 to the SDM side of the connector. ● Refer to “Diagnostic Illustration 13” in this section. Does the ohmmeter indicate the specified value?	∞	Go to <i>Step 7</i>	Go to <i>Step 8</i>
7	Replace the SDM. Is the repair complete?	–	Go to <i>Diagnostic System Check</i>	–
8	1. Disconnect the negative battery cable. 2. Replace the SIR wiring harness. 3. Do the diagnostic system check. Does the code 25 still show?	–	Go to <i>Step 5</i>	System OK
9	Check the fuse F1. Is the fuse F1 blown?	–	Go to <i>Step 10</i>	Go to <i>Step 11</i>
10	1. With the connector C208 temporarily disconnected, check for a short to ground between the fuse F1 and the warning lamp. 2. Make a repair, if needed. 3. Replace the fuse F1. Is the repair complete?	–	Go to <i>Diagnostic System Check</i>	–

DTC 25 – Warning Lamp Failure (Cont'd)

Step	Action	Value(s)	Yes	No
11	1. Turn the ignition ON. 2. Using a multimeter, check the voltage at the fuse F1. Does the multimeter show the specified value?	11–14 v	Go to <i>Step 13</i>	Go to <i>Step 12</i>
12	Repair the open power supply circuit for the fuse F1. Is the repair complete?	–	Go to <i>Diagnostic System Check</i>	–
13	1. Disconnect the connector C208. 2. Turn the ignition ON. 3. Using a multimeter, check the voltage on the instrument harness side of the terminal 3 of the connector C208. Does the multimeter show the specified value?	11–14 v	Go to <i>Step 15</i>	Go to <i>Step 14</i>
14	1. Check the warning lamp bulb. 2. Replace the warning lamp bulb, if needed. 3. If the bulb is good, repair the open circuit between the fuse F1 and the terminal 3 of the connector C208. Is the repair complete?	–	Go to <i>Diagnostic System Check</i>	–
15	1. Disconnect the negative battery terminal. 2. Wait at least 1 minute before proceeding. 3. Replace the SIR wiring harness. Is the repair complete?	–	System OK	–

DIAGNOSTIC TROUBLE CODE (DTC) 31 SDM INTERNAL FAULT

Circuit Description

When the ignition switch is turned ON, the sensing and diagnostic module (SDM) will perform tests to diagnose malfunctions within itself.

DTC 31 Will Set When

- The SDM does not pass the internal tests.

Test Description

Caution: Before testing, disconnect the negative battery cable. Wait 1 minute for the SDM capacitor to discharge. The capacitor supplies reserve power to deploy the airbags, even if the battery is disconnected. Unintentional deployment of the airbags can cause injury.

DTC 31 – SDM Internal Fault

Step	Action	Value(s)	Yes	No
1	1. Disconnect the negative battery cable. 2. Replace the SDM. Is the repair complete?	-	Go to Diagnostic System Check	-

DIAGNOSTIC TROUBLE CODE (DTC) 32 SDM CRASH RECORDED

Circuit Description

When the ignition switch is turned ON, the sensing and diagnostic module (SDM) will perform tests to diagnose any malfunctions within itself.

DTC 32 Will Set When

- The SDM has previously detected a crash.

Test Description

Caution: Before testing, disconnect the negative battery cable. Wait 1 minute for the SDM capacitor to discharge. The capacitor supplies reserve power to deploy the airbags, even if the battery is disconnected. Unintentional deployment of the airbags can cause injury.

DTC 32 – SDM Crash Recorded

Step	Action	Value(s)	Yes	No
1	1. Disconnect the negative battery cable. 2. Replace the SDM. Is the repair complete?	-	Go to Diagnostic System Check	-

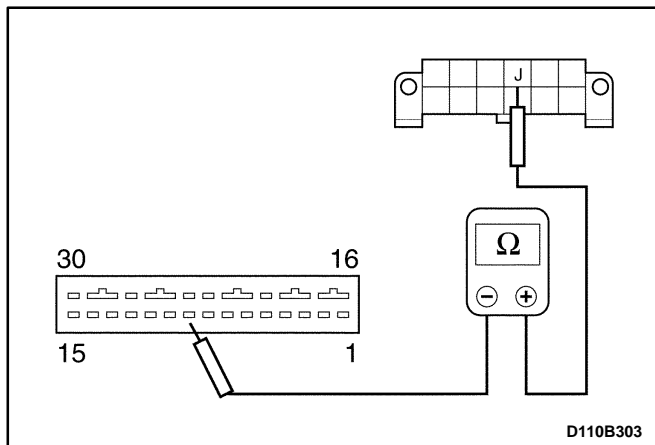

Caution: Do not use these illustrations to troubleshoot without consulting the diagnostic trouble code (DTC) charts. The DTC charts give additional safety precautions and detailed instructions for each test. Failure to follow the proper precautions can result in injury from unintended airbag deployment.

DIAGNOSTIC ILLUSTRATION 1

Checking the continuity between the terminal 9 of the sensing and diagnostic module and the terminal J (13) of the assembly line diagnostic link.

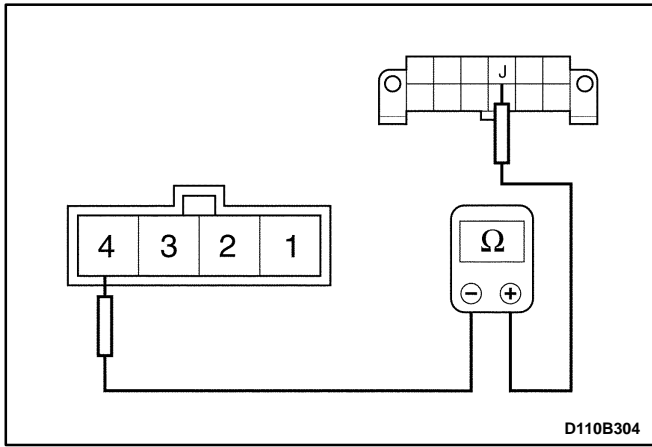

DIAGNOSTIC ILLUSTRATION 2

Checking the continuity on the instrument harness side between the terminal J (13) of the assembly line diagnostic link and the terminal 4 of the connector C208.

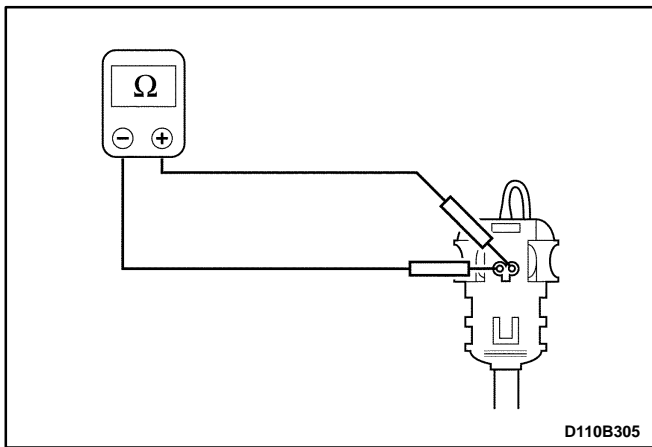

DIAGNOSTIC ILLUSTRATION 3

Measuring the wiring harness for the continuity of the driver side airbag module circuit.

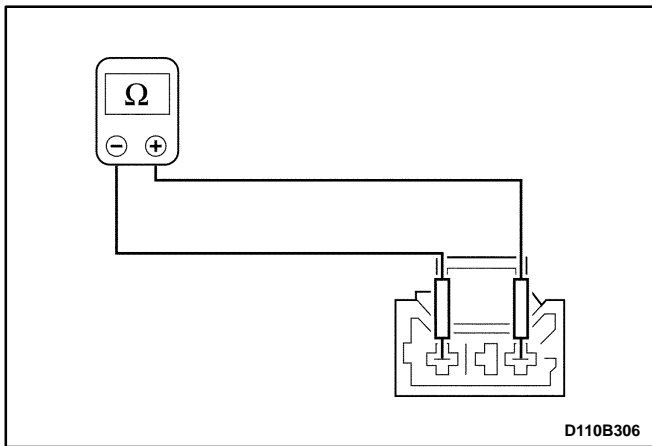

DIAGNOSTIC ILLUSTRATION 4

Checking the continuity of the driver airbag circuit on the sensing and diagnostic module (SDM) side of the clock spring connector.

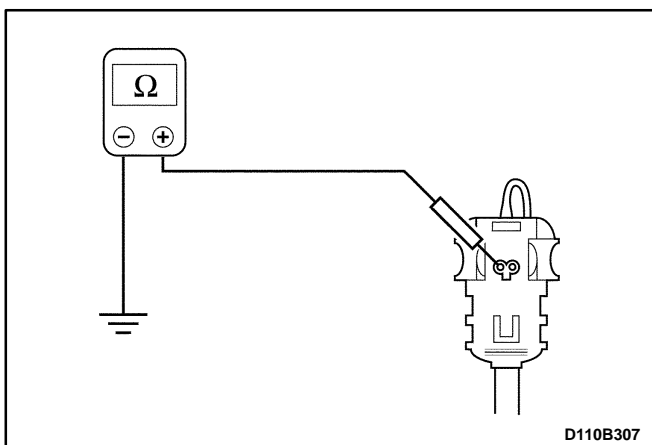

DIAGNOSTIC ILLUSTRATION 5

Checking the driver airbag circuit for a short to ground with the sensing and diagnostic module disconnected.

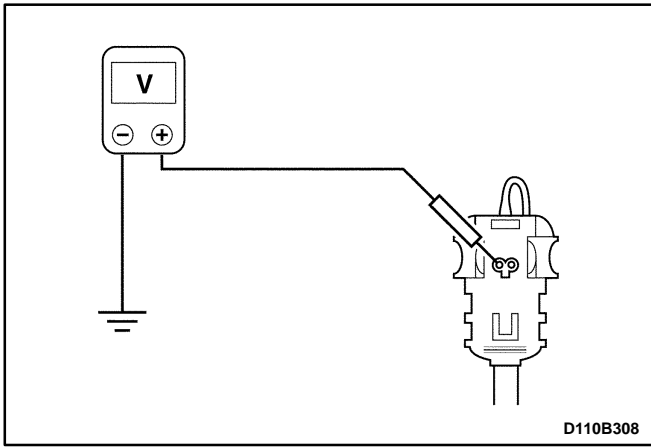

DIAGNOSTIC ILLUSTRATION 6

Checking the driver airbag circuit for a short to voltage.

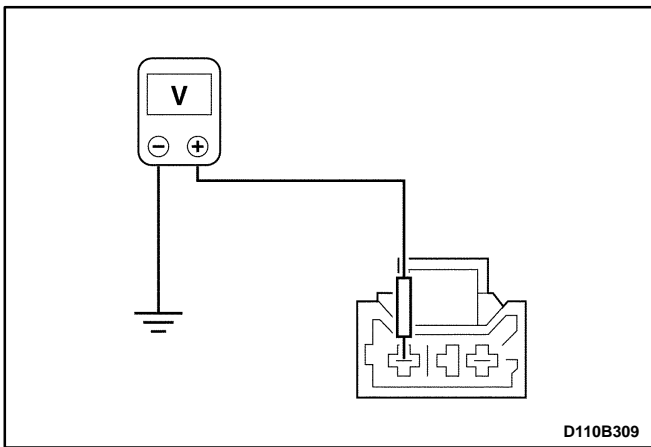

DIAGNOSTIC ILLUSTRATION 7

Checking the clock spring connector for a short to voltage on the sensing and diagnostic module side.

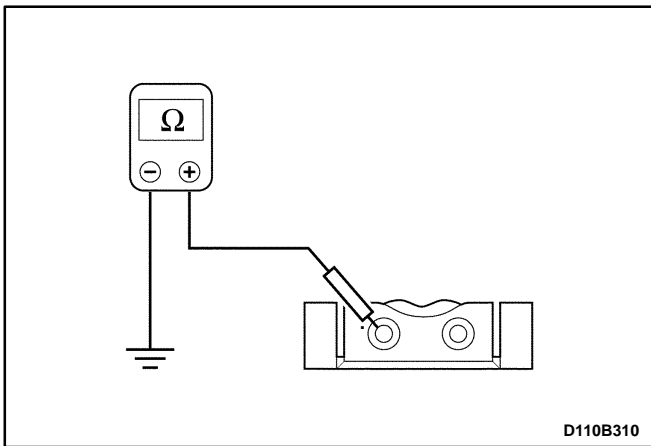

DIAGNOSTIC ILLUSTRATION 8

Checking the passenger airbag circuit continuity on the sensing and diagnostic module side of the connector.

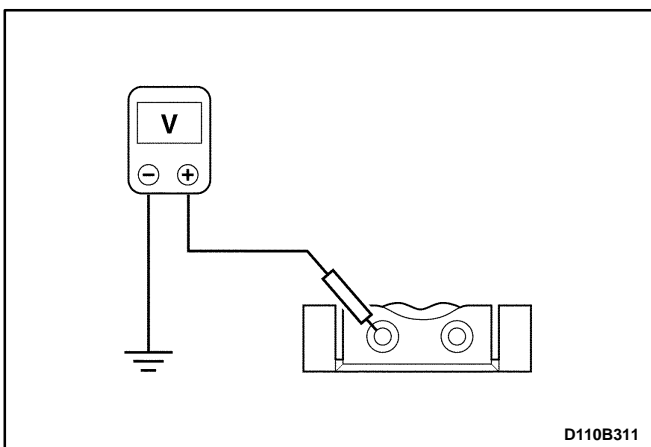

DIAGNOSTIC ILLUSTRATION 9

Checking the passenger airbag circuit for a short to ground.

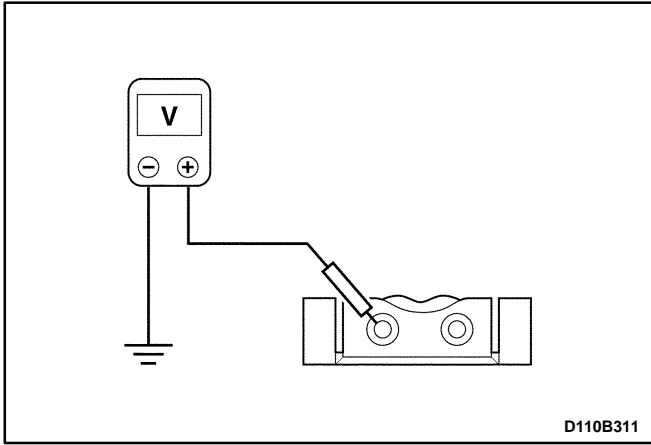

DIAGNOSTIC ILLUSTRATION 10

Checking the passenger airbag circuit for a short to voltage.

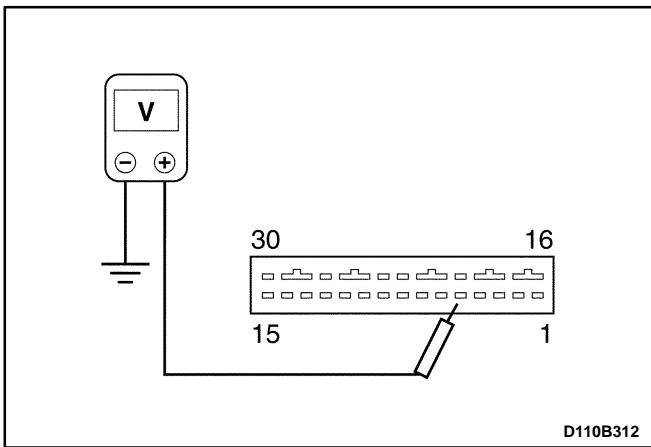

DIAGNOSTIC ILLUSTRATION 11

Checking the sensing and diagnostic module voltage supply at the terminal 5.

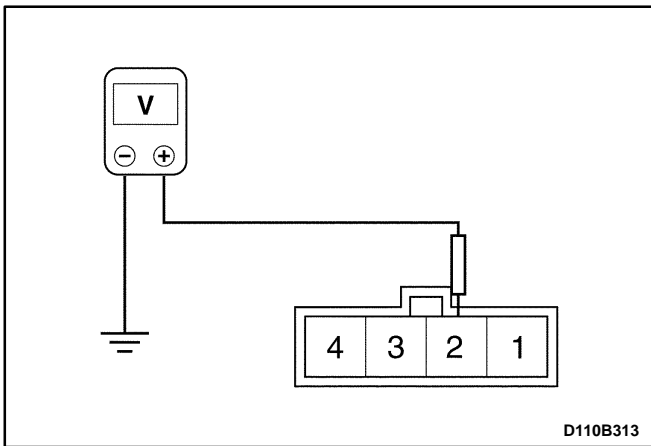

DIAGNOSTIC ILLUSTRATION 12

Checking the voltage supply on the instrument harness side at the terminal 2 of the connector C208.

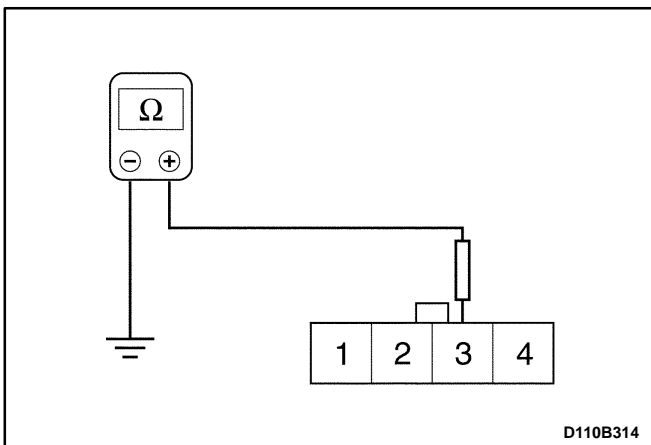

DIAGNOSTIC ILLUSTRATION 13

Checking for a short to ground on the sensing and diagnostic module side of the supplemental inflatable restraints harness at the terminal 3 of the connector C208.

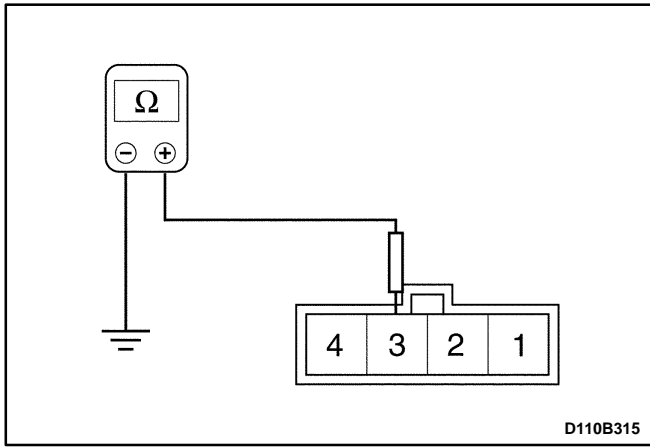

DIAGNOSTIC ILLUSTRATION 14

Checking for a short to ground in the instrument harness on the instrument harness side at the terminal 3 of the connector C208.

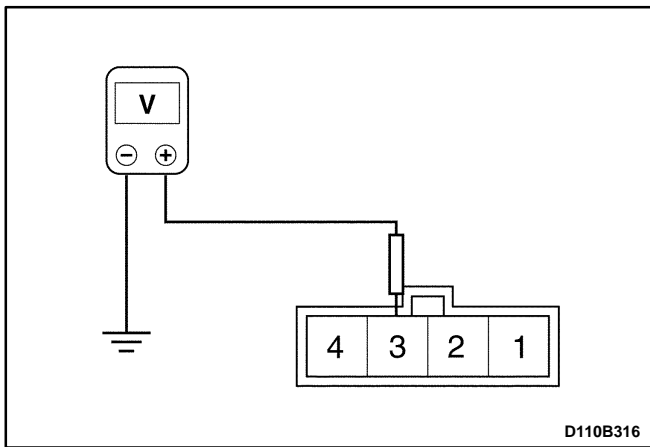

DIAGNOSTIC ILLUSTRATION 15

Checking the voltage of the warning lamp circuit on the instrument harness side at the terminal 3 of the connector C208.

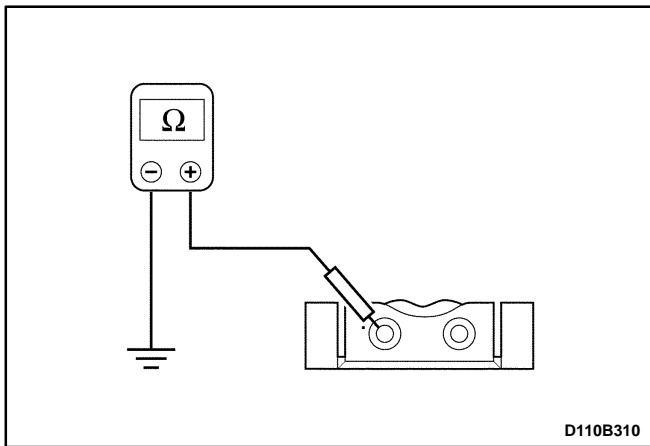

DIAGNOSTIC ILLUSTRATION 16

Checking the driver seat belt pretensioner circuit continuity on the sensing and diagnostic module side of the connector.

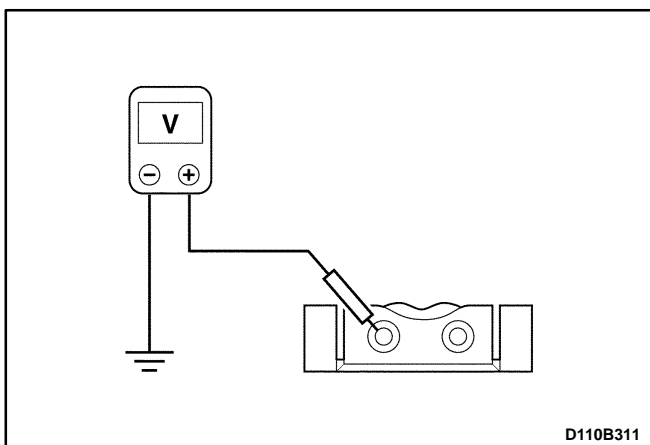

DIAGNOSTIC ILLUSTRATION 17

Checking the driver seat belt pretensioner circuit for a short to ground.

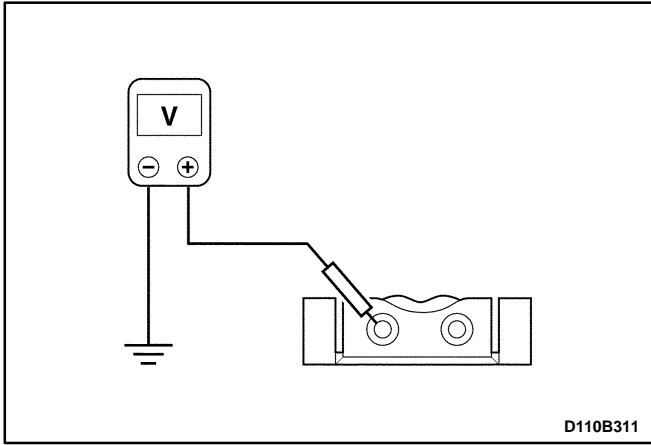

DIAGNOSTIC ILLUSTRATION 18

Checking the driver seat belt pretensioner circuit for a short to voltage.

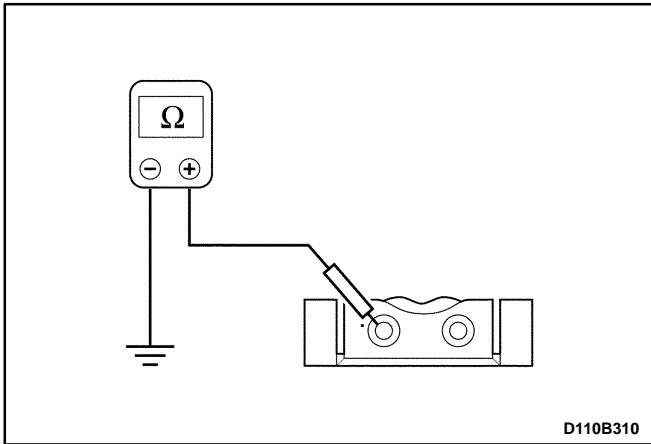

DIAGNOSTIC ILLUSTRATION 19

Checking the passenger seat belt pretensioner circuit continuity on the sensing and diagnostic module side of the connector.

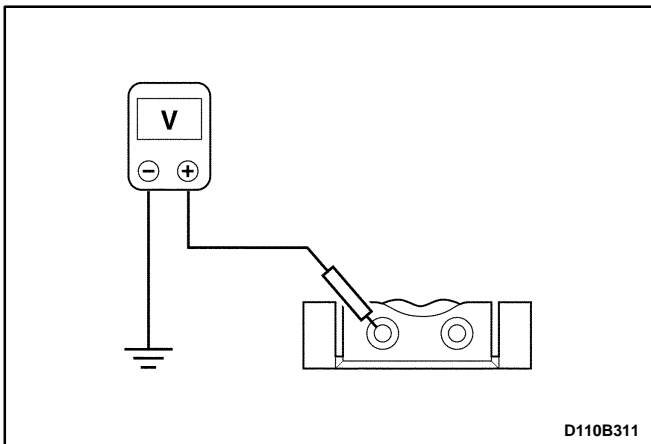

DIAGNOSTIC ILLUSTRATION 20

Checking the passenger seat belt pretensioner circuit for a short to ground.

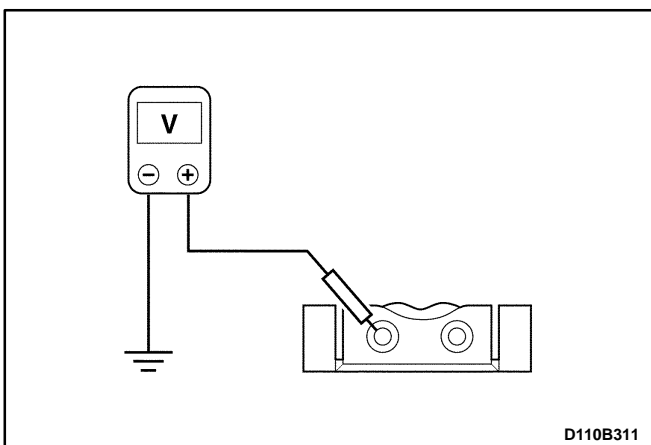

DIAGNOSTIC ILLUSTRATION 21

Checking the passenger seat belt pretensioner circuit for a short to voltage.

REPAIR INSTRUCTIONS

ON-VEHICLE SERVICE

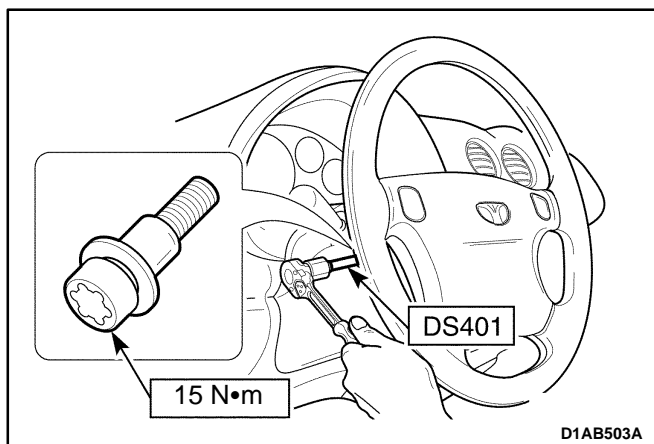
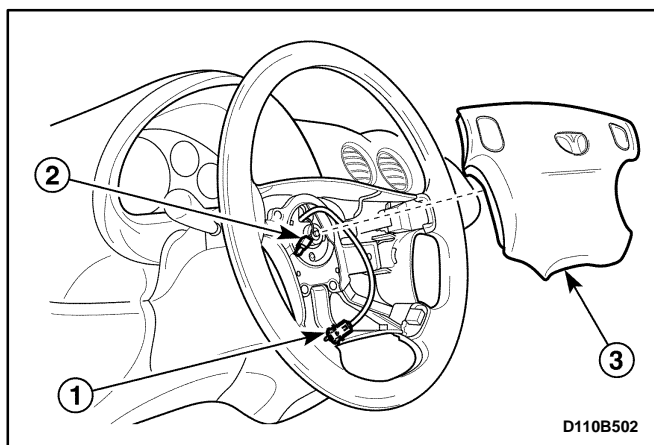
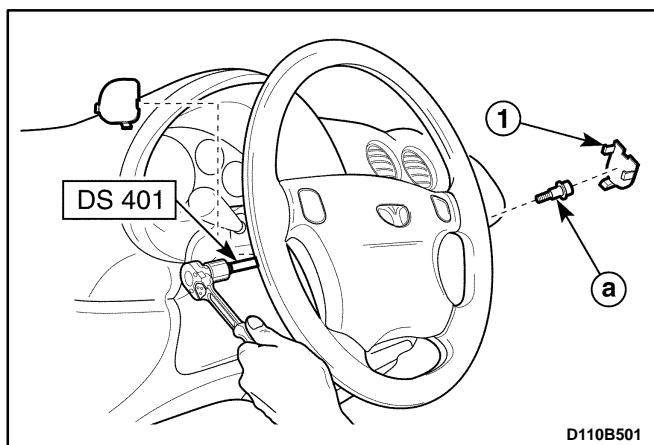

DRIVER AIRBAG MODULE

(Left-Hand Drive Shown, Right-Hand Drive Similar)

Tool Required

DS 401 Torx Bolt Wrench

Removal Procedure

1. Disconnect the negative battery cable.
2. Position the steering wheel straight ahead.
3. Remove the driver airbag module mounting bolts.
 - Remove the airbag module bolt cover (1).
 - Remove the airbag module torx bolt using a torx bolt wrench DS 401.
 - a. Airbag module torx bolt.

Caution: When handling an airbag module, always keep the top of the unit facing upward. This leaves room for the module to expand if the module unexpectedly deploys. Without room for expansion, a module suddenly propelled toward a person or object can cause injury or vehicle damage.

4. Remove the driver airbag module.
 - Disconnect the driver airbag module connector (1).
 - Disconnect the horn terminal connector (2).
 - Remove the driver airbag module (3).

Installation Procedure

Caution: When removing an airbag module or handling a new airbag module, always keep the top of the unit facing upward. This leaves room for the module to expand if the module unexpectedly deploys. Without room for expansion, a module suddenly propelled toward a person or object can cause injury or vehicle damage.

1. Install the driver airbag module.
2. Connect the connectors to the horn terminal and the driver airbag module.
3. Install the driver airbag module torx bolt using a torx bolt wrench DS 401.

Tighten

Tighten the torx bolt to 15 N•m (11 lb-ft)

4. Connect the negative battery cable.

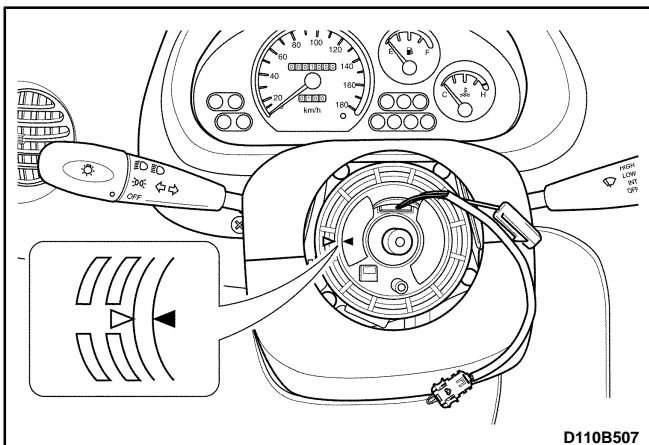
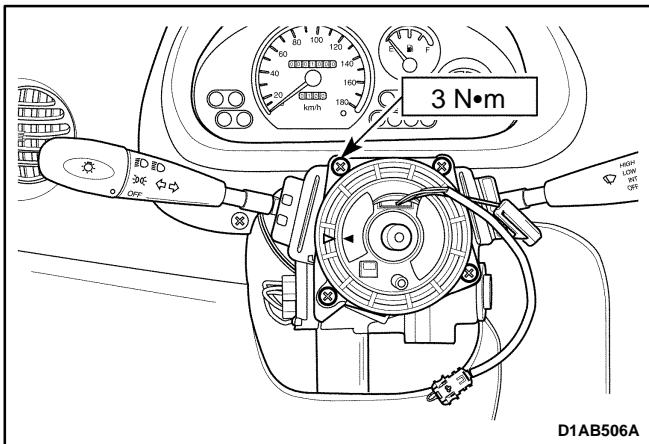
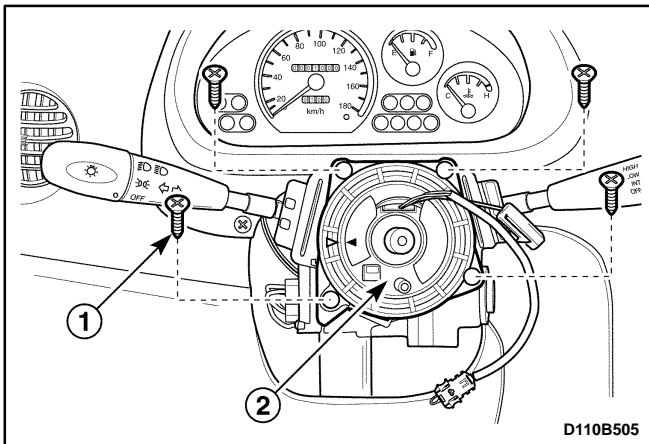
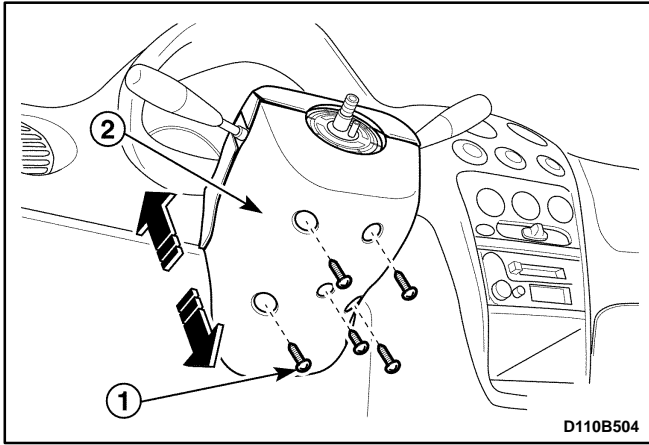

CLOCK SPRING

(Left-Hand Drive Shown, Right-Hand Drive Similar)

Removal Procedure

1. Disconnect the negative battery cable. Wait 1 minute until the capacitor inside the sensing and diagnostic module has discharged.
2. Remove the driver airbag module. Refer to "Driver Airbag Module" in this section.
3. Remove the steering wheel. Refer to *Section 6E, Steering Wheel and Column*.
4. Remove the lower/upper steering column cover.
 - Remove the screws (1).
 - Remove the lower/upper steering column cover(2).
5. Disconnect the clock spring and the horn terminal connector.
6. Disconnect the clock spring and the horn terminal connector which are banded on the steering column.
7. Remove the clock spring.
 - Remove the screws (1).
 - Remove the clock spring (2).

Installation Procedure

Caution: If the clock spring is not properly aligned, the steering wheel may not be able to rotate completely during a turn. Restricted turning ability can cause the vehicle to crash. Improper alignment of the clock spring also may make the supplemental inflatable restraints (SIR) system inoperative, preventing the airbags from deploying during a crash. Both of these outcomes can result in injury.

Notice: Turning the clock spring more than three turns clockwise or more than three turns counterclockwise can damage the spring.

1. Turn the front wheels straight ahead.
2. Install the clock spring with the screws.

Tighten

Tighten the clock spring mounting screws to 3 N•m (27 lb-in)

Important: The clock spring may come packed in material used to prevent damage to the spring during shipping or storage. Avoid installing any of the packing material with the clock spring.

3. Turn the label of the clock spring clockwise to lock.
4. Turn the label of the clock spring counterclockwise approximately three turns to the neutral positions with the front wheels ahead.

5. Properly align the pointed marks (▷◀) on the components of the clock spring.
6. Connect the electrical connectors on the lower steering column.
7. Install the lower/upper steering column cover.
8. Install the steering wheel. Refer to *Section 6E, Steering Wheel and Column*.
9. Connect the driver airbag module and the horn connectors.
10. Install the driver airbag module. Refer to "Driver airbag module" in this section.
11. Connect the negative battery cable.

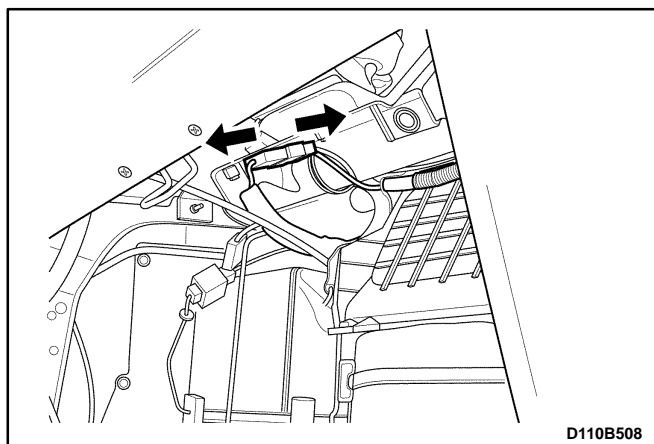

PASSENGER AIRBAG MODULE (Left-Hand Drive Shown, Right-Hand Drive Similar)

Tool Required

DS 401 Torx Bolt Wrench.

Removal Procedure

1. Disconnect the negative battery cable.
2. Remove the glove box. Refer to *Section 9E, Instrument/Driver Information*.
3. Disconnect the passenger airbag module connector.
4. Remove the passenger airbag module.
 - Remove the nuts (1).
 - Remove the airbag module torx bolts using a torx bolt wrench DS 401.
 - a. Passenger airbag module torx bolt.
 - Remove the passenger airbag module (2).

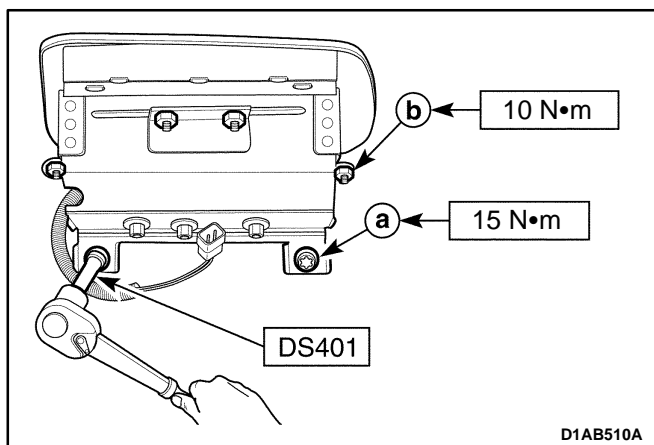
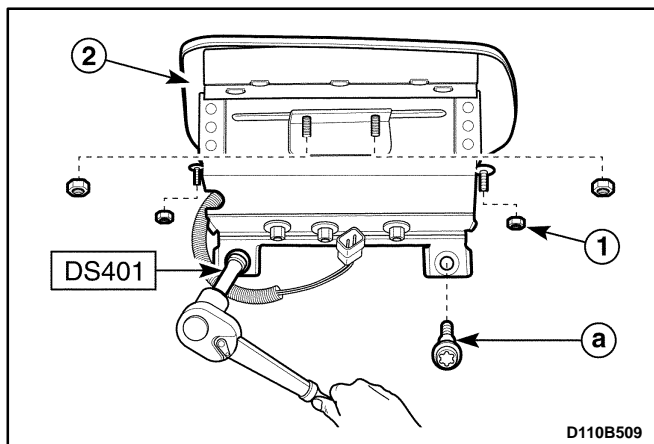

Installation Procedure

1. Install the passenger airbag module.
2. Install the passenger airbag module mounting torx bolts and the nuts using a torx bolt wrench DS 401.

Tighten

- Tighten the passenger airbag module torx bolts to 15 N•m (11 lb-ft).
 - a. Passenger airbag module torx bolt.
- Tighten the passenger airbag module nuts to 10 N•m (89 lb-in).
 - b. Passenger airbag module nut.

Notice : Do not reuse the removed torx bolts. Replace the torx bolts with the new ones.

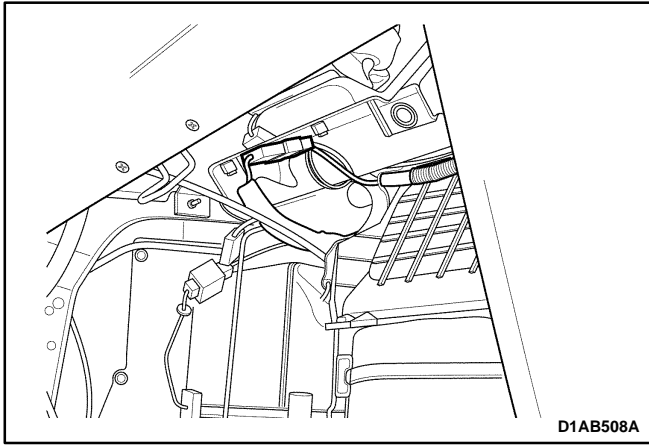

3. Connect the passenger airbag module connector.
4. Install the glove box. Refer to *Section 9E, Instrument/Driver Information*.
5. Connect the negative battery cable.

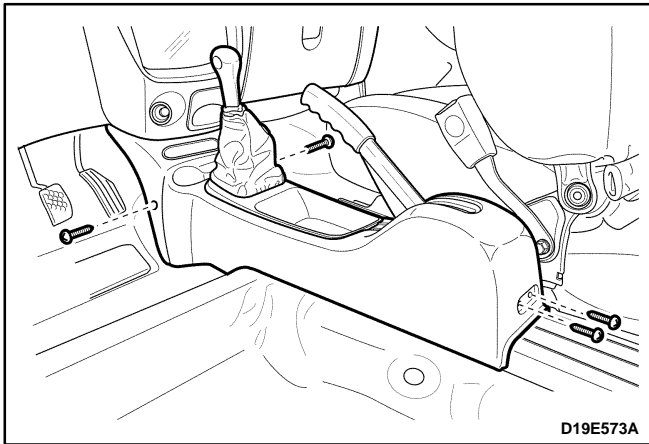

SENSING AND DIAGNOSTIC MODULE (SDM)

Tool Required

DS 401 Torx Bolt Wrench.

Removal Procedure

1. Disconnect the negative battery cable.
2. Remove the floor console. Refer to *Section 9G, Interior Trim*.

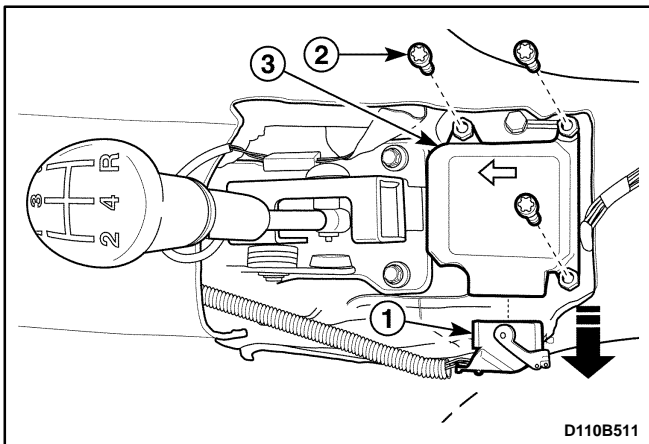

3. Remove the SDM.
 - Disconnect the SDM electrical connector (1).
 - Remove the torx bolts using a torx bolt wrench DS 401 (2).
 - Remove the SDM (3).

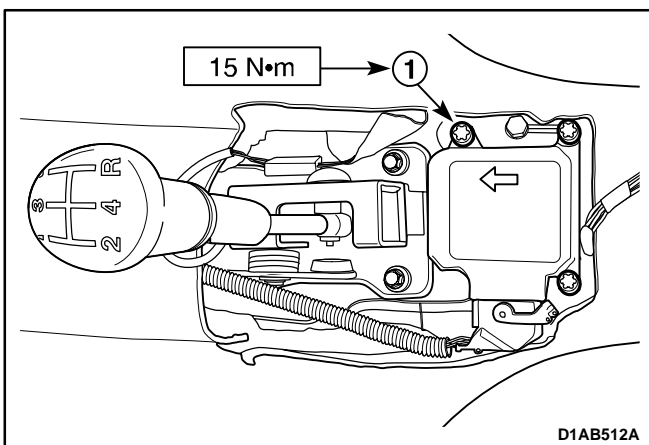

Installation Procedure

Notice: Do not install an SDM that has been dropped or has water damage, dents, cracks, or other visible defects. Attempted use of a defective SDM can result in vehicle damage.

1. Install the SDM with the mounting torx bolts so that the arrow on the SDM label points toward the front of the vehicle.

Notice : Ground the wiring harness to the mounting torx bolt (1).

Tighten

Tighten the SDM mounting torx bolts to 15 N•m (11 lb-ft).

2. Connect the SDM electrical connector.

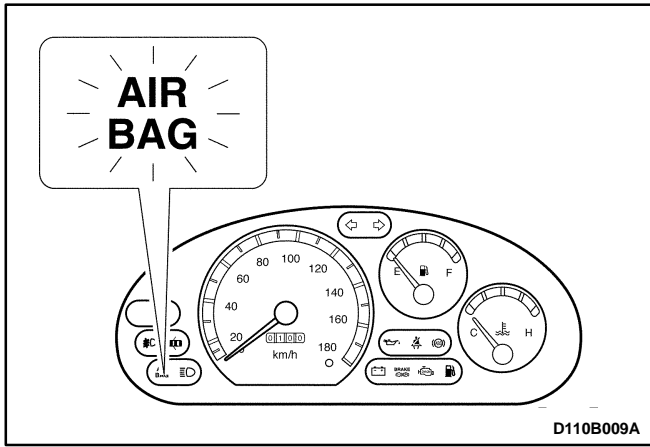

3. Install the floor console. Refer to *Section 9G, Interior Trim*.
4. Connect the negative battery cable.
5. Check for proper operation of the system.
 - Turn the ignition ON while watching the supplemental inflatable restraints warning lamp.
 - The warning lamp should turn ON for about 4 seconds, and then turn OFF.

AIRBAG MODULE DEPLOYMENT (IN VEHICLE)

(Left-Hand Drive Shown, Right-Hand Drive Similar)

Deploy the airbags before disposing of them. This includes those in a whole vehicle being scrapped.

If the vehicle is still within the warranty period, contact the Daewoo regional service manager for approval or special instructions before deploying the airbag modules.

Caution: Before deploying the airbags, remove all loose objects from the airbags expansion area.

Caution: Deploy the airbags with the vehicle doors closed and the side windows open.

Caution: Deploy the airbags only in an evacuated area. Service personnel who must be present during the deployment should be at least 10 meters (33 feet) in front of the vehicle.

Caution: Do not connect the voltage source until after having completed all other preparations for the deployment of the airbags.

Caution: Allow a deployed airbag module to cool for at least 30 minutes before handling.

Caution: Wear the gloves and the eye protectors during the disposal process.

Caution: If the deployment fails, disconnect the voltage source and wait 5 minutes before approaching the vehicle.

Deployment Procedure

1. Disconnect both battery cables and place the battery at least 10 meters (32.8 feet) from the vehicle.

Caution: Wait 1 minute after disconnecting both battery cables to allow the capacitor inside the sensing and diagnostic module (SDM) to discharge before taking any other action. The capacitor supplies the reserve power to deploy the airbags, even if the battery is disconnected. Unintentional deployment of the airbags can cause injury.

2. Remove the lower cover from the steering column.
3. At the lower steering column, cut the two wires leading from the supplemental inflatable restraint (SIR) harness to the clock spring.
4. Strip 13 mm (0.5 inch) of insulation from the ends of the wires leading to the clock spring.
5. Use two additional wires, each at least 10 meters (33 feet) long, to reach from the deployment battery to the airbag module.
6. Strip 13 mm (0.5 inch) of insulation from the ends of these two additional wires.
7. Twist the two wires together at one end.

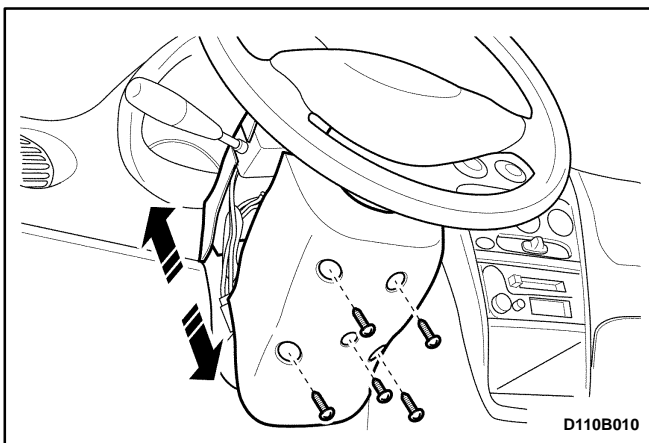

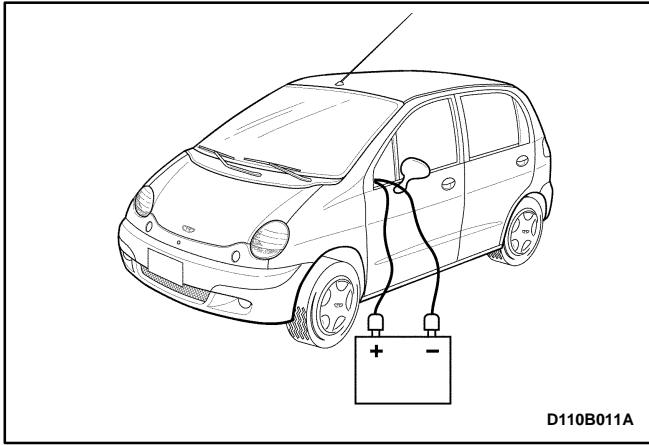

8. Place the twisted ends of the two wires near the deployment battery. Do not connect the wires to the battery at this time.
9. Using the free ends of the 10 meters (33 feet) wires leading to the clock spring, make two splices, one at each wire from the airbag module.
10. Wrap the splices with insulating tape.
11. Now that the free ends of the 10 meters (33 feet) wires are spliced to the airbag module wires, and the ends that are twisted together are near the deployment battery, clear the area.
12. Untwist the wires that are near the deployment battery.
13. Touch one wire to the positive battery terminal and touch the other wire to the negative battery terminal. The airbag will deploy.
14. Repeat the procedure for the passenger airbag, cutting the wires to the passenger airbag module instead of the wires leading to the clock spring.
15. Strip 13 mm (0.5 inch) of insulation from the ends of the wires leading to the passenger airbag module.
16. Use two additional wires, each at least 10 meters (33 feet) long, to reach from the deployment battery to the passenger airbag module.
17. Strip 13 mm (0.5 inch) of insulation from the ends of these two additional wires.
18. Twist the two wires together at one end.
19. Place the twisted ends of the two wires near the deployment battery. Do not connect the wires to the battery at this time.
20. Using the free ends of the 10 meter (33 feet) wires to the passenger airbag module, make two splices, one at each wire from the airbag module.
21. Wrap the splices with insulating tape.
22. Now that the free ends of the 10 meters (33 feet) wires are spliced to the passenger airbag module wires, and the ends that are twisted together are near the deployment battery, clear the area.
23. Untwist the wires that are near the deployment battery.
24. Touch one wire to the positive battery terminal and touch the other wire to the negative battery terminal. The passenger airbag will deploy.
25. Using the proper precautions, dispose of the deployed airbag. Refer to "Deployed Airbag Module Disposal Procedure" in this section.

AIRBAG MODULE DEPLOYMENT (OUTSIDE OF VEHICLE)

Deploy all intact airbag modules that have been

- Removed from a scrapped vehicle.
- Found to be defective.
- Found to have been damaged during transit, storage, or service.

Caution: *Deploy the airbags only in an evacuated area. Service personnel who must be present during the deployment should be at least 10 meters (33 feet) in front of the vehicle.*

Caution: *Do not connect the voltage source until completing all other preparations for the deployment of the airbags.*

Caution: *Allow a deployed airbag module to cool for at least 30 minutes before removing it from the vehicle.*

Caution: *Wear gloves and eye protection during the disposal process.*

Caution: *If the deployment fails, disconnect the voltage source and wait 5 minutes before approaching the vehicle.*

1. Position the airbag module face up, on flat ground outdoors, at least 10 meters (33 feet) from any obstacles or people.
2. Place a vehicle battery at least 10 meters (33 feet) away from the airbag module.
3. Deploy the airbag module using the deployment tool.
4. Using the proper precautions, dispose of the deployed airbag. Refer to "Deployed Airbag Module Disposal Procedure" in this section.

DEPLOYED AIRBAG MODULE DISPOSAL PROCEDURE

Caution: *After an airbag module has been deployed, the surface of the airbag may contain a powdery residue. The powder lubricates the airbag as it inflates. The dust that is produced as a by-product of the deployment is unlikely to be harmful, but use the gloves and the safety glasses in order to prevent any possible irritation of the skin and the eyes.*

Caution: *After deployment, the metal surfaces of the airbag module will be hot. In order to avoid the risk of an injury or a fire, do not place the deployed airbag modules near any flammable objects, and allow the airbag modules to cool for 30 minutes before handling them.*

Deploy an airbag before disposing of it. This includes those in a whole vehicle being scrapped.



If the vehicle is still within the warranty period, contact the Daewoo regional service manager for approval or special instructions before deploying an airbag module. Deployed airbag modules should be disposed of in the same manner as any other scrap parts, with the addition of the following steps:

1. Place the deployed airbag in a sturdy plastic bag.
2. Seal the plastic bag securely.
3. Wash your hands and rinse them with water after handling a deployed airbag.

SPECIFICATIONS

FASTENER TIGHTENING SPECIFICATIONS

Application	N•m	Lb-Ft	Lb-In
Clock Spring Mounting Screws	3	-	27
Driver Airbag Module Mounting Bolts	15	11	-
Passenger Airbag Module Mounting Nuts	10	-	89
Passenger Airbag Module Mounting Bolts	15	11	-
Sensing and Diagnostic Module Mounting Bolts	15	11	-

SPECIAL TOOLS AND EQUIPMENT

SPECIAL TOOLS TABLE

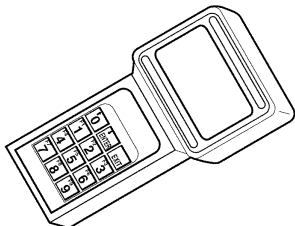
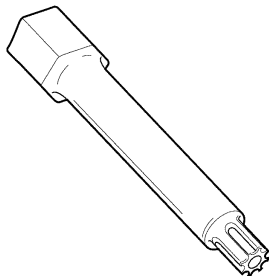
 <p style="text-align: center;">D102F101</p>	<p>Scan Tool</p>	 <p style="text-align: center;">D110B101</p>	<p>DS 401 Torx Bolt Wrench</p>
--	-------------------------	---	---

SCHEMATIC AND ROUTING DIAGRAMS

SUPPLEMENTAL INFLATABLE RESTRAINTS (SIR) ELECTRICAL SCHEMATIC

