SECTION 6B

POWER STEERING PUMP

TABLE OF CONTENTS

Description and Operation	6B-2	Pump Assembly	6B-5
Power Steering Pump	6B-2	Unit Repair	6B-7
Diagnostic Information and Procedures	6B-3	Pump	6B-7
Power Steering Pump	6B-3	Specifications	6B-8
Repair Instructions	6B-4	General Specifications	6B-8
On-Vehicle Service	6B-4	Fastener Tightening Specifications	6B-8
Pump Drive Belt	6B-4	Special Tools and Equipment	6B-9
Pump Drive Pulley	6B-5	Special Tools Table	6B-9

DESCRIPTION AND OPERATION

POWER STEERING PUMP

The pump has a remote fluid reservoir. A pressure-relief valve inside the flow control valve limits pump pressure.

DIAGNOSTIC INFORMATION AND PROCEDURES

POWER STEERING PUMP

Condition	Probable Cause	Correction
Foaming, Milky Power Steering Fluid, Low Fluid Level, and Possible Low Pressure	<ul style="list-style-type: none"> Insufficient power steering fluid level. 	<ul style="list-style-type: none"> Fill the power steering fluid reservoir.
	<ul style="list-style-type: none"> Contaminated air in the power steering fluid. 	<ul style="list-style-type: none"> Bleed the power steering system.
	<ul style="list-style-type: none"> Internal leaks and overflow of the power steering pump. 	<ul style="list-style-type: none"> Replace the power steering pump.
	<ul style="list-style-type: none"> Leaks of the power steering pump housing and the soft plug. 	<ul style="list-style-type: none"> Replace the power steering pump.
Low Pressure Due to Steering Pump	<ul style="list-style-type: none"> Stuck and improperly operated power steering pump flow control valve. 	<ul style="list-style-type: none"> Replace the power steering pump.
	<ul style="list-style-type: none"> Worn power steering pump seats. 	<ul style="list-style-type: none"> Replace the power steering pump.
	<ul style="list-style-type: none"> Scores, cracks, or breaks of the pressure plate, the pump ring, the thrust plate, and the rotor. 	<ul style="list-style-type: none"> Replace the power steering pump.
	<ul style="list-style-type: none"> Sticking of the vanes in the rotor slots. 	<ul style="list-style-type: none"> Replace the power steering pump.
	<ul style="list-style-type: none"> Internal leaks and overflow of the power steering pump. 	<ul style="list-style-type: none"> Replace the power steering pump.
Growling Noise in Steering Pump	<ul style="list-style-type: none"> Restricted flow of the pump hoses and the steering gear pipes. 	<ul style="list-style-type: none"> Clean out the pipes and the hoses. Replace the pipes and the hoses as needed.
	<ul style="list-style-type: none"> Scores, cracks, or breaks of the pressure plate, the pump ring, the thrust plate, and the rotor. 	<ul style="list-style-type: none"> Replace the power steering pump.
	<ul style="list-style-type: none"> Improperly contacted power steering hose with the body. 	<ul style="list-style-type: none"> Secure the pump hose in a clamp away from the body.
	<ul style="list-style-type: none"> Insufficient power steering fluid level. 	<ul style="list-style-type: none"> Fill the power steering pump reservoir.
Ratting Noise in the Steering Pump	<ul style="list-style-type: none"> Contaminated air in the power steering fluid. 	<ul style="list-style-type: none"> Bleed the power steering system.
	<ul style="list-style-type: none"> Improperly contacted power steering hose with the body. 	<ul style="list-style-type: none"> Secure the pump hose in a clamp away from the body.
	<ul style="list-style-type: none"> Insufficient power steering fluid level. 	<ul style="list-style-type: none"> Fill the power steering pump reservoir.
	<ul style="list-style-type: none"> Improperly installed pump mounting. 	<ul style="list-style-type: none"> Tighten the power steering pump attachment bolts.
Swishing Noise in the Steering Pump	<ul style="list-style-type: none"> Damaged power steering pump flow control valve. 	<ul style="list-style-type: none"> Replace the power steering pump.
Whining Noise in the Steering Pump	<ul style="list-style-type: none"> Scores of the pressure plate and the vanes. 	<ul style="list-style-type: none"> Replace the power steering pump.
	<ul style="list-style-type: none"> Scores of the pump shaft bearing 	<ul style="list-style-type: none"> Replace the power steering pump.

REPAIR INSTRUCTIONS

ON-VEHICLE SERVICE

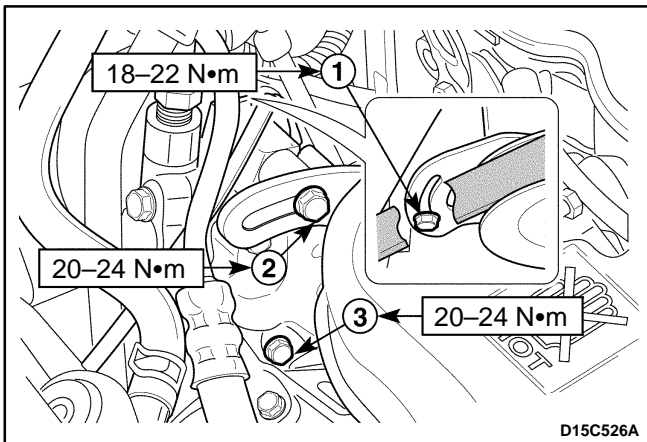
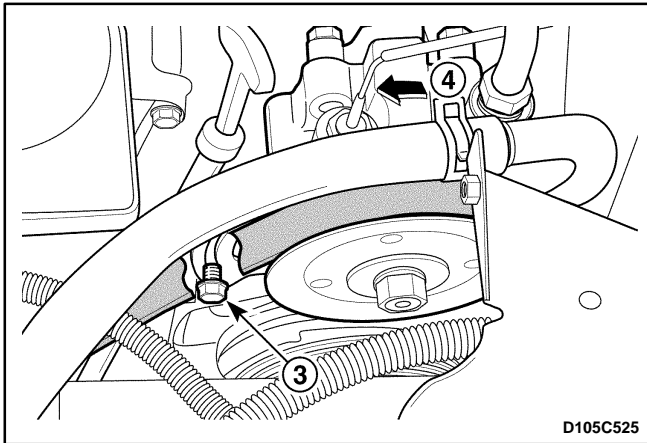
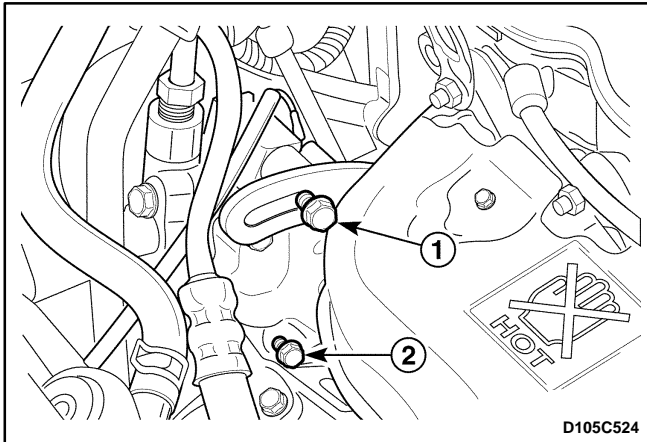

PUMP DRIVE BELT

Removal Procedure

1. Remove the front passenger side headlamp. Refer to *Section 9B, Lighting Systems*.
2. Remove the pump drive belt.
 - Loosen the rear bracket adjusting bolt (1).
 - Loosen the bolt (2).

- Loosen the front bracket adjusting bolts (3).
- Push the pump forward (4).

Installation Procedure

1. Install the pump drive belt with the bolts.

Tighten

- Tighten the front bracket adjusting bolt to 18–22 N•m (13–16 lb-ft) (1).
 - Tighten the rear bracket adjusting bolt to 20–24 N•m (15–18 lb-ft) (2).
 - Tighten the power steering pump bolt to 20–24 N•m (15–18 lb-ft) (3).
2. Install the front passenger side headlamp. Refer to *Section 9B, Lighting Systems*.

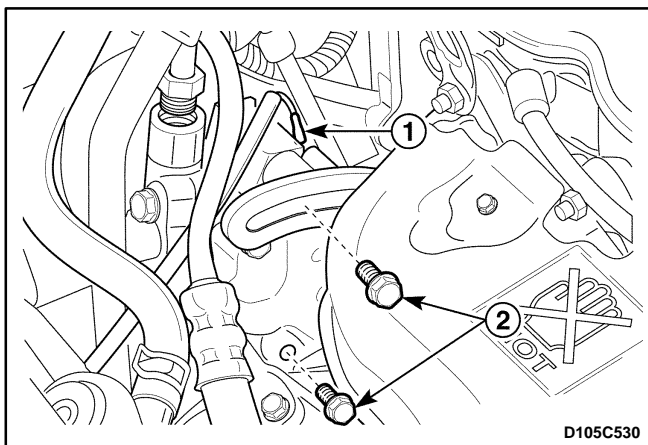
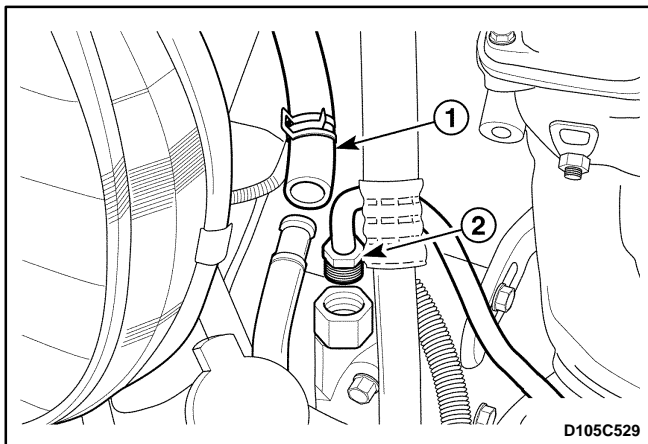
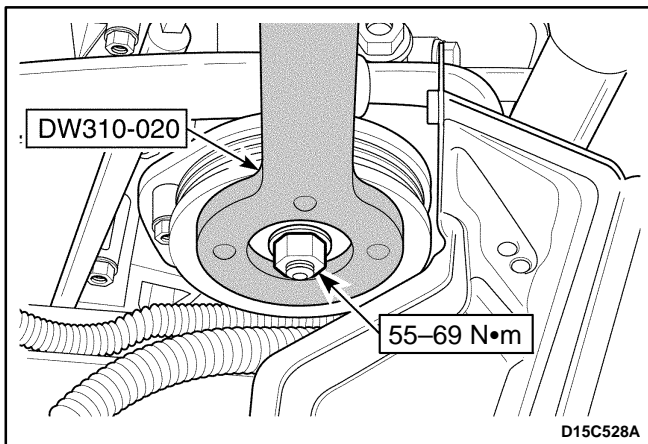
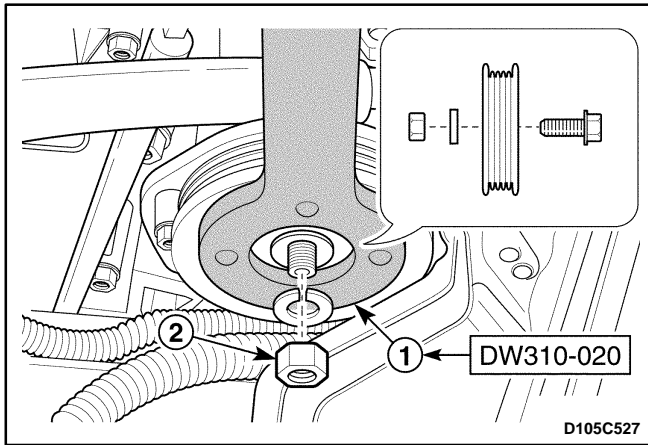

PUMP DRIVE PULLEY

Tools Required

DW310-020 Power Steering Pulley Remove Holder

Removal Procedure

1. Remove the front passenger side headlamp.
Refer to *Section 9B, Lighting Systems*.
2. Remove the steering pump pulley.
 - Remove the pump drive belt. Refer to "Pump Drive Belt" in this section.
 - Fix the pulley using the power steering pulley remove holder DW310-020 (1).
 - Remove the pump drive pulley nut (2).

Installation Procedure

1. Install the pump drive pulley. Install the steering pump pulley nut.
2. Install the pump drive belt.
3. Tighten the steering pump pulley nut using the power steering pulley remove holder DW310-020.

Tighten

Tighten the steering pump pulley nuts to 55-69 N·m (41-51 lb-ft).

4. Install the front passenger side headlamp.
Refer to *Section 9B, Lighting Systems*.

PUMP ASSEMBLY

Removal Procedure

1. Remove the front passenger side headlamp.
Refer to *Section 9B, Lighting Systems*.
2. Disconnect the pipe line from the pump.
 - Disconnect the supply line pipe hose (1).
 - Disconnect the pressure line pipe fitting (2).
3. Remove the power steering pump.
 - Remove the pump drive belt. Refer to "Pump Drive Belt" in this section.
 - Disconnect the power steering pressure switch connector (1). Refer to *Section 6A, Power Steering Systems*.
 - Remove the bolts (2).

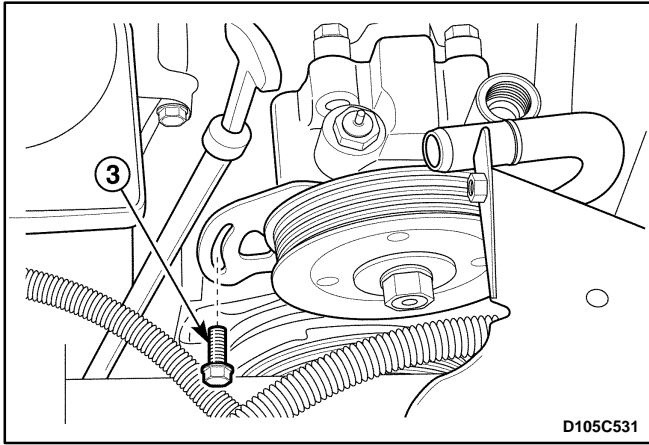

- Remove the bolt (3).

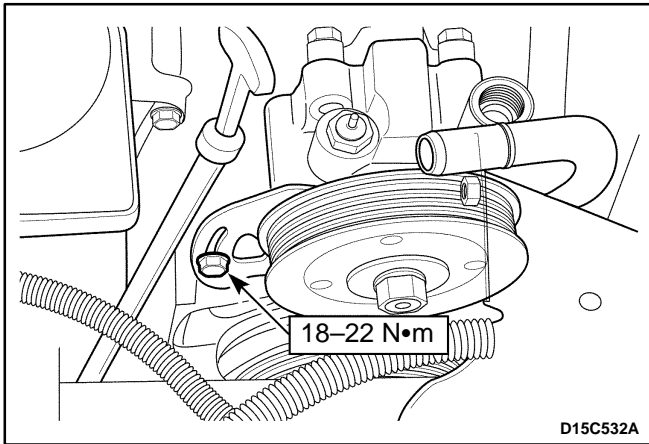

Installation Procedure

1. Install the power steering pump with the bolt.

Tighten

Tighten the bolt to 18–22 N•m (13–16 lb-ft).

2. Connect the power steering pressure switch connector. Refer to *Section 6A, Power Steering System*.
3. Install the pump drive belt. Refer to “Pump Drive Belt” in this section.

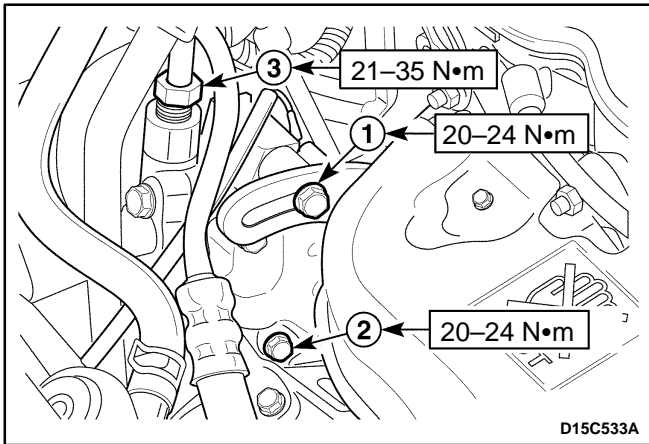

4. Install the bolts.

Tighten

- Tighten the rear bracket adjusting bolt to 20–24 N•m (15–18 lb-ft) (1).
 - Tighten the power steering bolt to 20–24 N•m (15–18 lb-ft) (2).
5. Connect the pressure line pipe to the outlet connection on the steering pump.

Tighten

Tighten the pressure line pipe fitting to 21–35 N•m (16–26 lb-ft) (3).

6. Install the front passenger side headlamp.
Refer to *Section 9B, Lighting Systems*.

Notice: When adding fluid or making a complete fluid change, always use DEXRON®-II or DEXRON®-III power steering fluid. Failure to use the proper fluid will cause hose and seal damage and fluid leaks.

7. Refill the pump with new fluid and bleed the air from the system. Refer to *Section 6A, Bleeding the Power Steering System*.
8. Inspect for leaks. If leaks are found, correct the cause of the leak and bleed the system.

UNIT REPAIR

PUMP

The power steering pump in this vehicle is not serviceable. A faulty pump must be replaced.

SPECIFICATIONS

GENERAL SPECIFICATIONS

Application	Description
Lubricant	Power Steering Fluid DEXRON®-II, DEXRON®-III
Capacity	1.0 Liter (1.056 qt)
Type	Vane

FASTENER TIGHTENING SPECIFICATIONS

Application	N•m	Lb-Ft	Lb-In
Power Steering Pump Bolt	20 – 24	15 – 18	–
Power Steering Pump Front Bracket Bolt	20 – 24	15 – 18	–
Power Steering Pump Front Bracket Adjusting Bolt	18 – 22	13 – 16	–
Power Steering Pump Rear Bracket Upper Bolt	35 – 45	26 – 33	–
Power Steering Pump Rear Bracket Lower Bolt	20 – 24	15 – 18	–
Power Steering Pump Rear Bracket Adjusting Bolt	20 – 24	15 – 18	–
Power Steering Pump Pulley Nut	55 – 69	41– 51	–
Power Steering Oil Pressure Line Fitting	21 – 35	16 – 26	–

SPECIAL TOOLS AND EQUIPMENT

SPECIAL TOOLS TABLE

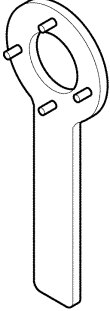
 <p>D105C101</p>	<p>DW310-020 Power Steering Pulley Remove Holder</p>
---	---

SECTION 6C

POWER STEERING GEAR

CAUTION: *Disconnect the negative battery cable before removing or installing any electrical unit or when a tool or equipment could easily come in contact with exposed electrical terminals. Disconnecting this cable will help prevent personal injury and damage to the vehicle. The ignition must also be in B unless otherwise noted.*

TABLE OF CONTENTS

Description and Operation	6C-2	Unit Repair	6C-8
Power Rack and Pinion	6C-2	Tie Rod End Boot	6C-8
Diagnostic Information and Procedures	6C-3	Hydraulic Cylinder Lines	6C-8
Power Rack and Pinion Steering Gear	6C-3	Rack and Pinion Steering Gear	6C-9
Adjust the Free Load of the Steering Gear ...	6C-5	Assembly	
Repair Instructions	6C-6	Specifications	6C-13
On-Vehicle Service	6C-6	General Specifications	6C-13
Rack and Pinion Assembly	6C-6	Fastener Tightening Specifications	6C-13
Power Steering Gear Rack and Pinion Boot ...	6C-7		

DESCRIPTION AND OPERATION

POWER RACK AND PINION

The power rack and pinion steering system has a rotary control valve which directs the hydraulic fluid coming from the hydraulic pump to one side or the other side of the rack piston. The integral rack piston is attached to the rack. The rack piston converts hydraulic pressure to a linear force which moves the rack left or right. The force is then transmitted through the tie rods and the tie

rod ends to the steering knuckles, which turn the wheels.

If hydraulic assist is not available, manual control is maintained. However, under these conditions, more steering effort is required. The movement of the steering wheel is transferred to the pinion. The movement of the pinion is then transferred through the pinion teeth, which meshes with the teeth on the rack, causing the rack to move.

DIAGNOSTIC INFORMATION AND PROCEDURES

POWER RACK AND PINION STERING GEAR

Condition	Probable Cause	Correction
Hissing Noise	<ul style="list-style-type: none"> Loose steering coupling joints. 	<ul style="list-style-type: none"> Tighten the steering coupling joints.
	<ul style="list-style-type: none"> Improperly contacted the power steering hose with other components. 	<ul style="list-style-type: none"> Fit the power steering hose into the hose clips correctly.
Rattling Noise in Steering Gear	<ul style="list-style-type: none"> Improperly contacted the power steering line with the body. 	<ul style="list-style-type: none"> Fix the steering line correctly.
	<ul style="list-style-type: none"> Insufficient lubricant. 	<ul style="list-style-type: none"> Lubricate the steering gear.
	<ul style="list-style-type: none"> Loose steering gear mounting. 	<ul style="list-style-type: none"> Tighten the steering gear mounting bracket bolts.
	<ul style="list-style-type: none"> Improperly installed tie rod ends. 	<ul style="list-style-type: none"> Tighten the tie rod joints and replace the tie rod end as needed.
Poor Return of Steering Wheel to Center	<ul style="list-style-type: none"> Improperly contacted the steering wheel with the turn signal housing. 	<ul style="list-style-type: none"> Adjust the turn signal housing.
	<ul style="list-style-type: none"> Improper binding or looseness of steering coupling. 	<ul style="list-style-type: none"> Replace the intermediate shaft.
	<ul style="list-style-type: none"> Stuck and improperly aligned power steering pump flow control valve. 	<ul style="list-style-type: none"> Replace the power steering pump.
	<ul style="list-style-type: none"> Improper binding or looseness of tie rods and ball joints. 	<ul style="list-style-type: none"> Tighten the tie rods and the ball joints. Replace the tie rods and the ball joints as needed.
	<ul style="list-style-type: none"> Poor adjustments of the steering gear. 	<ul style="list-style-type: none"> Perform a straight-ahead check.
Momentary Increase in Effect When Turning the Wheel Quickly	<ul style="list-style-type: none"> Internal leaks of the power steering pump. 	<ul style="list-style-type: none"> Replace the power steering pump.
	<ul style="list-style-type: none"> The damage or restricted flow of the hoses. 	<ul style="list-style-type: none"> Replace the power steering hoses and pipes.
	<ul style="list-style-type: none"> Insufficient power steering fluid. 	<ul style="list-style-type: none"> Fill the power steering fluid reservoir.
	<ul style="list-style-type: none"> Stuck and improperly operated power steering pump flow control valve. 	<ul style="list-style-type: none"> Replace the power steering pump.
Steering Surges or Jerks When Turning with Engine Running	<ul style="list-style-type: none"> Insufficient pressure of the power steering pump. 	<ul style="list-style-type: none"> Replace the power steering pump.
	<ul style="list-style-type: none"> Stuck and improperly operated power steering pump flow control valve. 	<ul style="list-style-type: none"> Replace the power steering pump.
	<ul style="list-style-type: none"> The slippage of the pump drive belt. 	<ul style="list-style-type: none"> Tighten the pump drive belt.
	<ul style="list-style-type: none"> Contaminated air in the power steering system. 	<ul style="list-style-type: none"> Bleed the power steering system.

POWER RACK AND PINION STERING GEAR (Cont'd)

Condition	Probable Cause	Correction
Excessive Wheel Kickback or Loose Steering	<ul style="list-style-type: none"> ● Contaminated air in the power steering system. 	<ul style="list-style-type: none"> ● Bleed the power steering system.
	<ul style="list-style-type: none"> ● Worn or damaged wheel bearings. 	<ul style="list-style-type: none"> ● Replace the wheel bearings.
	<ul style="list-style-type: none"> ● Loose steering gear mounting. 	<ul style="list-style-type: none"> ● Tighten the steering gear mounting bracket bolts.
	<ul style="list-style-type: none"> ● Improperly installed steering gear-to-intermediate shaft joints. 	<ul style="list-style-type: none"> ● Tighten the joint bolt.
	<ul style="list-style-type: none"> ● Loose tie rods and ball joints. 	<ul style="list-style-type: none"> ● Tighten the tie rods and the ball joints. ● Replace the tie rods and the ball joints as needed.
Hard Steering or Lack of Assist (Especially During Parking)	<ul style="list-style-type: none"> ● Stuck and improperly installed power steering pump flow control valve. 	<ul style="list-style-type: none"> ● Replace the power steering pump.
	<ul style="list-style-type: none"> ● Insufficient pressure of the power steering pump. 	<ul style="list-style-type: none"> ● Replace the power steering pump.
	<ul style="list-style-type: none"> ● Internal leaks of power steering pump. 	<ul style="list-style-type: none"> ● Replace the power steering pump.
	<ul style="list-style-type: none"> ● Improper tension of the pump drive belt. 	<ul style="list-style-type: none"> ● Adjust the pump drive belt tension.

ADJUST THE FREE LOAD OF THE STEERING GEAR

1. Place the steering wheel in the straight-ahead position.
2. Raise and suitably support the vehicle.
3. Remove the adjust plug locknut.
4. Check the torque of the adjuster plug.
5. Check the torque is below the specification value or the measured torque is over the specification value, adjust the tightening torque.
 - Place the rack gear in the straight-ahead position.
 - Tighten the adjust plug to 10 N•m (89 lb-in).
 - Turn the steering wheel all the way to the right and the left about 5 times repeatedly.
 - Place the rack gear in the straight-ahead position.
 - Loosen the adjust plug.

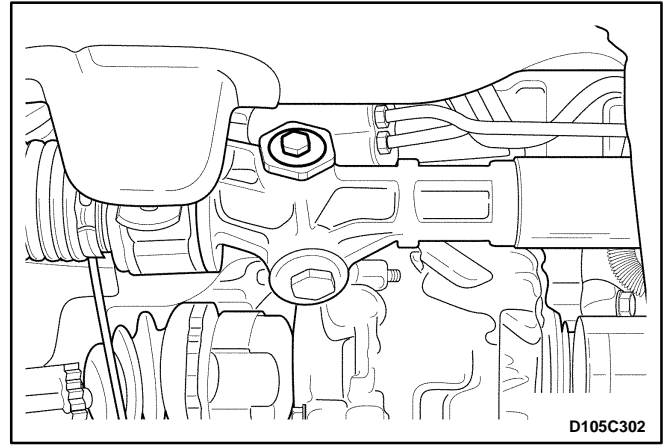

- Tighten the adjust plug to 4.5–5.5 N•m (40–49 lb-in).
 - Loosen the adjust plug to 67.5°.
6. Tighten the adjust plug locknut.

REPAIR INSTRUCTIONS

ON-VEHICLE SERVICE

RACK AND PINION ASSEMBLY

(Left-Hand Drive Shown, Right-Hand Drive Similar)

Removal Procedure

1. Remove the intermediate shaft lower pinch bolt. Refer to *Section 6E, Steering Wheel and Column*.
2. Remove the wheel. Refer to *Section 2E, Tires and Wheels*.
3. Remove the tie rod ends. Refer to *Section 6D, Manual Steering Gear*.
4. Remove the front exhaust pipe nuts. Refer to *Section 1G, Engine Exhaust*.
5. Remove the rack and pinion assembly.
 - Disconnect the return line pipe from the steering gear (1).
 - Disconnect the pressure inlet line pipe from the steering gear (2).
 - Plug the opening in the power steering pipe line to prevent fluid loss and contamination.

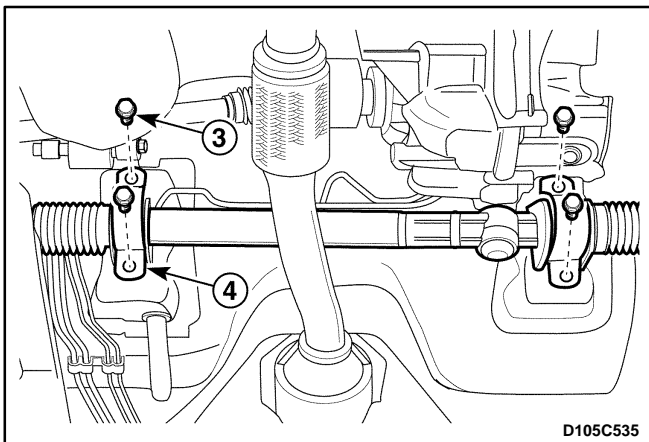
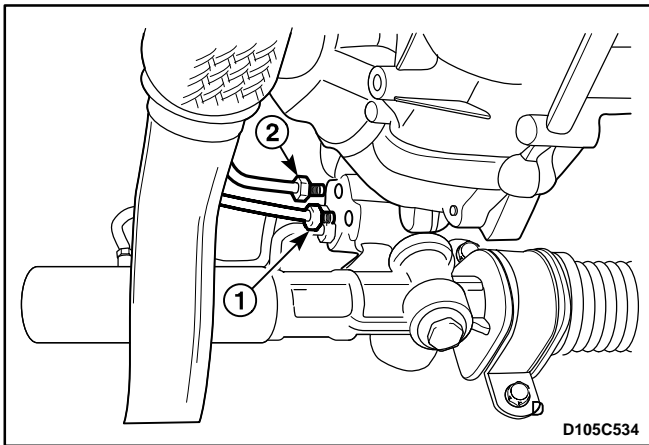

- Remove the power steering gear retaining bracket tighten bolts (3).
- Remove the power steering gear retaining bracket (4).

Important: After moving the gear toward the passenger side and pulling the gear of the driver side into the underbody hole, remove the steering gear.

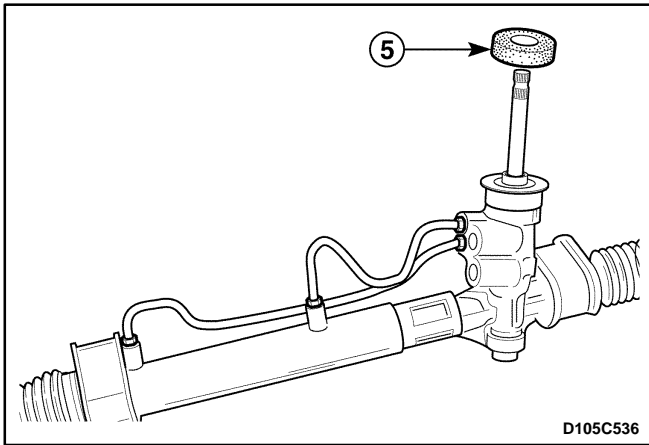

6. Remove the packing (5).

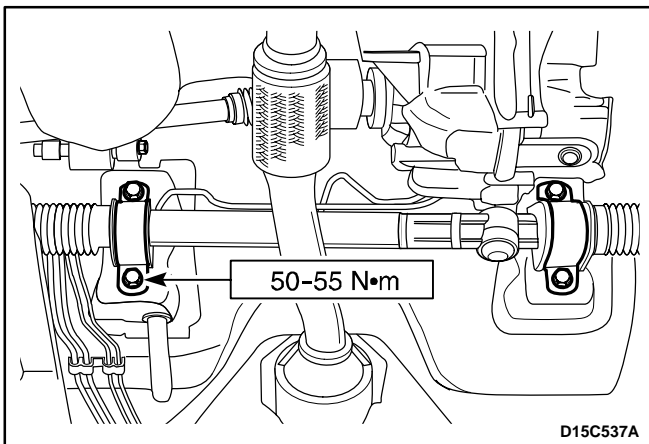

Installation Procedure

1. Install in the reverse order of removal.
2. Install the power steering gear bracket with the bolt.

Tighten

Tighten the bracket bolts to 50–55 N•m (36–41 lb-ft).

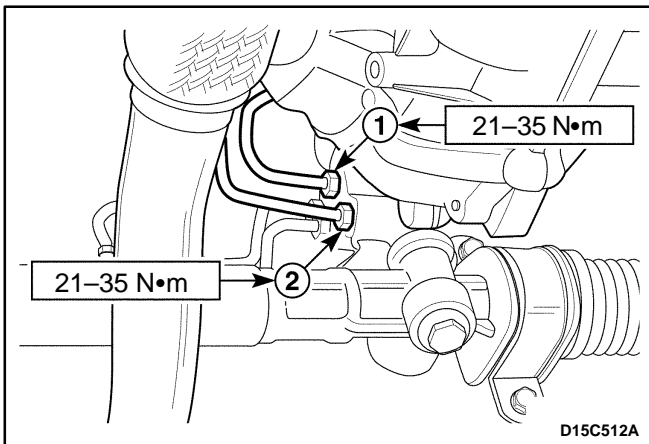

3. Connect the steering pipe. Refer to *Section 6A, Power Steering System*.

Tighten

Tighten the power steering pressure line fitting (1) to 21–35 N•m (16–25 lb-ft) (1).

Tighten the return line fitting to 21–35 N•m (16–25 lb-ft) (2).

Important: When adding fluid or making a complete fluid change, always use DEXRON® II or III power steering fluid. Failure to use the proper fluid will cause hose and seal change and fluid leaks.

4. Fill the fluid reservoir with power steering fluid.
5. Inspect for leaks. If there are leaks, correct the cause of the leaks and bleed the system. Refer to *Section 6A, Power Steering System*.

POWER STEERING GEAR RACK AND PINION BOOT

Refer to *Section 6D, Manual Steering Gear*.

UNIT REPAIR

TIE ROD END BOOT

Refer to Section 6D, Manual Steering Gear.

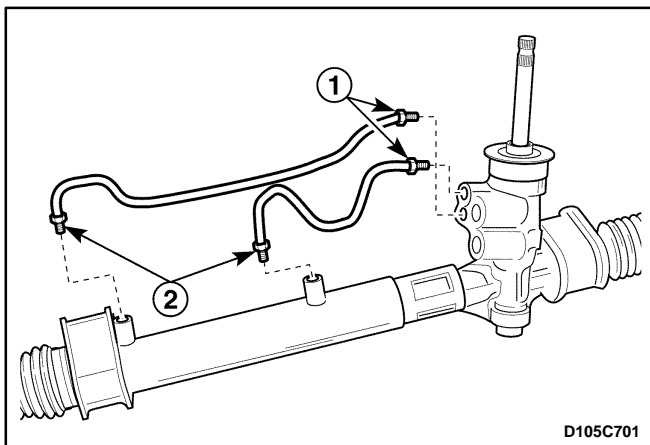

HYDRAULIC CYLINDER LINES

(Left-Hand Drive Shown, Right-Hand Drive Similar)

Disassembly Procedure

1. Remove the rack and pinion steering assembly from the vehicle. Refer to "Rack and Pinion Assembly" in this section.
2. Disconnect the cylinder lines from the rack and pinion housing.
 - Remove the fitting (1).
 - Remove the fitting (2).

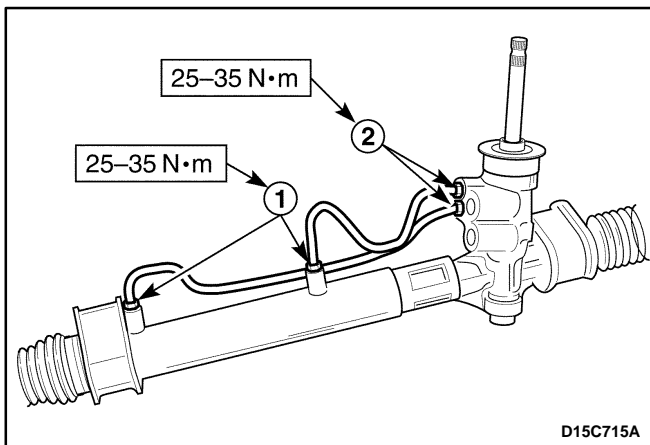

Assembly Procedure

1. Connect the cylinder lines to the rack and pinion housing.
2. Install the power steering line fittings at the pinion valve end.

Tighten

Tighten the power steering line fittings to 25–35 N·m (18–25 lb-ft) (1).

3. Install the power steering line fittings at the cylinder end.

Tighten

Tighten the power steering line fittings to 25–35 N·m (18–25 lb-ft) (2).

4. Install the rack and pinion steering assembly to the vehicle. Refer to "Rack and Pinion Assembly" in this section.

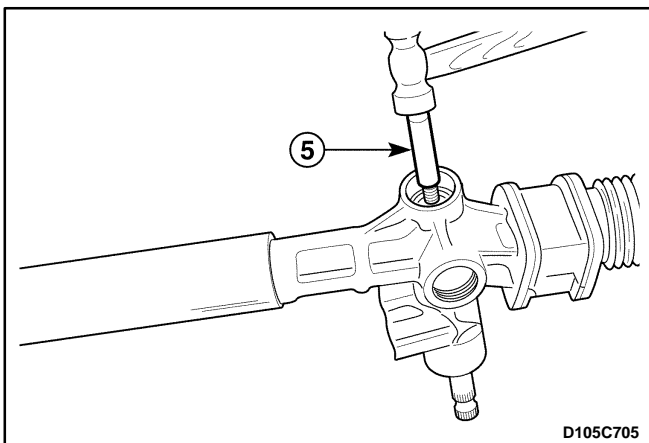
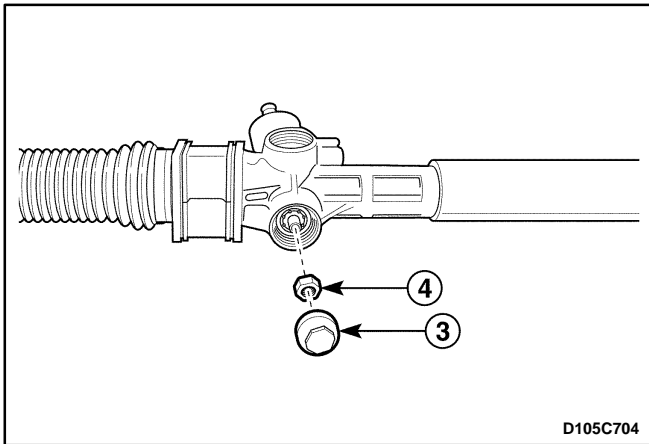
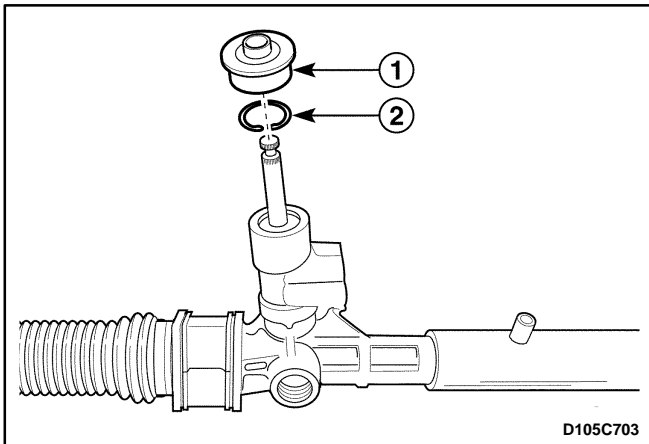
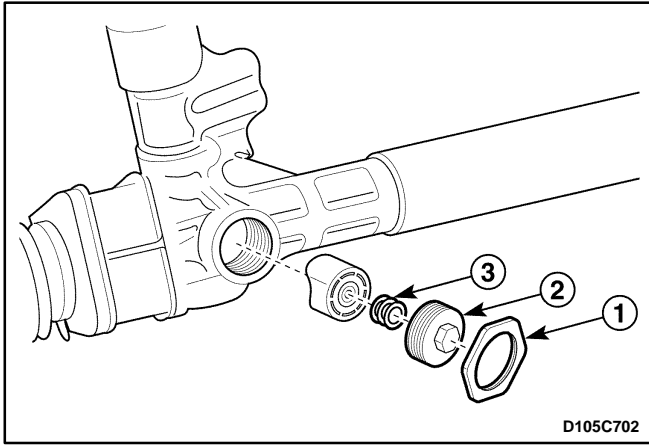

RACK AND PINION STEERING GEAR ASSEMBLY

(Left-Hand Drive Shown, Right-Hand Drive Similar)

Disassembly Procedure

1. Remove the rack and pinion steering assembly from the vehicle. Refer to "Rack and Pinion Assembly" in this section.
2. Remove the rack bearing.
 - Remove the adjuster plug locknut (1).
 - Remove the adjuster plug (2).
 - Remove the adjuster spring (3).
3. Remove the steering pinion.
 - Remove the dust cap (1).
 - Remove the retaining ring (2).

- Remove the steering pinion dust cap (3).
- Remove the steering pinion locknut (4).

Notice: If the stub shaft is not held, damage to the pinion teeth will occur. While holding the stub shaft, remove the locknut from the pinion.

- Remove the steering pinion from the pinion bearing by hitting the pinion with the flatted drift and hammer (5).

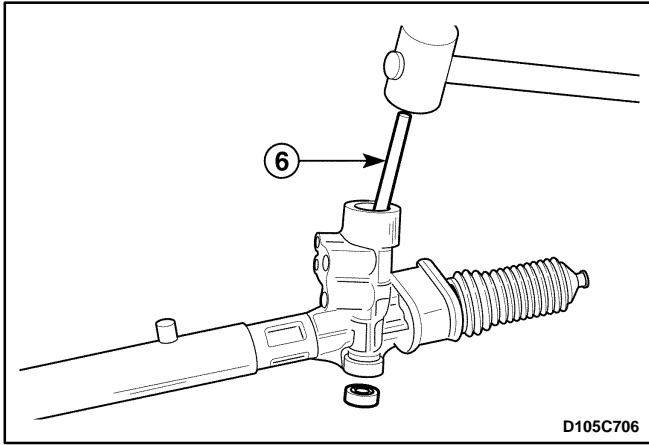

Important: Hit the drift using a hammer when the lower pinion is vertical with the drift.

- Remove the bearing by hitting the bearing with the fluted drift and rubber hammer (6).

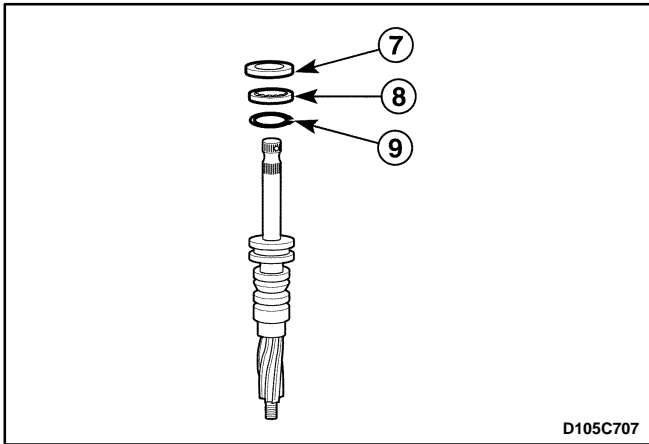

- Remove the pinion shaft seal (7).
- Remove the needle bearing (8).
- Remove the retaining ring (9).

Important: The power steering gear housing and the rack gear in this vehicle is not serviceable as unit. The faulty parts must be replaced as whole units.

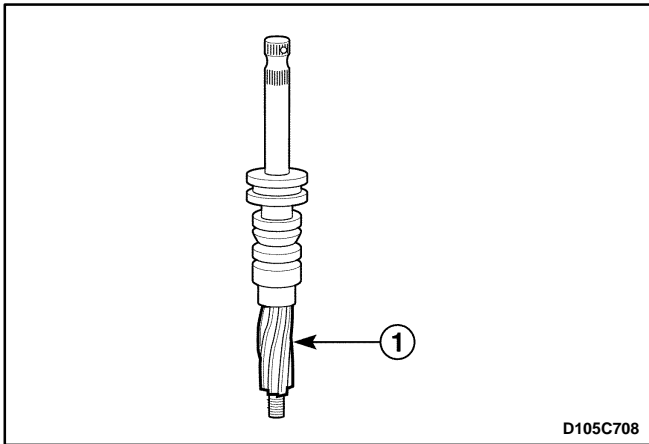

Inspection Procedure

1. Inspect the tie rod ends and the ball joints for damage. Refer to *Section 6D, Manual Steering Gear*.
2. Inspect the tie rod ends and the rack/pinion boot for cracks or abnormal wear. Refer to *Section 6D, Manual Steering Gear*.
3. Inspect the metal part for damage.
 - Inspect the pinion gear for damage or wear (1).

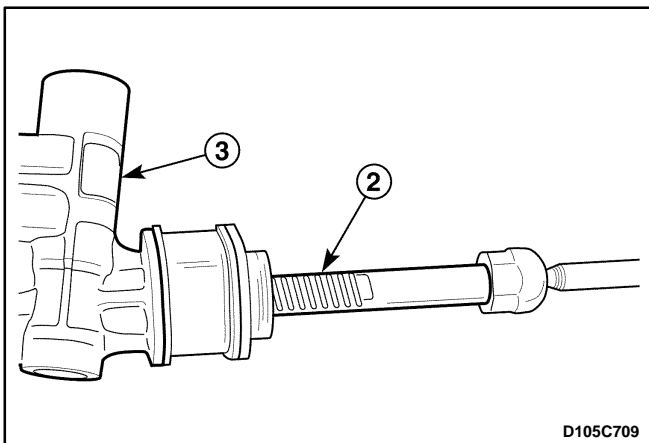

- Inspect the rack gear for damage or wear (2).
- Inspect the steering gear housing for damage or wear(3).

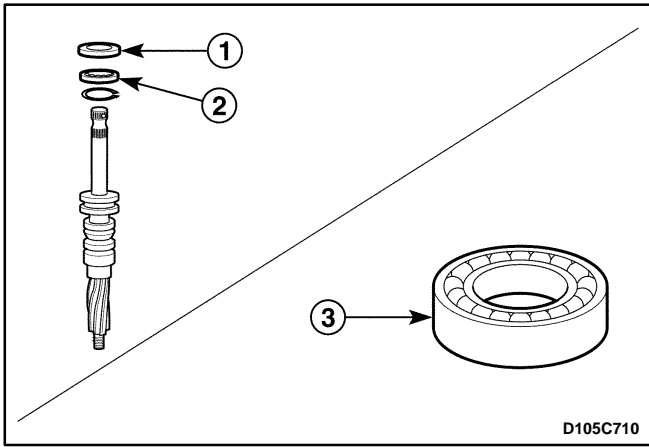

4. Inspect the bearings and the seal for damage.
 - Inspect the pinion shaft seal for leaks and wear (1).
 - Inspect the needle bearing for wear (2).
 - Inspect the pinion bearing for wear (3).
5. The faulty parts must be replaced.

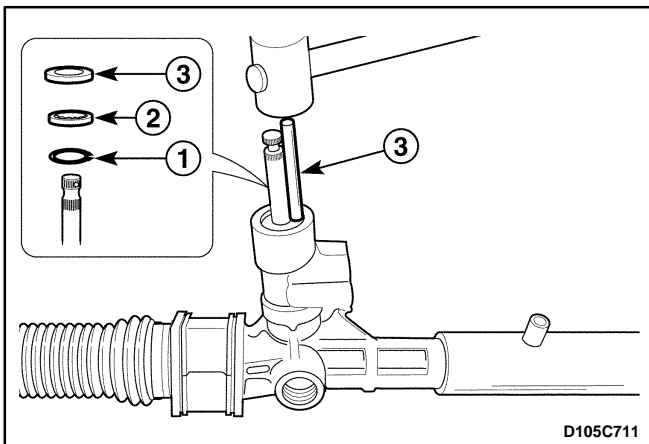

Assembly Procedrue

1. Install the steering pinion gear.
 - Install the retaining ring (1).
 - Install the needle bearing (2).
 - Install the pinion shaft seal using a drift (3).

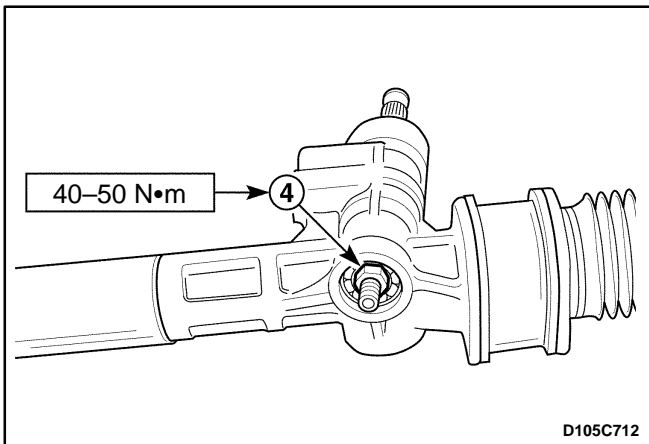

2. Install the steering pinion locknut (4).

Tighten

Tighten the pinion locknut to 40-50 N·m (30-36 lb-ft).

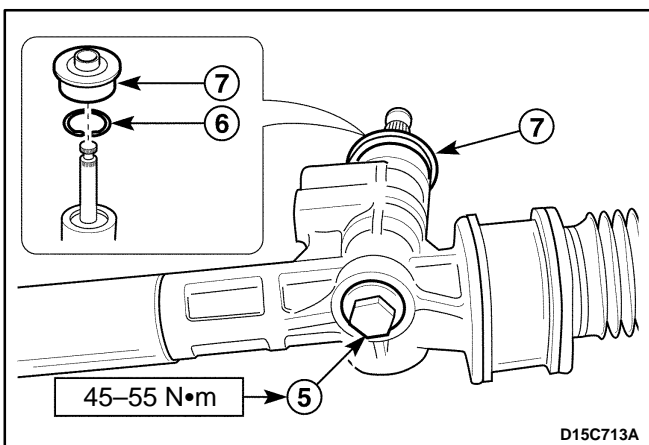

3. Install the dust cap (5).

Tighten

Tighten the dust cap to 45-55 N·m (33-41 lb-ft).

4. Install the retaining ring (6).
5. Install the plastic dust cap (7).

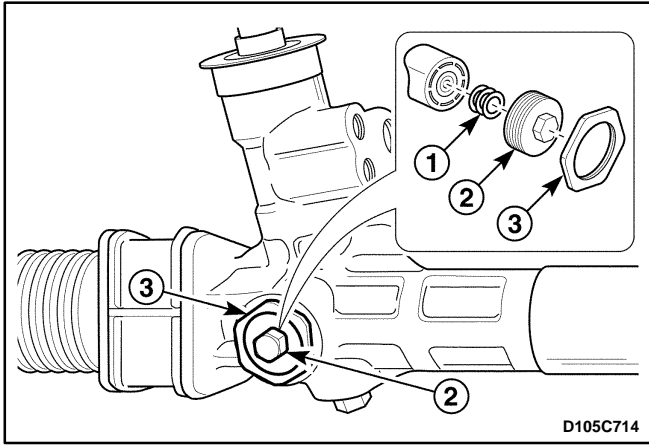

6. Install the rack bearing.
 - Install the adjuster spring (1).
 - Tighten the adjuster plug (2).
 - Tighten the plug locknut (3).
7. Install the rack and pinion steering assembly to the vehicle. Refer to "Rack and Pinion Assembly" in this section.

SPECIFICATIONS

GENERAL SPECIFICATIONS

Application			Description
Power Steering Fluid			Power Steering Fluid DEXRON®-II or DEXRON®-III
Capacity			1.0 L (1.056 qt)
Type			Rack and Pinion
Overall Gear Ratio			15.7 : 1
Power Steering Angle	144, 155 Tire	Inside	$39.5^{\circ} \pm 2^{\circ}$
		Outside	$33.5^{\circ} \pm 2^{\circ}$
	175 Tire	Inside	$34.9^{\circ} \pm 2^{\circ}$
		Outside	$30.5^{\circ} \pm 2^{\circ}$
Grease		Rack	POLYUREAS
		Ball Joint	SYNTHETICS OILS & LI SOAPS

FASTENER TIGHTENING SPECIFICATIONS

Application	N•m	Lb-Ft	Lb-In
Power Steering Gear Bracket Bolt	50-55	36-41	-
Power Steering Gear Pinion Nut	40-50	30-36	-
Power Steering Gear Pinion Dust Cover	45-55	33-41	-
Power Steering Gear Pressure Line Fitting	25-35	18-25	-
Power Steering Oil Pressure Pipe Fitting (Gear Side)	21-35	16-25	-
Power Steering Gear Adjuster Plug	Refer to "DIAGNOSIS" in this section.		

SECTION 6D

MANUAL STEERING GEAR

CAUTION: Disconnect the negative battery cable before removing or installing any electrical unit or when a tool or equipment could easily come in contact with exposed electrical terminals. Disconnecting this cable will help prevent personal injury and damage to the vehicle. The ignition must also be in B unless otherwise noted.

TABLE OF CONTENTS

Description and Operation	6D-2	On-Vehicle Service	6D-7
Manual Rack and Pinion	6D-2	Tie Rod End	6D-7
Component Locator	6D-3	Rack and Pinion Boot	6D-8
Manual Rack and Pinion Steering Gear	6D-3	Rack and Pinion Steering Gear Assembly	6D-9
Diagnostic Information and Procedures	6D-4	Unit Repair	6D-11
Manual Rack and Pinion Steering Gear	6D-4	Tie Rod End Boot	6D-11
Straight-Ahead Check	6D-5	Rack and Pinion	6D-11
Steering Wheel Restoration	6D-6	Specifications	6D-17
Check The Turning Resistance of the Tie Rod End or Tie Rod	6D-6	General Specifications	6D-17
Adjust the Free Load of the Steering Gear	6D-6	Fastener Tightening Specifications	6D-17
Repair Instructions	6D-7	Special Tools and Equipment	6D-18
		Special Tools Table	6D-18

DESCRIPTION AND OPERATION

MANUAL RACK AND PINION

The manual rack and pinion steering system consists of two main components: the rack and the pinion. The motion of the pinion is transferred through the pinion teeth that mesh with the teeth on the rack, which moves the rack. The force is then transmitted through the arms on the struts, which turn the wheels.

COMPONENT LOCATOR

MANUAL RACK AND PINION STEERING GEAR

(Left-Hand Drive Shown, Right-Hand Drive Similar)

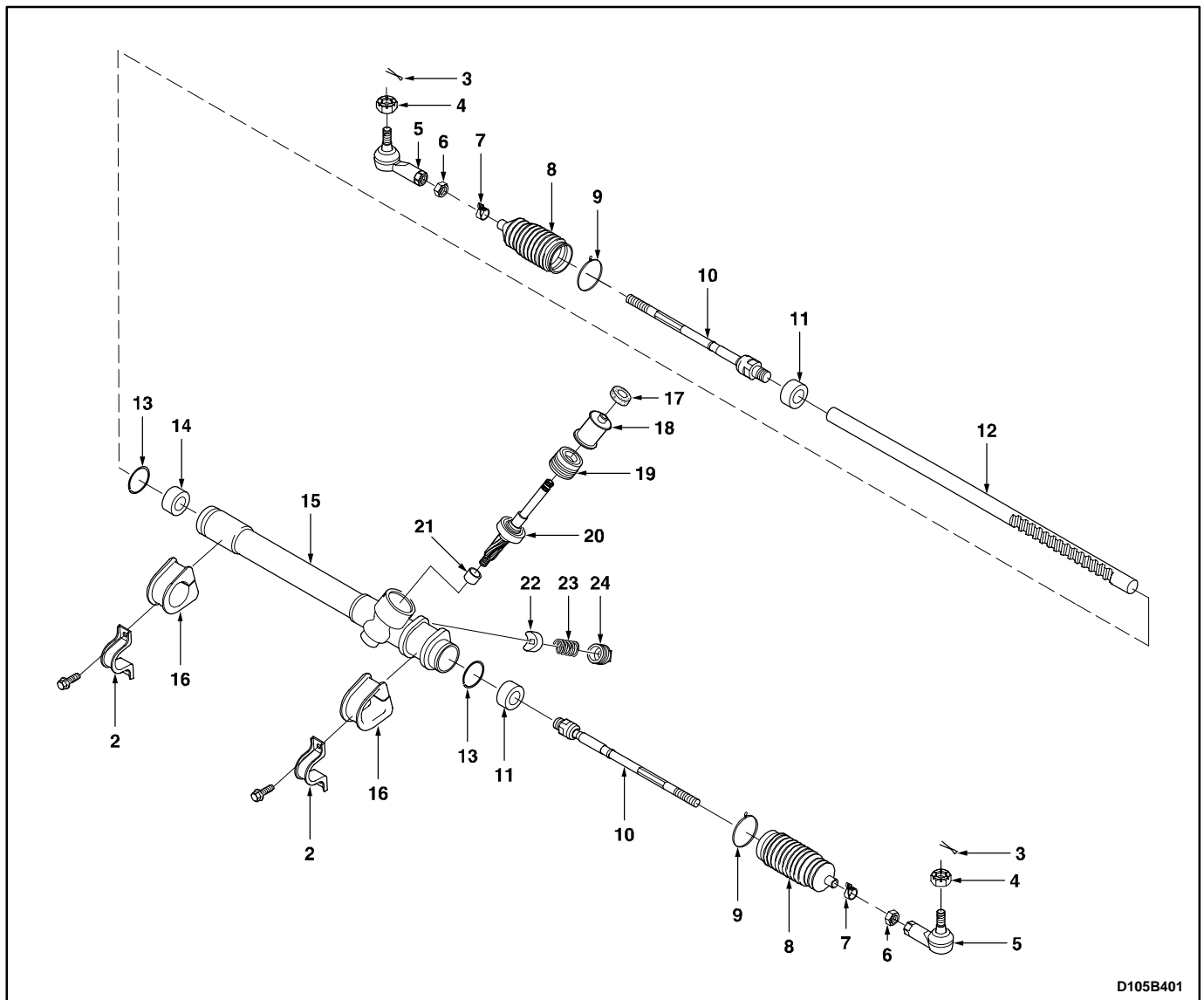

D105B401

- | | |
|------------------------------------|-----------------------------------|
| 1. Manual Steering Gear | 13. Bulkhead Retainer |
| 2. Steering Gear Bracket | 14. Bulkhead Bushing |
| 3. Cotter Pin | 15. Steering Gear Housing |
| 4. Castellated Nut | 16. Steering Gear Bracket Bushing |
| 5. Tie Rod End | 17. Packing |
| 6. Tie Rod End Lock Nut | 18. Dust Cover |
| 7. Rack and Pinion Boot Clamp | 19. Pinion Plug |
| 8. Rack and Pinion Boot | 20. Steering Pinion Gear |
| 9. Rack and Pinion Boot Wire Clamp | 21. Roller Bearing |
| 10. Tie Rod | 22. Rack Bearing |
| 11. Shock Damper Ring | 23. Adjuster Spring |
| 12. Steering Rack Gear | 24. Adjuster Plug |

DIAGNOSTIC INFORMATION AND PROCEDURES**MANUAL RACK AND PINION STEERING GEAR**

Condition	Probable Cause	Correction
Excessive Play or Looseness in the Steering System	● Poor adjustment of steering gear.	● Perform straight-ahead check.
	● Improperly installed tie rods.	● Tighten the tie rods.
Rattling Noise in the Steering Gear	● Improper and insufficient lubrication.	● Lubricate the rack and pinion assembly.
	● Improperly installed steering gear mounting.	● Tighten the steering gear mounting bolts.
	● Improperly installed tie rods.	● Tighten the tie rods.

STRAIGHT-AHEAD CHECK

After all the necessary operations on the steering gear are completed, check the exact straight-ahead position of the steering in each case.

With the vehicle on the floor, place the steering wheel in the straight-ahead position. Mark the centerline of both tires on the floor. Turn the steering wheel all the way to the right and mark the new centerline of both tires on the floor.

Application	Tire	Specified Valve
Inside Angle	145, 155	37.5 – 41.5°
	175	32.9 – 36.9°
Outside Angle	145, 155	31.5 – 35.5°
	175	28.5 – 32.5°

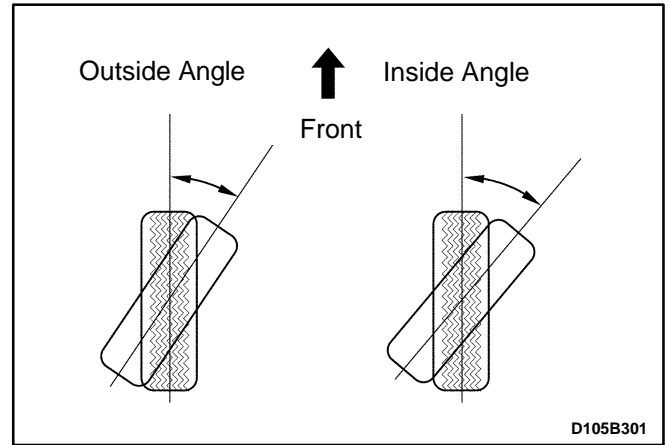

Straight Ahead Check Table

Step	Action	Value(s)	Yes	No
1	Place the steering wheel in the straight-ahead position. Is the wheel in the correct position?	–	Go to Step 2	–
2	Is the steering wheel off center by more than 5 degrees?	–	Go to Step 4	Go to Step 5
3	The pinion is displaced on the rack. The steering pinion position must be corrected. Is the repair complete?	–	Go to Step 2	–
4	Remove steering wheel and center on the spindle splines. Is the repair complete?	–	Go to Step 2	–
5	Turn the steering wheel all the way to the right. Measure the inner and the outer angles of the tire centerline compared to the straight-ahead centerline. Do the angles match the value specified?	Refer to “Straight-Ahead Check” in this section	System OK	Go to Step 6
6	The rack assembly was not assembled correctly. Repair as needed. Is the repair complete?	–	Go to Step 5	–

STEERING WHEEL RESTORATION

1. Turn the steering wheel fast to the right and left and turn it slowly as the same way.
2. Check if the steering wheel restoration for the wheel turning to right and the one to the left are same.
3. Turn the steering wheel to 90° about 1–2 seconds and loosen the steering wheel during the low speed driving.
4. If the steering wheel restores above 70%, the steering wheel restoration is OK.
5. If the restoration is poor, check the tire pressure, steering gear preload, and steering gear operation. And repair the fault.

CHECK THE TURNING RESISTANCE OF THE TIE ROD END OR TIE ROD

1. Turn the ball joint of the tie rod end or the tie rod about 10 times.
2. Use a spring balance to check the turning resistance of each ball joint.

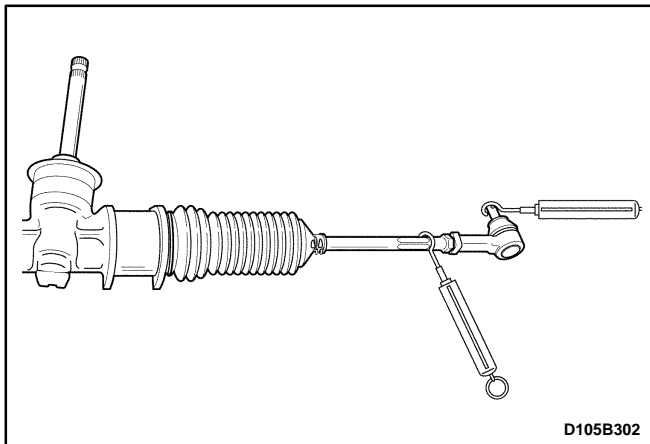

Application	Specified Value
Tie Rod End Ball Joint	0.49 – 3.43 N•m (4.5 – 30 lb-in.)
Tie Rod Ball Joint	0.49 – 3.43 N•m (4.5 – 30 lb-in.)

3. If the values exceed the specified values, replace the tie rod end or the tie rod.
4. But, If the ball joint of the tie rod end or the tie rod falls down of itself, replace it.

ADJUST THE FREE LOAD OF THE STEERING GEAR

1. Place the steering wheel in the straight-ahead position.
2. Raise and suitably support the vehicle.
3. Check the torque of the adjuster plug.
4. When the measured torque is below the specification value or the measured torque is over the specification value, adjust the tightening torque.
 - Place the rack gear in the straight-ahead position.
 - Tighten the adjust plug to 95 N•m (70 lb-ft).
 - Turn the steering wheel all the way to the right and the left about 5 times repeatedly.
 - Place the rack gear in the straight-ahead position.
 - Loosen the adjust plug.
 - Tighten the adjust plug to 8 N•m (71 lb-in.).
 - Set the torque in the 0.8–1.3 N•m (8–12 lb-in.) by loosening the adjust plug to 0° – 90°.

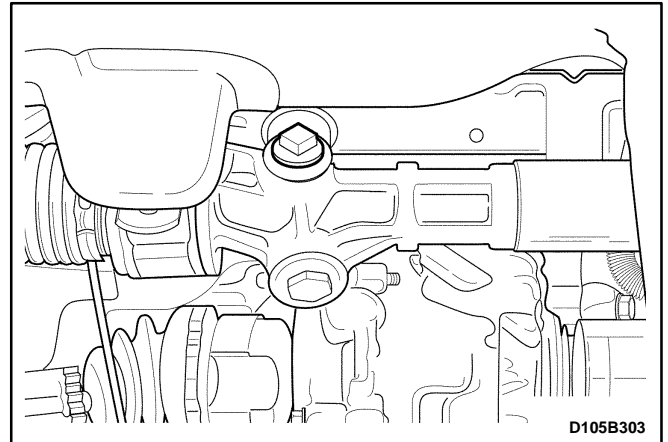

REPAIR INSTRUCTIONS

ON-VEHICLE SERVICE

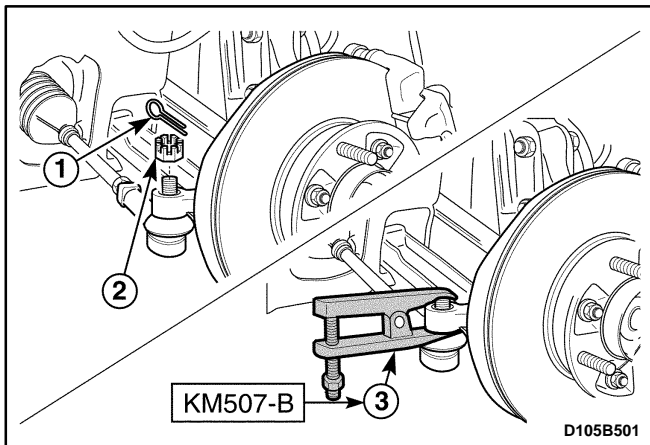

TIE ROD END

Tools Required

KM-507-B Ball Joint Remover

Removal Procedure

1. Remove the wheel. Refer to *Section 2E, Tires and wheels*.
2. Disconnect the tie rod and from the steering knuckle.
 - Remove the cotter pin (1).
 - Remove the castellated nut (2).
 - Use a ball joint remover KM-507-B, separate the tie rod end (3).
3. Remove the tie rod end.
 - Mark the tie rod, tie rod end lock nut and tie rod end (1).
 - Loosen the tie rod end lock nut anticlockwise (2).
 - Loosen the tie rod end (3).

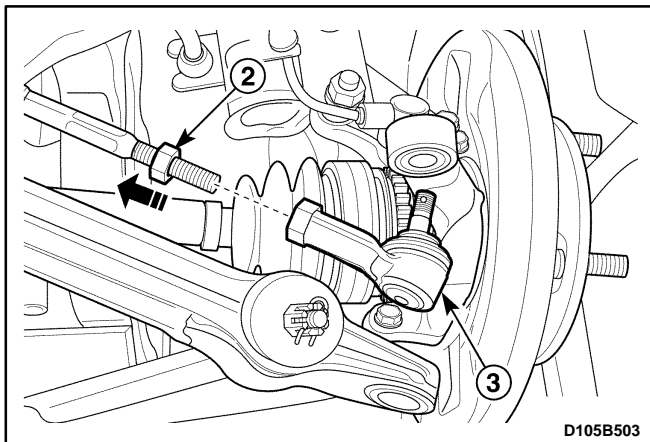
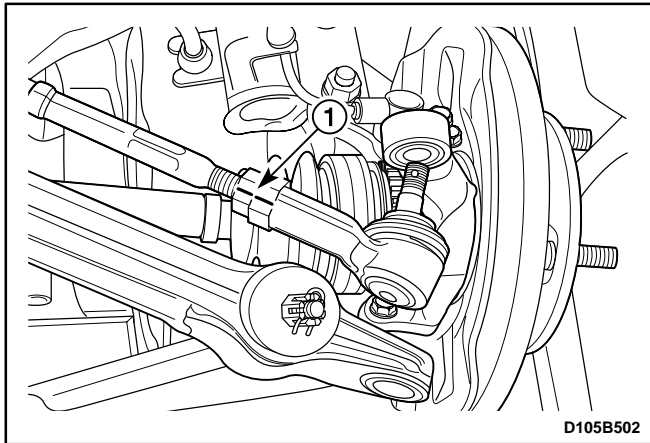

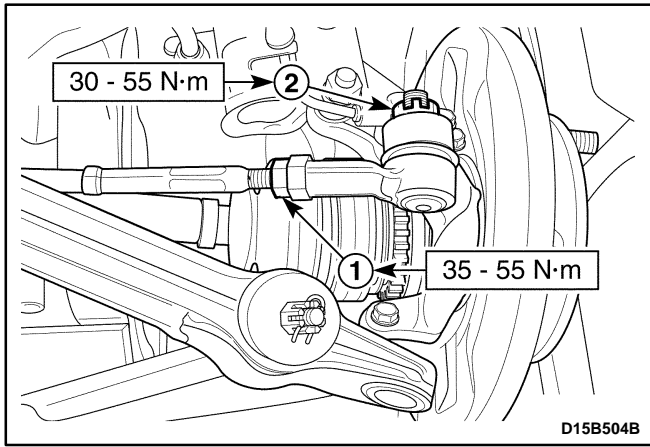

Installation Procedure

1. Install the tie rod end.
2. Install the tie rod lock nut (1).

Tighten

Tighten the tie rod end lock nut to 35–55 N•m (25–41 lb-ft).

3. Connect the tie rod end to the knuckle.
4. Install the tie rod end castellated nut (2).

Tighten

Tighten the castellated nut to 30–55 N•m (21–41 lb-ft).

5. Install the split pin.
6. Install the wheel. Refer to *Section 2E, Tires and Wheels*.
7. Make the toe-in adjustment by turning the tie rod adjuster. Refer to *Section 2B, Wheel Alignment*.

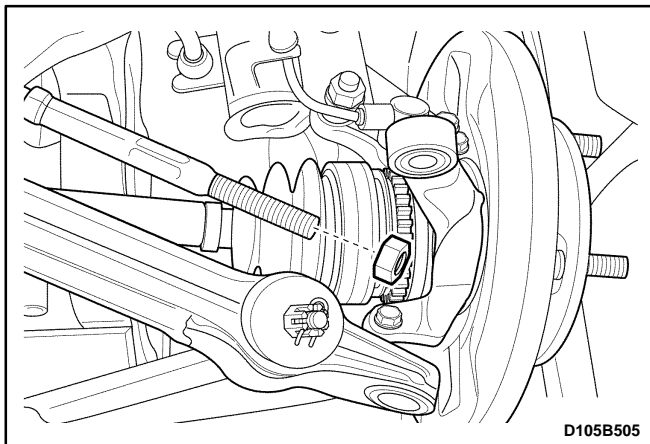

RACK AND PINION BOOT

Removal Procedure

1. Remove the tie rod end. Refer to “Tie Rod End” in this section.
2. Remove the tie rod end lock nut.

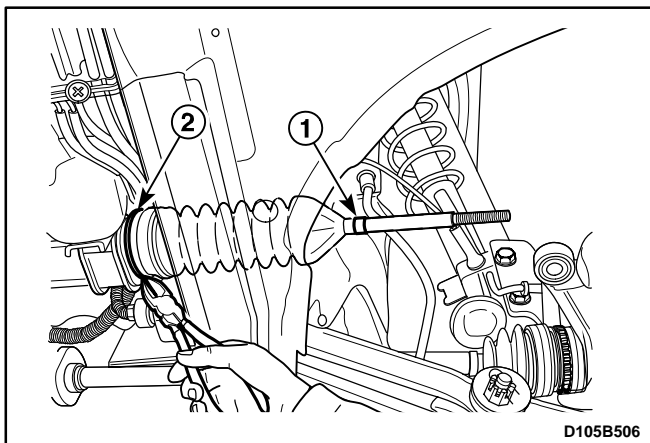

3. Remove the rack and pinion boot.
 - Remove the boot clamp (1).
 - Cut off the boot wire clamp (2).

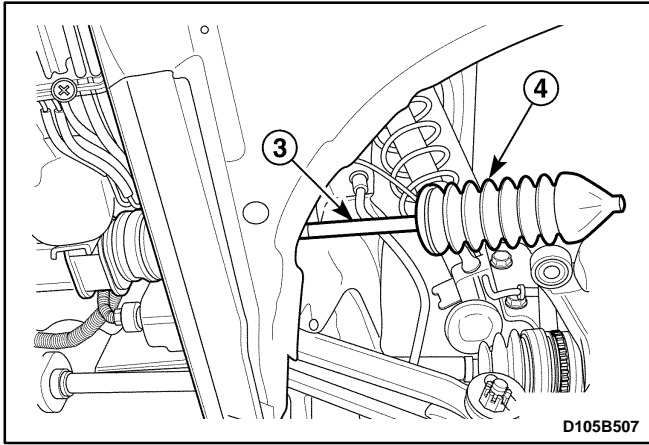

- Coat the greases on the tie rod to ease removal (3).
- Remove the boot (4).

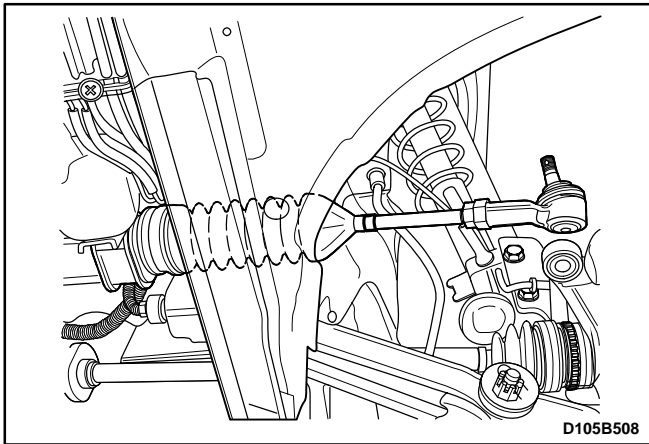

Installation Procedure

1. Install the rack and pinion boot with the clamp and the wire clamp.
2. Install the tie rod end nut.
3. Install the tie rod end. Refer to "Tie Rod End" in this section.

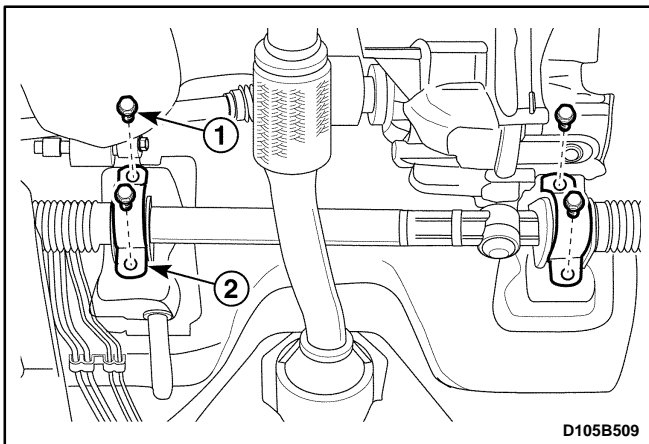

RACK AND PINION STEERING GEAR ASSEMBLY

(Left-Hand Drive Shown, Right-Hand Drive Similar)

Removal Procedure

1. Remove the intermediate shaft lower pinch bolt. Refer to *Section 6E, Steering Wheel and Column*.
2. Remove the wheels. Refer to *Section 2E, Tires and Wheels*.
3. Disconnect the tie rod end from the steering knuckle. Refer to "Tie Rod End" in this section.
4. Remove the front exhaust pipe nuts. Refer to *Section 1G, Engine Exhaust*.
5. Remove the steering gear assembly from the vehicle.
 - Remove the steering gear bracket bolts (1).
 - Remove the steering gear bracket (2).
 - Remove the steering gear assembly.
 - Remove the packing (3).

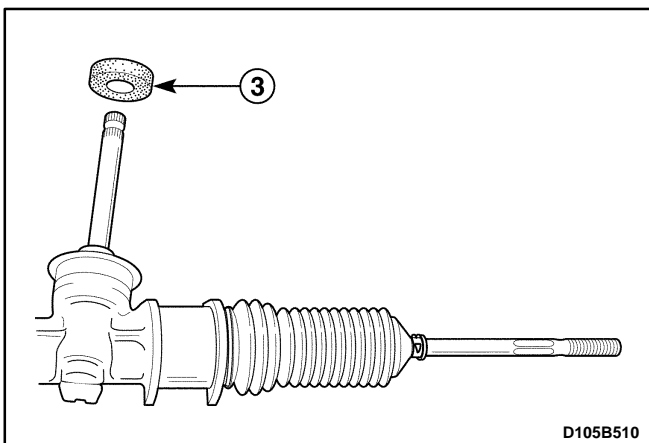

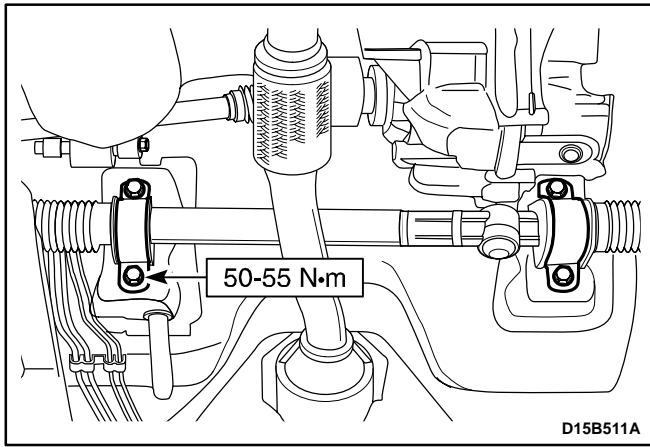

Installation Procedure

1. Install the mounting to the steering gear assembly.
2. Install the steering gear assembly.
3. Install the steering gear bracket with the bolts.

Tighten

Tighten the steering gear bracket bolts to 50–55 N•m (36–41 lb-ft).

4. Install the front exhaust pipe nuts. Refer to *Section 1G, Engine Exhaust*.
5. Connect the tie rod end to the steering knuckle. Refer to "Tie Rod End" in this section.
6. Install the wheels. Refer to *Section 2E, Tires and Wheels*.
7. Install the intermediate shaft lower pinch bolt. Refer to *Section 6E, Steering Wheel and Column*.

UNIT REPAIR

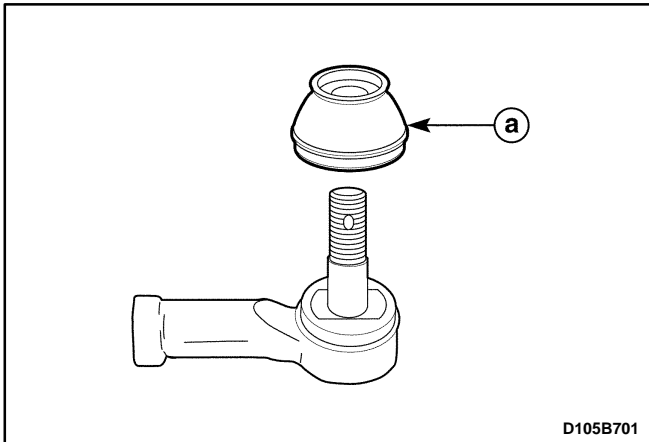

TIE ROD END BOOT

Disassembly Procedure

1. Remove the tie rod end. Refer to "Tie Rod End" in this section.
2. Remove the tie rod end boot.
 - a. Tie rod end boot.

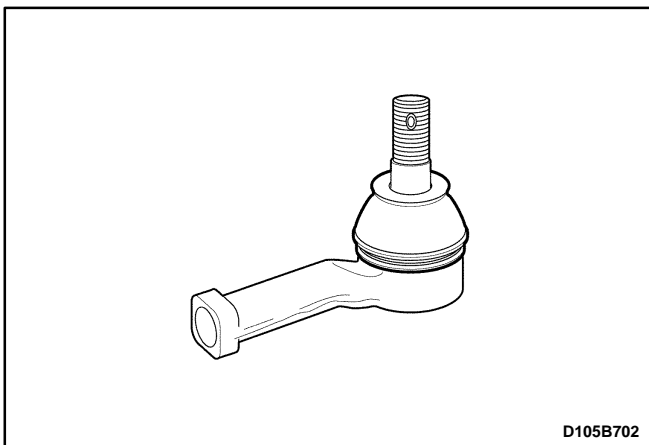

Assembly procedure

Important : Coat the grease inside of the boot.

1. Install the boot to the tie rod end.
2. Install the tie rod end wire clamp.
3. Install the tie rod end. Refer to "Tie Rod End" in this section.

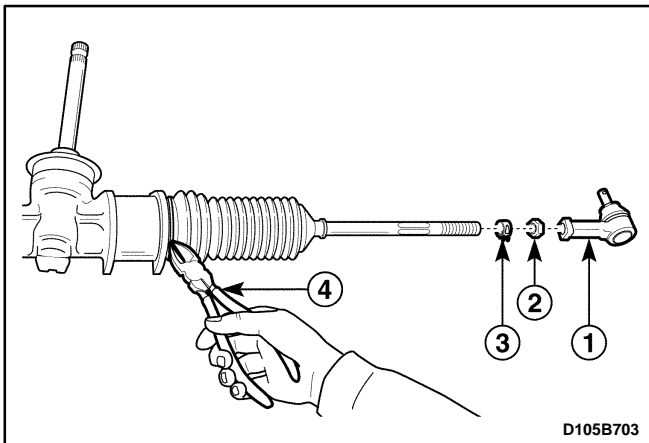

RACK AND PINION

(Left-Hand Drive Shown, Right-Hand Drive Similar)

Disassembly Procedure

1. Remove the rack and pinion steering assembly from the vehicle. Refer to "Rock and Pinion Assembly" in this section.
2. Remove the rack and pinion boot.
 - Remove the tie rod end. Refer to "Tie Rod End" in this section (1).
 - Remove the tie rod lock nut (2).
 - Remove the rack and pinion boot clamp (3).
 - Cut off the rack and pinion boot wire (4).

6D – 12 MANUAL STEERING GEAR

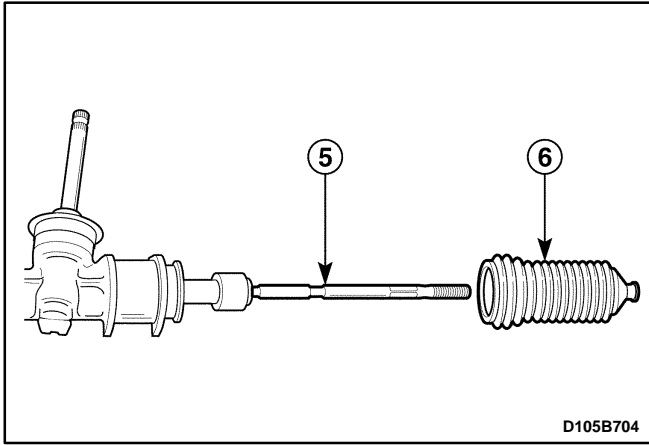

- Coat the greases on the tie rod (5).
- Remove the rack and pinion boot (6).

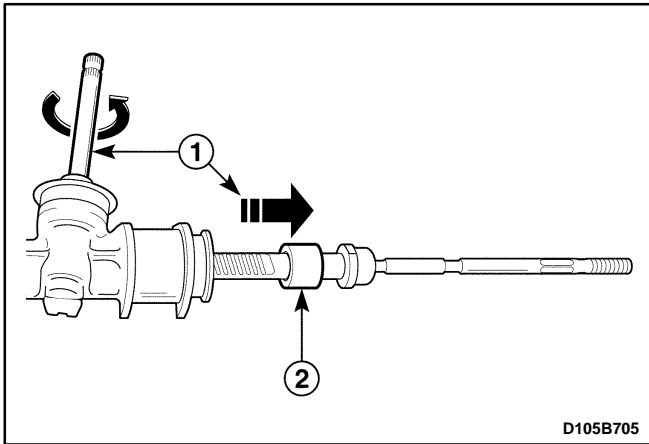

3. Remove the tie rod

- Pull the rack gear perfectly from the steering gear housing by turning the pinion gear (1).
- Disconnect the shock damper ring from the tie rod ball joint (2).

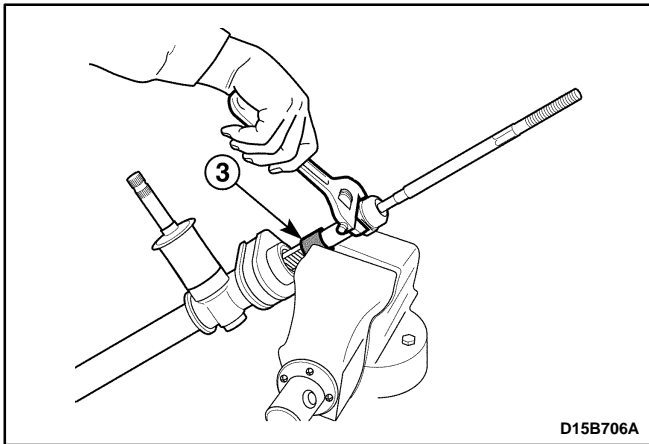

- Vise the rack gear (3).

Important: Cloth the rack gear with a cloth before vising the rack gear.

Notice: Do not vise the rack gear over two teeth face.

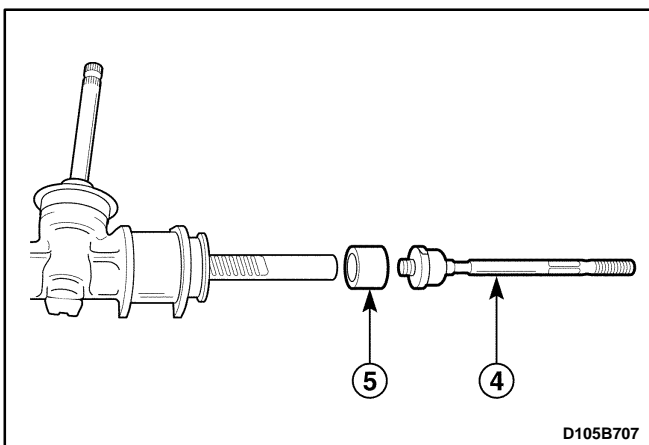

- Remove the tie rod (4).
- Remove the shock damper ring (5).

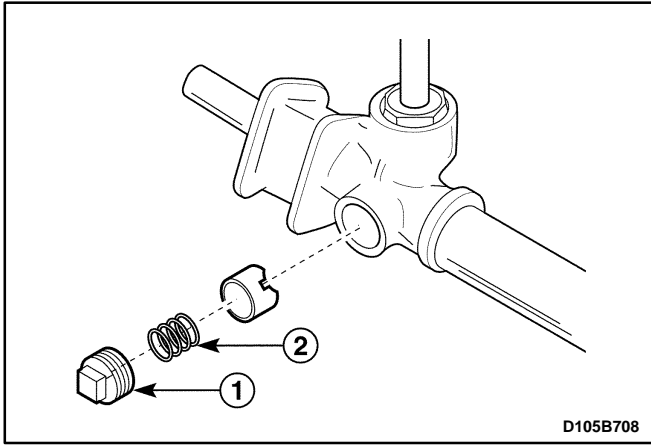

4. Remove the rack bearing.
- Remove the adjuster plug (1).
 - Remove the adjuster spring (2).

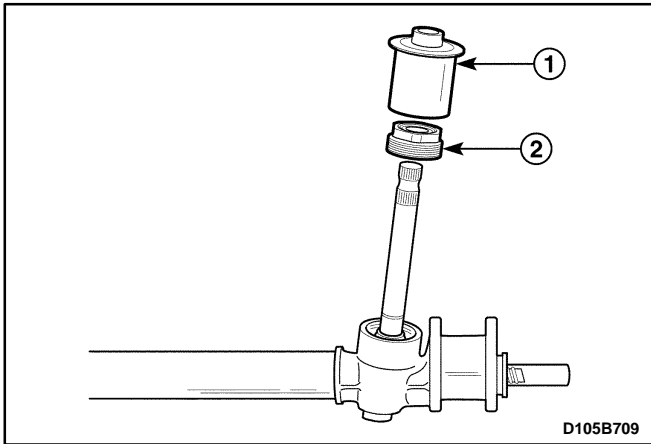

5. Remove the pinion and bearing assembly.
- Remove the dust cover (1).
 - Remove the pinion plug (2).

Important: Do not reuse the removed pinion plug.

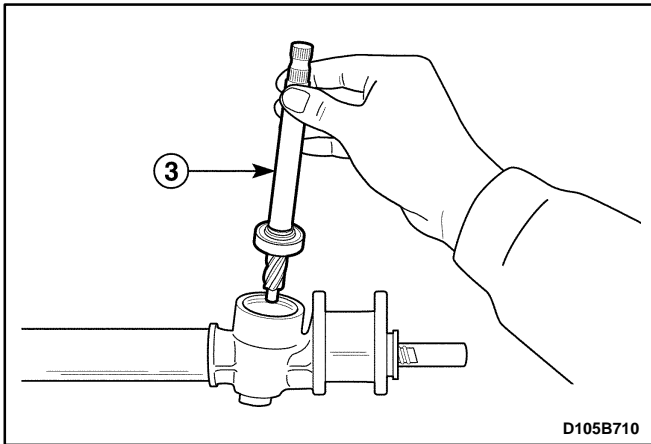

- Remove the pinion and bearing assembly (3).

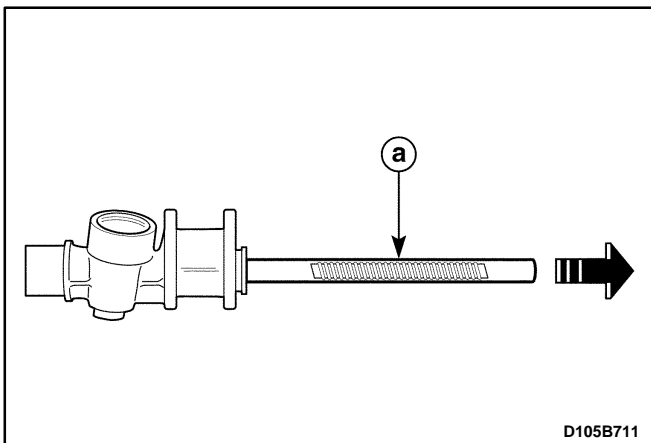

6. Remove the rack gear toward the driver side of the steering gear.
- a. Rack gear.

Notice: Remove the rack gear toward the driver side of the steering gear to prevent the bulk head in the steering gear housing from damaging in installing and removing the rack gear.

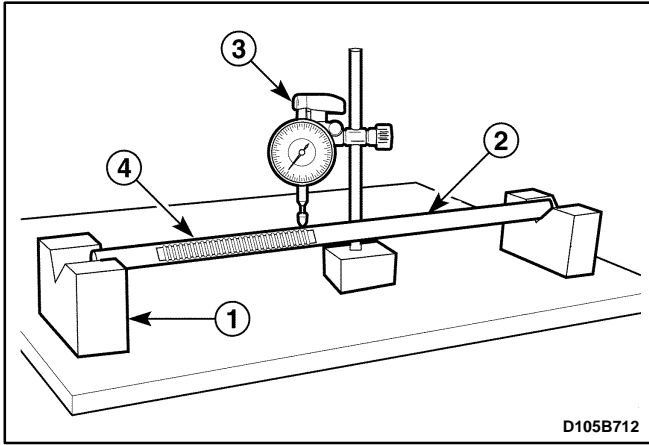

Inspection Procedure

1. Inspect the rack gear deformation and damage.
 - Set the V-block on the plate (1).
 - Set the rack gear on the V-block (2).
 - Check the rack gear for deformation using a dial gauge (3).
 - Inspect the rack gear for wear and damage (4).

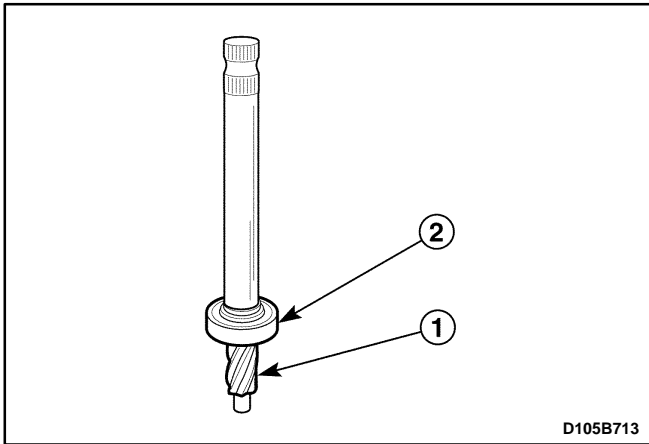

2. Inspect the pinion and bearing assembly damage.
 - Inspect the pinion gear for wear and damage (1).
 - Inspect the bearing for loose and operation (2).

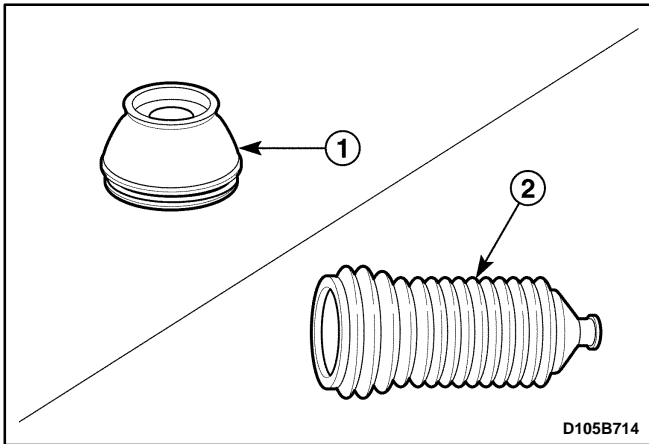

3. Inspect the tie rod end boot and the rack and pinion boot for damage.
 - Inspect the tie rod end boot for crack and wear (1).
 - Inspect the rack and pinion boot for crack and wear (2).

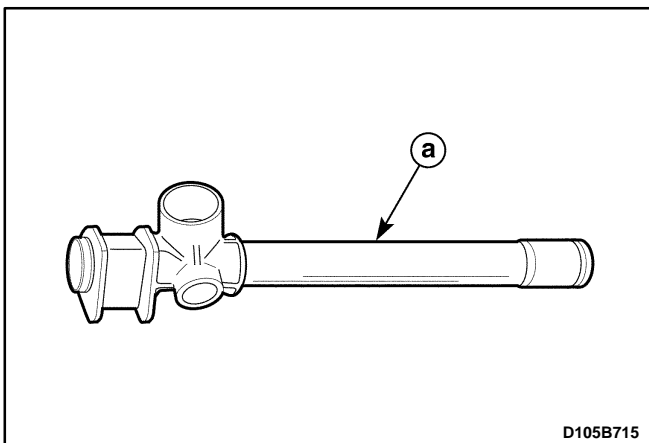

4. Inspect the steering gear housing for crack, deformation and wear.
 - a. Steering gear housing.

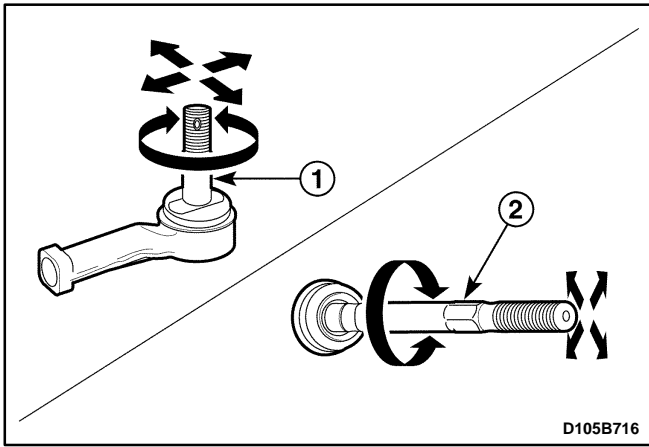

5. Inspect the tie rod end ball joint and tie rod ball joint for damage.
 - Inspect the tie rod end ball joint for operation (1).
 - Inspect the tie rod ball joint for operation and tie rod deformation (2).
6. After inspecting the parts, replace the defected parts.

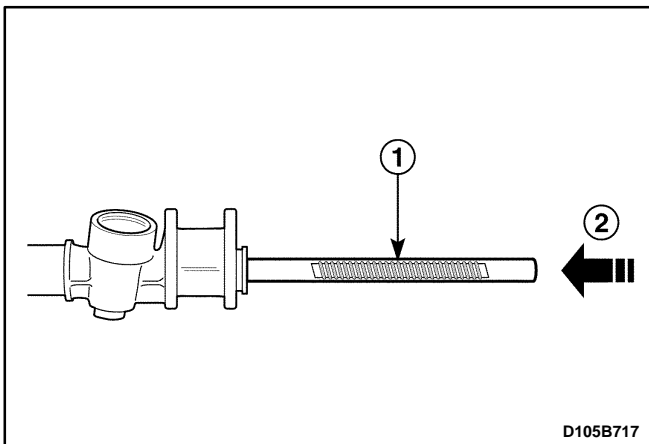

Assembly Procedure

Important: Coat the all turn, contact and rub surface with grease.

1. Clean the all parts removed.
2. Install the rack gear.
 - Coat the rack gear with grease (1).
 - Insert the rack gear carefully (2).

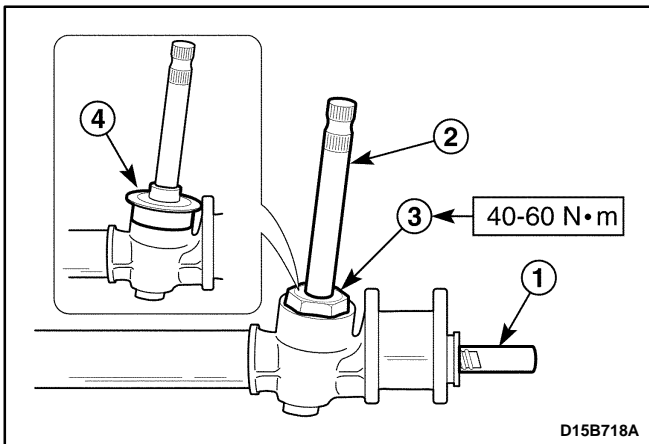

3. Install the pinion and bearing assembly.
 - Set the rack in balance (1).
 - Coat the pinion and bearing assembly and steering gear housing surface with grease.
 - Install the pinion and bearing assembly (2).
 - Coat the pinion plug with Loctite.
 - Install the pinion plug (3).

Tighten

Tighten the pinion plug to 40-60 N·m (30-44 lb-ft).

- Install the dust cover (4).

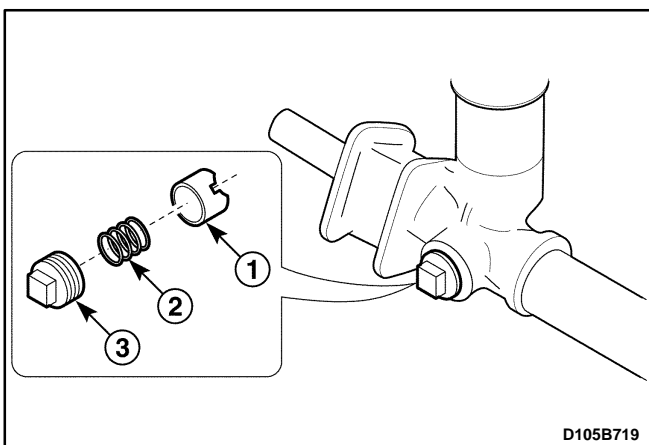

4. Install the rack bearing.
 - Coat the rack bearing with grease.
 - Install the rack bearing (1).
 - Install the adjuster spring (2).
 - Tighten the adjuster plug softly (3).

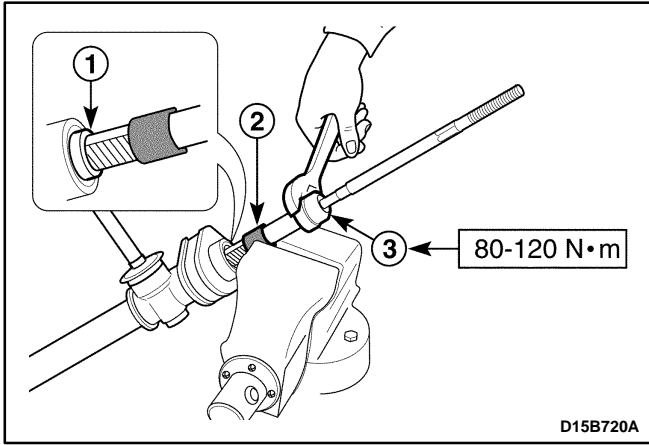

5. Install the tie rod.
 - Install the shock damper ring to the rack gear (1).
 - Vise the rack gear (2).

Important : Cloth the rack gear with a cloth before vising the rack gear.

Notice: Do not vise the rack gear above two teeth face.

- Coat the teeth face of the tie rod with Loctitte.
- Install the tie rod (3).

Tighten

Tighten the tie rod to 80–120 N•m (59–89 lb-ft).

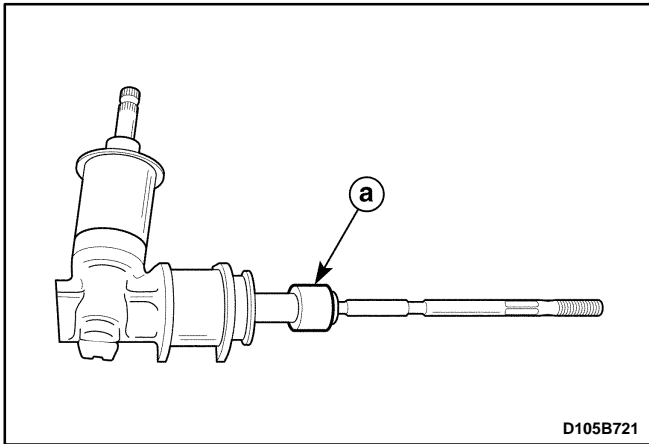

6. Install the shock damper ring to the tie rod ball joint.
 - a. Tie rod ball joint.
 - Coat the tie rod ball joint with grease.

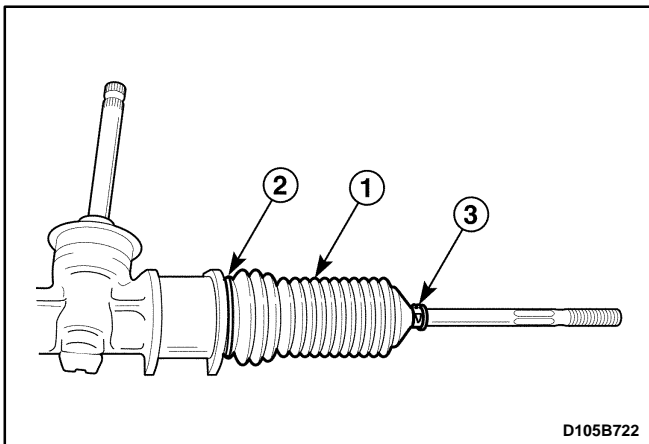

7. Install the rack and pinion boot.
 - Install the rack and pinion boot (1).
 - Install the rack and pinion boot wire clamp (2).
 - Install the rack and pinion boot clamp (3).
8. Install the tie rod end. Refer to “Tie Rod End” in this sections.
9. Install the rack and pinion steering gear assembly to the vehicle. Refer to “Rack and Pinion Steering Gear Assembly” in this section.
10. Adjust the free load of the steering gear. Refer to “Diagnosis” in this section.

SPECIFICATIONS

GENERAL SPECIFICATIONS

Application			Description
Type			Rack and Pinion
Overall Gear Ratio			21 : 1
Steering Angle	145,155 Tire	Inside	$39.5^{\circ} \pm 2^{\circ}$
		Outside	$33.5^{\circ} \pm 2^{\circ}$
	175 Tire	Inside	$34.9^{\circ} \pm 2^{\circ}$
		Outside	$30.5^{\circ} \pm 2^{\circ}$
Lubricant	Rack Gear		POLYUREAS
	Ball Joint		SYNTHETICS OILS & LI SOAPS
Locktite Type			DAC SPEC ADHESIVE SEALANT #520414

FASTENER TIGHTENING SPECIFICATIONS

Application	N•m	Lb-Ft	Lb-In
Tie Rod End Castellated Nut	30 – 55	21 – 41	–
Tie Rod End Lock Nut	35 – 55	25 – 41	–
Steering Gear Bracket Bolts	50 – 55	36 – 41	–
Tie Rod-to-Rack Gear	80 – 120	59 – 89	–
Pinion Plug	40 – 60	30 – 44	–
Pinion Preload	Refer to "Diagnosis" in this section.		

SPECIAL TOOLS AND EQUIPMENT

SPECIAL TOOLS TABLE

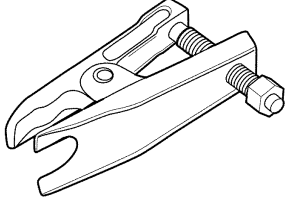
 <p data-bbox="381 598 462 619">D105B101</p>	<p data-bbox="519 420 763 483">KM-507-B Ball Joint Remover</p>
---	--

SECTION 6E

STEERING WHEEL AND COLUMN

CAUTION: *Disconnect the negative battery cable before removing or installing any electrical unit or when a tool or equipment could easily come in contact with exposed electrical terminals. Disconnecting this cable will help prevent personal injury and damage to the vehicle. The ignition must also be in B unless otherwise noted.*

TABLE OF CONTENTS

Description and Operation	6E-2	Ignition Lock Cylinder and Switch	
Steering Wheel and Column	6E-2	with Immobilizer	6E-9
Component Locator	6E-3	Switch Housing	6E-10
Steering Wheel and Column	6E-3	Steering Column	6E-11
Diagnostic Information and Procedures	6E-4	Intermediate Shaft cover and	
Steering Column Diagnosis	6E-4	Intermediate Shaft	6E-12
Repair Instructions	6E-7	Unit Repair	6E-13
On-Vehicle Service	6E-7	Standard Steering Column	6E-13
Steering Wheel	6E-7	Specifications	6E-15
Steering Column Cover	6E-8	General Specifications	6E-15
Turn Signal Switch and Lever/		Fastener Tightening Specifications	6E-15
Wiper Switch and Lever	6E-8	Special Tools and Equipment	6E-16
Ignition Switch	6E-9	Special Tools Table	6E-16

DESCRIPTION AND OPERATION

STEERING WHEEL AND COLUMN

In addition to the steering function, the steering column provides safety and security.

Caution: To ensure energy-absorbing action, it is important to use only the specified screws, bolts, and nuts, tightened to the specified torque.

The energy-absorbing column is designed to compress in a front-end collision to lessen the chance of driver injury.

The ignition switch and the lock are mounted on the column, allowing the ignition and steering operations to be locked to inhibit theft of the car.

The column levers trigger the turn signals, the headlight beams, and the windshield washer and wipers.

Notice: Apply a thin coat of lithium grease to all friction points when reassembling to ensure proper operation.

The column may be easily disassembled and assembled.

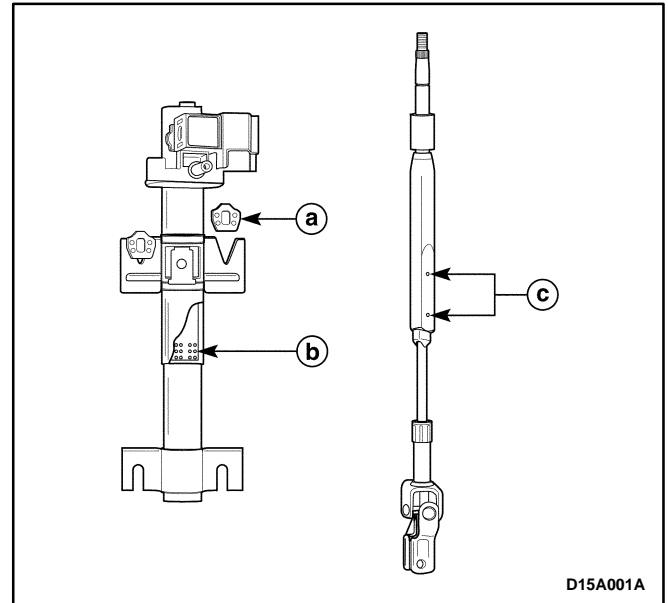

- Safety Device
 - A. Steering Column Upper Bracket.
 - B. Steering Column.
 - C. Steering Column Shaft.

COMPONENT LOCATOR

STEERING WHEEL AND COLUMN

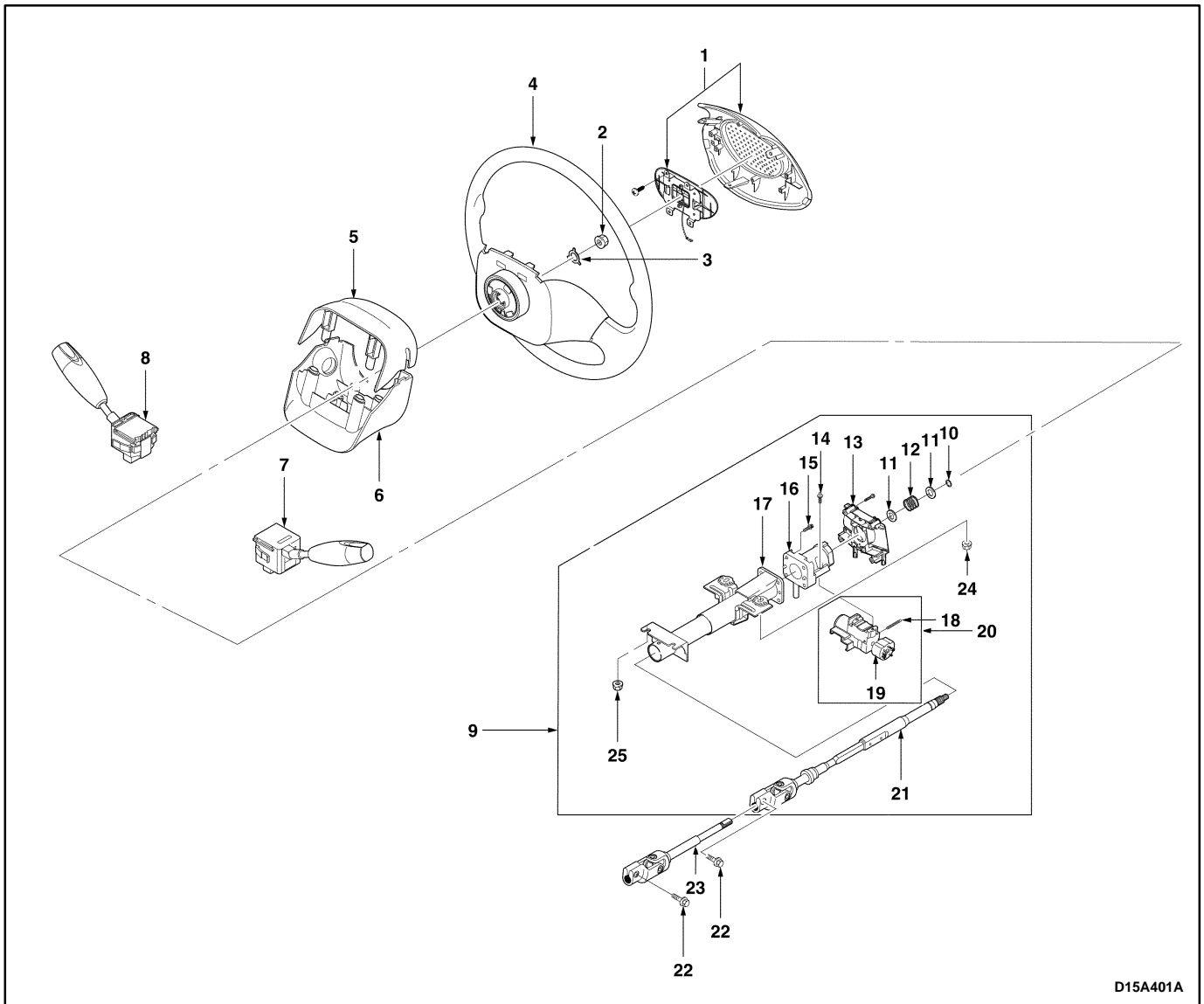

D15A401A

- | | |
|--------------------------------|-------------------------------------|
| 1. Horn Cover (Airbag Module) | 15. Support Bolt |
| 2. Steering Wheel Nut | 16. Steering Column Housing |
| 3. Locking Plate | 17. Steering Column Jacket |
| 4. Steering Wheel | 18. Ignition Switch Retaining Screw |
| 5. Steering Column Upper Cover | 19. Ignition Switch |
| 6. Steering Column Lower Cover | 20. Steering Lock Housing Assembly |
| 7. Turn Signal Switch | 21. Steering Column Shaft |
| 8. Windshield Wiper Switch | 22. Pinch Bolt |
| 9. Steering Column Assembly | 23. Intermediate Shaft |
| 10. Retaining Ring | 24. Steering Column Upper Nut |
| 11. Washer | 25. Steering Column Lower Nut |
| 12. Spring | |
| 13. Switch Housing | |
| 14. Bolt | |

DIAGNOSTIC INFORMATION AND PROCEDURES

STEERING COLUMN DIAGNOSIS

Lock System

Condition	Probable Cause	Correction
Lock System Will Not Unlock	<ul style="list-style-type: none"> ● Damaged lock cylinder. 	<ul style="list-style-type: none"> ● Replace the lock cylinder.
	<ul style="list-style-type: none"> ● The lack of free movement for the ignition switch. 	<ul style="list-style-type: none"> ● Lubricate the ignition switch.
	<ul style="list-style-type: none"> ● Improper binding or damaged steering column housing. 	<ul style="list-style-type: none"> ● Remove the steering shaft and clear the steering column housing. ● Replace the steering column housing as needed.
Lock System Will Not Lock	<ul style="list-style-type: none"> ● Damaged lock cylinder. 	<ul style="list-style-type: none"> ● Replace the lock cylinder.
	<ul style="list-style-type: none"> ● The lack of free movement for the ignition switch. 	<ul style="list-style-type: none"> ● Lubricate the ignition switch.
	<ul style="list-style-type: none"> ● Improper binding or damaged steering column housing. 	<ul style="list-style-type: none"> ● Remove the steering shaft and clear the steering column housing. ● Replace the steering column housing as needed.
High Lock Effort	<ul style="list-style-type: none"> ● Damaged lock cylinder. 	<ul style="list-style-type: none"> ● Replace the lock cylinder.
	<ul style="list-style-type: none"> ● The lack of free movement for the ignition switch. 	<ul style="list-style-type: none"> ● Lubricate the ignition switch.
	<ul style="list-style-type: none"> ● Extreme misalignment of the housing to the cover. 	<ul style="list-style-type: none"> ● Realign the cover on the housing. ● Replace the cover as needed.
Key Cannot Be Removed in the B Position	<ul style="list-style-type: none"> ● The ignition switch to be set incorrectly. 	<ul style="list-style-type: none"> ● Reset the ignition switch.
	<ul style="list-style-type: none"> ● Damaged lock cylinder. 	<ul style="list-style-type: none"> ● Replace the lock cylinder.

Column

Condition	Probable Cause	Correction
Noise in the Column	<ul style="list-style-type: none"> ● Improperly installed intermediate shaft-to-column joints. 	<ul style="list-style-type: none"> ● Tighten the coupling pinch bolts. ● Replace the intermediate shaft as needed.
	<ul style="list-style-type: none"> ● Column misalignment. 	<ul style="list-style-type: none"> ● Replace the alignment spacer.
	<ul style="list-style-type: none"> ● The lack of lubrication for the joint. 	<ul style="list-style-type: none"> ● Lubricate the joint.
	<ul style="list-style-type: none"> ● The lack of lubrication for the steering shaft. 	<ul style="list-style-type: none"> ● Lubricate the steering shaft bearing.
	<ul style="list-style-type: none"> ● Improperly seated shaft lock snap ring. 	<ul style="list-style-type: none"> ● Adjust the shaft lock snap ring. ● Replace the shaft lock snap ring as needed.
	<ul style="list-style-type: none"> ● Improperly installed intermediate shaft pinch bolt. 	<ul style="list-style-type: none"> ● Tighten the pinch bolt.
High Steering Shaft Effort	<ul style="list-style-type: none"> ● Column misalignment. 	<ul style="list-style-type: none"> ● Replace the alignment spacer.
	<ul style="list-style-type: none"> ● A damaged bearing. 	<ul style="list-style-type: none"> ● Replace the steering column housing.
	<ul style="list-style-type: none"> ● The lack of free movement for the steering shaft universal joint. 	<ul style="list-style-type: none"> ● Lubricate the steering shaft universal joint. ● Replace the steering column shaft as needed.

Column (Cont'd)

Condition	Probable Cause	Correction
Lash in the Steering Column	<ul style="list-style-type: none"> ● Improperly installed steering column bracket mounting nuts. 	<ul style="list-style-type: none"> ● Tighten the steering column bracket mounting nuts.
	<ul style="list-style-type: none"> ● Loose steering column housing-to-steering column jacket support bolts. 	<ul style="list-style-type: none"> ● Tighten the support bolts.
Loose Steering Wheel	<ul style="list-style-type: none"> ● The bearing to be seated incorrectly in the housing. 	<ul style="list-style-type: none"> ● Correctly seat the bearing. ● Replace the column housing as needed.
	<ul style="list-style-type: none"> ● Loose steering column housing support bolts. 	<ul style="list-style-type: none"> ● Tighten the steering column housing support bolts.

Turn Signal / Dimmer Switch

Condition	Probable Cause	Correction
Turn Signal Will Not Stay in the Turn Position	<ul style="list-style-type: none"> ● An improperly installed turn signal switch. 	<ul style="list-style-type: none"> ● Remove and inspect the turn signal switch. ● Reinstall the switch.
	<ul style="list-style-type: none"> ● The broken or missing components for the cancelling mechanism. 	<ul style="list-style-type: none"> ● Replace the turn signal switch.
	<ul style="list-style-type: none"> ● Foreign material in the turn signal switch housing. 	<ul style="list-style-type: none"> ● Remove any foreign material.
Turn Signal Will Not Cancel	<ul style="list-style-type: none"> ● Broken or missing components for the cancelling mechanism. 	<ul style="list-style-type: none"> ● Replace the turn signal switch.
Turn Signal/Dimmer Switch Difficult to Operate	<ul style="list-style-type: none"> ● Improperly installed turn signal/dimmer switch and turn signal/dimmer switch lever. 	<ul style="list-style-type: none"> ● Remove and inspect the turn signal/dimmer switch and signal/dimmer switch lever. ● Reinstall the signal/dimmer switch and signal/dimmer switch lever.
	<ul style="list-style-type: none"> ● Foreign material in the signal/dimmer switch housing. 	<ul style="list-style-type: none"> ● Remove any foreign material.
Turn Signal Will Not Indicate Lane Change	<ul style="list-style-type: none"> ● A broken lane change pressure pad or a broken spring hanger. 	<ul style="list-style-type: none"> ● Replace the turn signal switch.
	<ul style="list-style-type: none"> ● The improper functioning of the lane change spring. 	<ul style="list-style-type: none"> ● Replace the turn signal switch.
	<ul style="list-style-type: none"> ● Improperly installed turn signal switch. 	<ul style="list-style-type: none"> ● Replace the turn signal switch.
No Turn Signal Lamps	<ul style="list-style-type: none"> ● An inoperative turn signal flasher. 	<ul style="list-style-type: none"> ● Replace the blinker unit.
	<ul style="list-style-type: none"> ● A faulty turn signal switch. 	<ul style="list-style-type: none"> ● Replace the turn signal switch.
	<ul style="list-style-type: none"> ● Improperly connected chassis-to-column connector. 	<ul style="list-style-type: none"> ● Reconnect the chassis-to-column connector.
Turn Indicator Lamps On, But Not Flashing	<ul style="list-style-type: none"> ● An inoperative blinker unit. 	<ul style="list-style-type: none"> ● Replace the blinker unit.
Front or Rear Turn Signal Lamps Not Flashing	<ul style="list-style-type: none"> ● An inoperative blinker unit. 	<ul style="list-style-type: none"> ● Replace the blinker unit.
Turn Signal Lamps Flash Very Slowly	<ul style="list-style-type: none"> ● An inoperative blinker unit. 	<ul style="list-style-type: none"> ● Replace the blinker unit.

Ignition Switch

Condition	Probable Cause	Correction
Electrical System Will Not Function	<ul style="list-style-type: none"> ● Damaged ignition switch. 	<ul style="list-style-type: none"> ● Replace the ignition switch.
	<ul style="list-style-type: none"> ● Improperly installed ignition switch. 	<ul style="list-style-type: none"> ● Remove and inspect the ignition switch. ● Reinstall the ignition switch.
	<ul style="list-style-type: none"> ● Improperly installed ignition switch electrical connector. 	<ul style="list-style-type: none"> ● Reconnect the ignition switch electrical connector. ● Replace the ignition switch electrical connector.
Ignition Switch Will Not Turn	<ul style="list-style-type: none"> ● Damaged ignition switch. 	<ul style="list-style-type: none"> ● Replace the ignition switch.
	<ul style="list-style-type: none"> ● Improperly installed ignition switch. 	<ul style="list-style-type: none"> ● Remove and inspect the ignition switch. ● Reinstall the ignition switch.

Wiper Switch Lever

Condition	Probable Cause	Correction
Switch Inoperative : No I, Low, High, Int or Wash	<ul style="list-style-type: none"> ● Damaged wiper switch. 	<ul style="list-style-type: none"> ● Replace the wiper switch.
	<ul style="list-style-type: none"> ● Improperly installed wiper switch. 	<ul style="list-style-type: none"> ● Remove and inspect the wiper switch. ● Reinstall the wiper switch.

REPAIR INSTRUCTIONS

ON-VEHICLE SERVICE

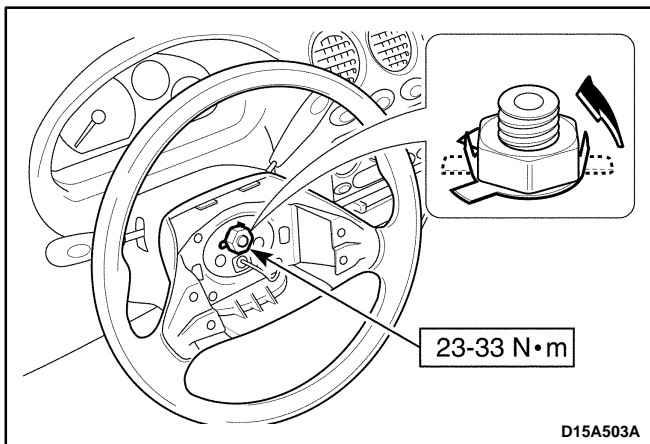
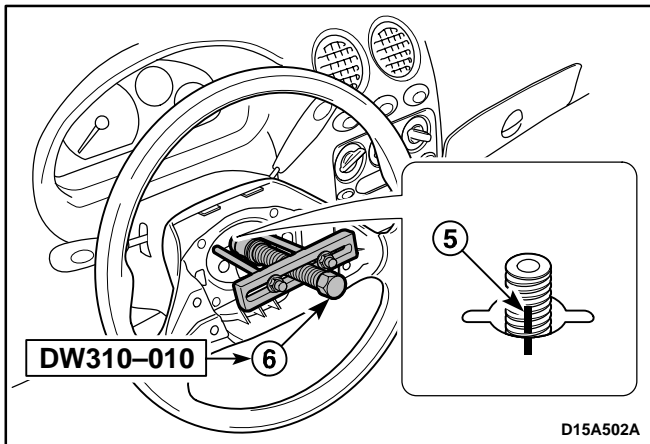

STEERING WHEEL

(Left-Hand Drive Shown, Right-Hand Drive Similar)

Tools Required

DW310-010, Steering Wheel Puller

Removal Procedure

1. Disconnect the negative battery cable.
2. Remove the SIR module. Refer to *Section 8B, Supplemental Inflatable Restraints*. (For vehicle with SIR)
3. Remove the steering wheel.
4. Remove the steering wheel horn cover (For vehicle without SIR) (1).
 - Straighten the bending locking plate (2).
 - Remove the nut (3).
 - Remove the locking plate (4).
 - In order to install the steering wheel correctly, match-mark the steering column shaft to the steering wheel (5).
 - Remove the steering wheel using the steering wheel puller DW310-010 (6).

Important: Be careful not to hit the top of steering column shaft with hammer during repair work.

Installation Procedure

1. Install the SIR module. Refer to *Section 8B, Supplemental Inflatable Restraints* (For vehicle with SIR).

Important: Align the match marks on the steering wheel and the steering column shaft.

2. Install the steering wheel with the nut and the locking plate.

Tighten

Tighten the steering wheel nut to 23-33 N·m (17-24 lb-ft).

3. Bend the tabs to secure the locking plate.
4. Install the steering wheel horn cover (For vehicle without SIR).
5. Connect the negative battery cable.

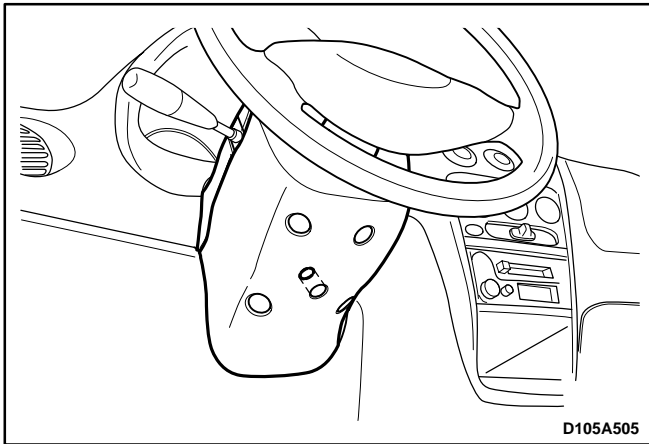
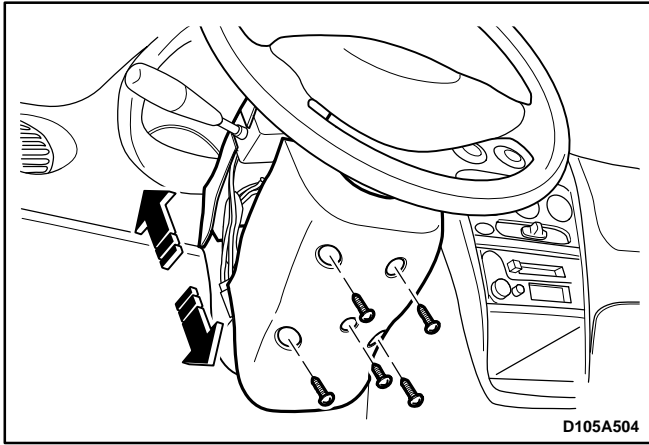

STEERING COLUMN COVER
(Left-Hand Drive Shown, Right-Hand Drive Similar)
Removal Procedure

1. Remove the screws.
2. Remove the steering column lower and upper cover.

Installation Procedure

1. Install the steering column lower and upper cover with the screws.

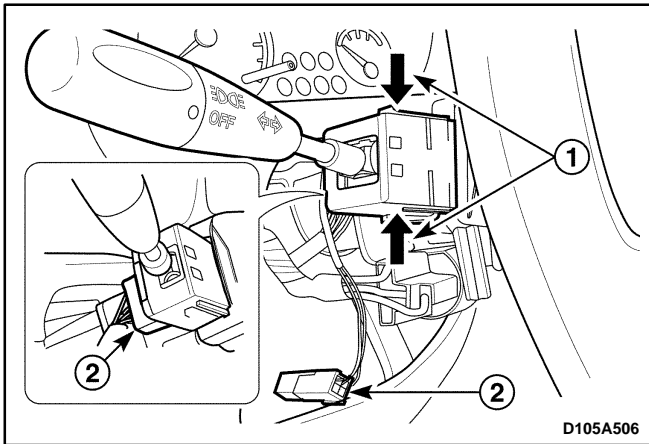

**TURN SIGNAL SWITCH AND LEVER/
WIPER SWITCH AND LEVER**
(Left-Hand Drive Shown, Right-Hand Drive Similar)
Removal Procedure

1. Disconnect the negative battery cable.
2. Remove the steering column cover. Refer to "Steering Column Cover" in this section.
3. Remove the turn signal switch.
 - Disconnect the turn signal switch by pushing the locking from the switch housing (1).
 - Disconnect the connector (2).

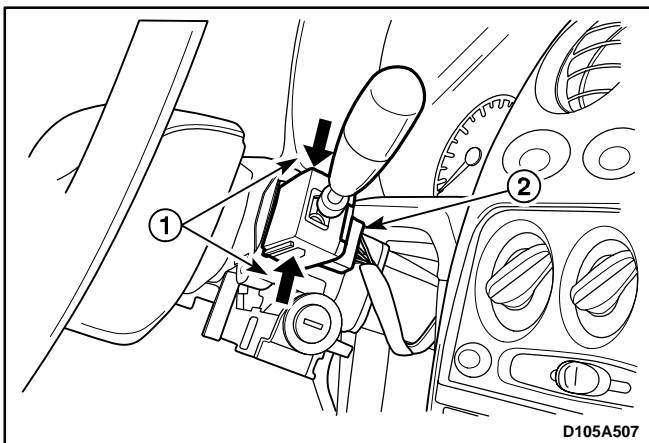

4. Remove the wiper switch.
 - Disconnect the wiper switch by pushing the locking from the switch housing (1).
 - Disconnect the connector (2).

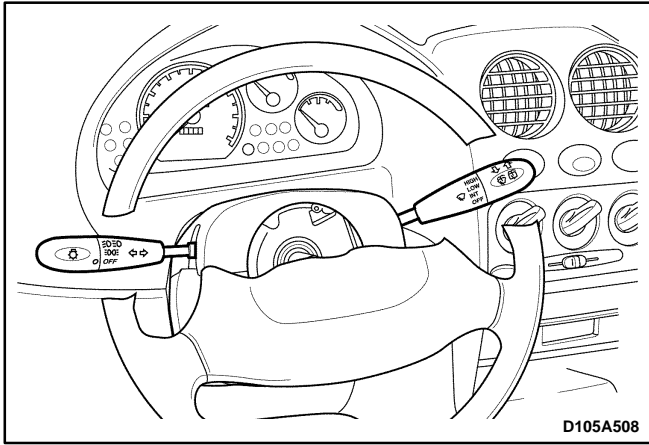

Installation Procedure

1. Install the wiper switch.
2. Install the turn signal switch.
3. Install the steering column cover. Refer to "Steering Column Cover" in this section.
4. Connect the negative battery cable.

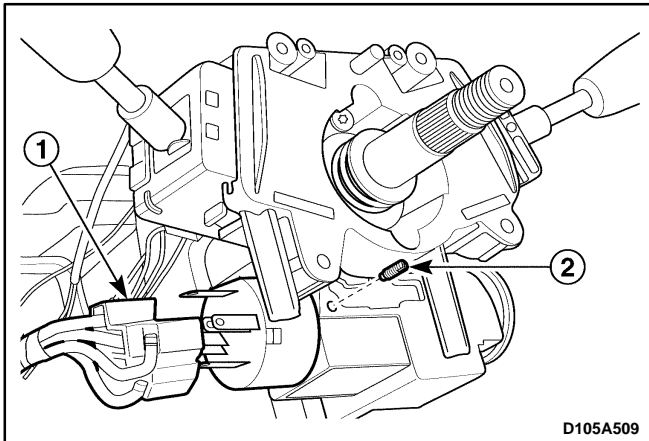

IGNITION SWITCH

Removal Procedure

1. Disconnect the negative battery cable.
2. Remove the steering wheel. Refer to "Steering Wheel" in this section.
3. Remove the ignition switch.
 - Disconnect the electrical connector (1).
 - Remove the screw (2).

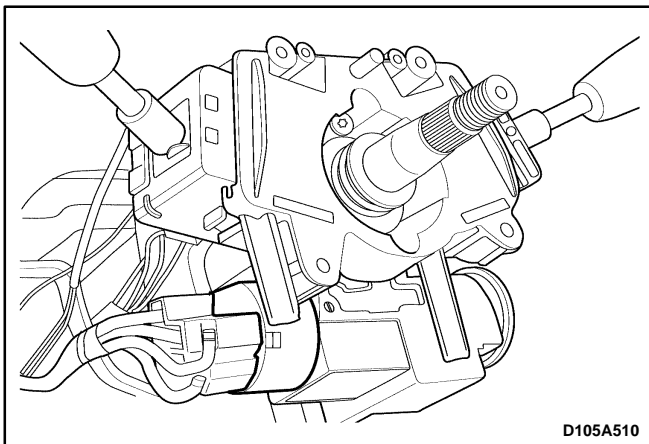

Installation Procedure

1. Connect the electrical connector.
2. Install the ignition switch with the screw.
3. Install the steering wheel. Refer to "Steering Wheel" in this section.
4. Connect the negative battery cable.

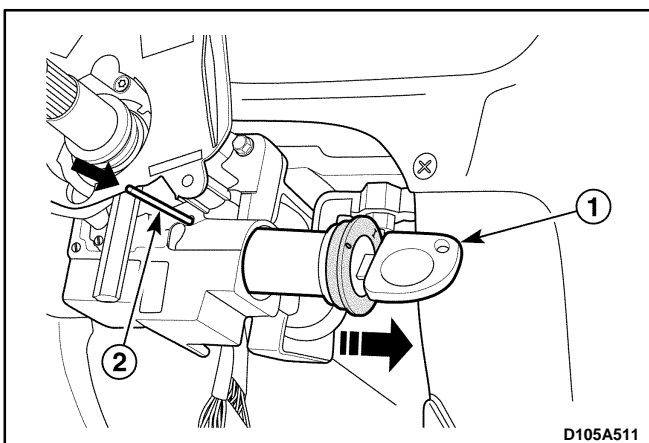

IGNITION LOCK CYLINDER WITH IMMOBILIZER

(Left-Hand Drive Shown, Right-Hand Drive Similar)

Removal Procedure

1. Remove the steering wheel. Refer to "Steering Wheel" in this section.
2. Disconnect the electrical connector for the immobilizer detection coil.
3. Remove the lock cylinder.
 - With the key in the ignition, turn to the position designated I (1).

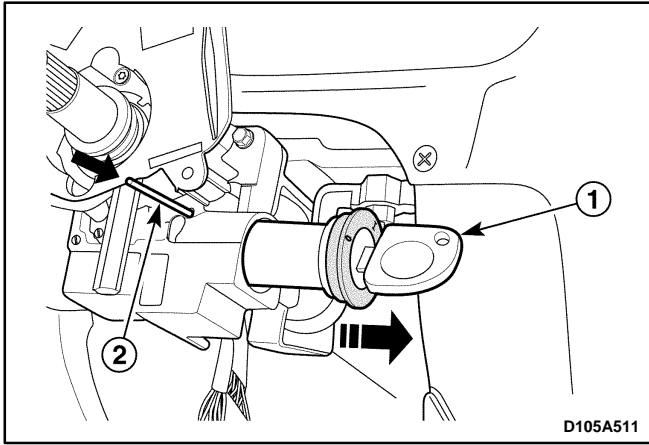

- Remove the lock cylinder by pressing down the detent spring with a 2.5MM allen wrench, or other suitable tool, and pulling the lock cylinder out of the switch cylinder housing (2).

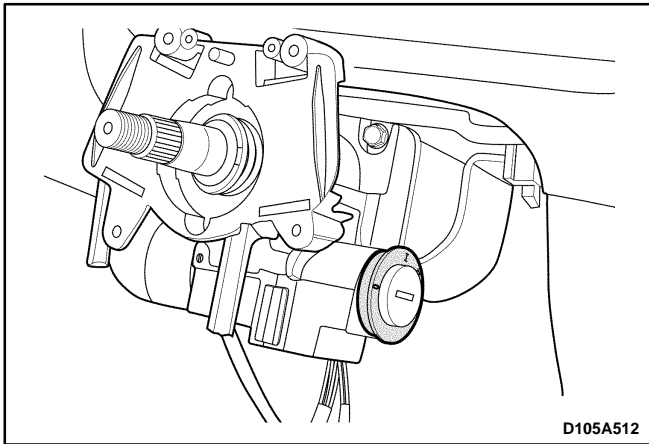

Installation Procedure

Important: To install the ignition lock cylinder the ignition position should be designated I.

1. Install the ignition lock cylinder.
2. Connect the electrical connector for the immobilizer detection coil.
3. Install the steering wheel. Refer to "Steering Wheel" in this section.

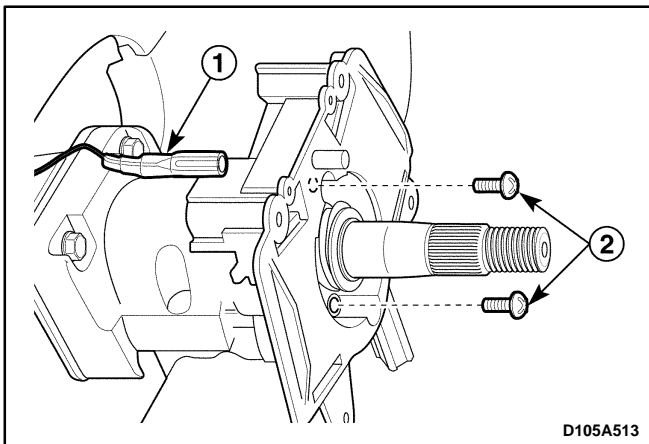

SWITCH HOUSING

(Left-Hand Drive Shown, Right-Hand Drive Similar)

Removal Procedure

1. Remove the steering wheel. Refer to "Steering Wheel" in this section.
2. Remove the turn signal switch and windshield wiper switch. Refer to "Turn Signal Switch and Lever/Wiper Switch and Lever" in this section.
3. Remove the switch housing.
 - Disconnect the horn electrical connector (1).
 - Remove the screws retaining the switch housing (2).

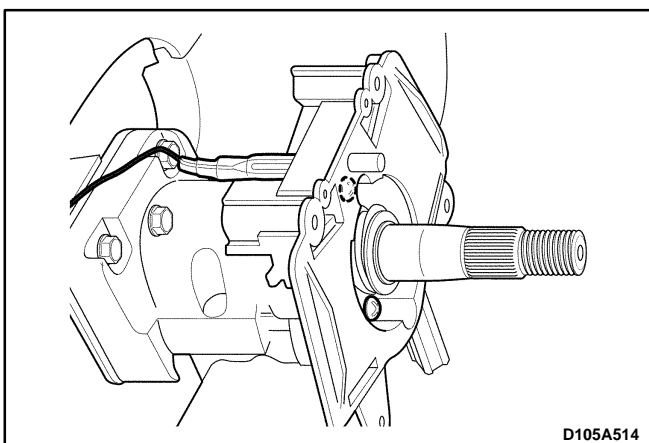

Installation Procedure

1. Install the switch housing with the screws.
2. Connect the horn electrical connector.
3. Install the turn signal switch and windshield wiper switch. Refer to "Turn Signal Switch and Lever/Wiper switch and Lever" in this section.
4. Install the steering wheel. Refer to "Steering Wheel" in this section.

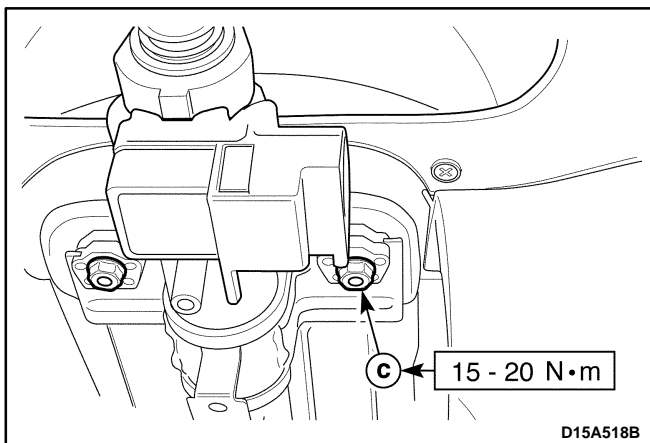
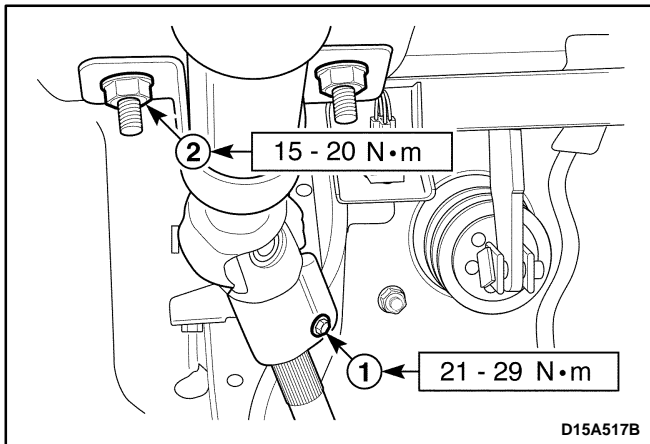
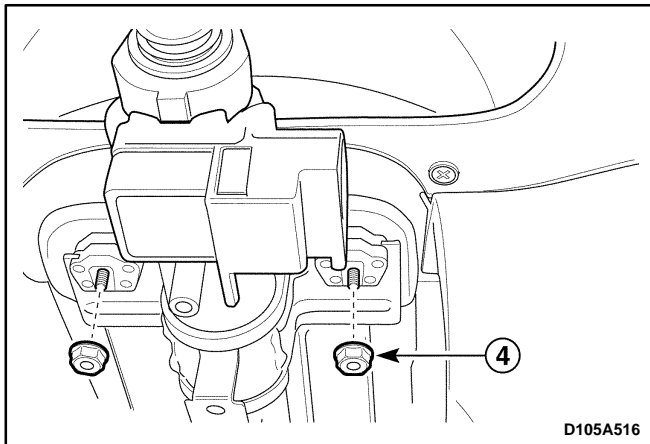
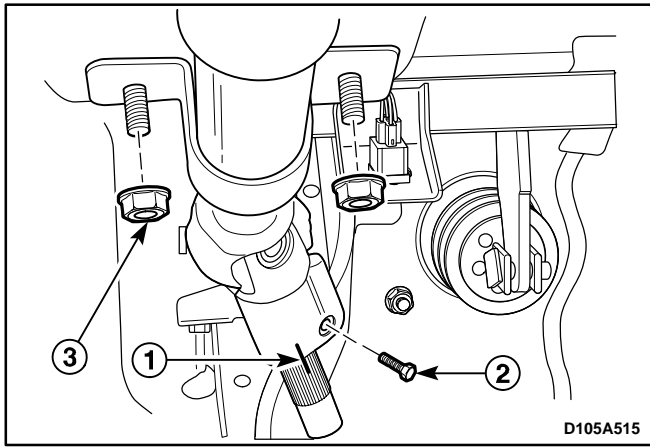

STEERING COLUMN

(Left-Hand Drive Shown, Right-Hand Drive Similar)

Removal Procedure

1. Remove the steering wheel. Refer to “Steering Wheel” in this section.

Caution: *Disconnect the negative battery cable and let the vehicle sit for 1 minute to deactivate the air-bag (For vehicle with SIR)*

2. Remove the turn signal switch and wiper switch. Refer to “Turn Signal Switch and Lever/Wiper Switch and Lever” in this section.

3. Remove the switch housing. Refer to “Switch Housing” in this section.

4. Remove the ignition switch. Refer to “Ignition Switch” in this section.

5. Remove the ignition lock cylinder. Refer to “Ignition Lock Cylinder” in this section.

6. Remove the steering column.

- Match-mark on the intermediate shaft and the steering column shaft (1).
- Remove the intermediate shaft upper pinch bolt (2).
- Remove the steering column lower nuts (3).
- Remove the steering column upper nuts (4).

Installation Procedure

Important: Align the match-mark on the intermediate shaft and the steering column shaft.

1. Install the steering column.

- Install the intermediate shaft upper pinch bolt (1).

Tighten

Tighten the pinch bolt to 21–29 N·m (16–22 lb-ft).

- Install the steering column lower nuts (2).

Tighten

Tighten the nuts to 15–20 N·m (11–15 lb-ft).

- Install the steering column upper nuts (3).

Tighten

Tighten the nuts to 15–20 N·m (11–15 lb-ft).

2. Install the ignition lock cylinder. Refer to “Ignition Lock Cylinder” in this section.

3. Install the ignition switch. Refer to “Ignition Switch” in this section.

4. Install the switch housing. Refer to “Switch Housing” in this section.

5. Install the turn signal switch and wiper switch. Refer to “Turn Signal Switch and Lever/Wiper Switch and Lever” in this section.

6. Install the steering wheel. Refer to “Steering Wheel” in this section.

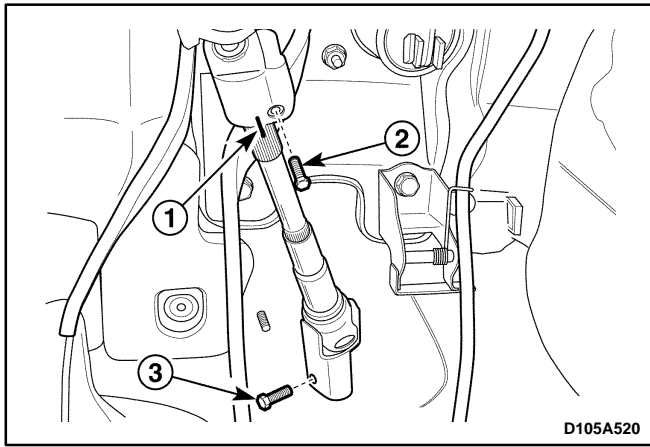

INTERMEDIATE SHAFT COVER AND INTERMEDIATE SHAFT

(Left-Hand Drive Shown, Right-Hand Drive Similar)

Removal Procedure

1. Remove the intermediate shaft.
 - In order to install the intermediate shaft correctly, match-mark the intermediate shaft to the steering column. (1).
 - Remove the intermediate shaft upper pinch bolt (2).
 - Remove the intermediate shaft lower pinch bolt (3).

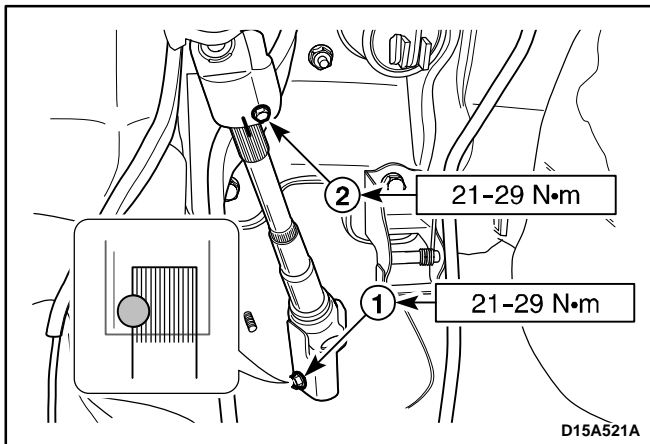

Installation Procedure

1. Install the intermediate shaft with the bolts.

Tighten

- Tighten the intermediate shaft lower pinch bolt to 21–29 N•m (16–22 lb-ft) (1).
- Tighten the intermediate shaft upper pinch bolt to 21–29 N•m (16–22 lb-ft) (2).

Notice: Check the lower pinch bolt position correctly.

UNIT REPAIR

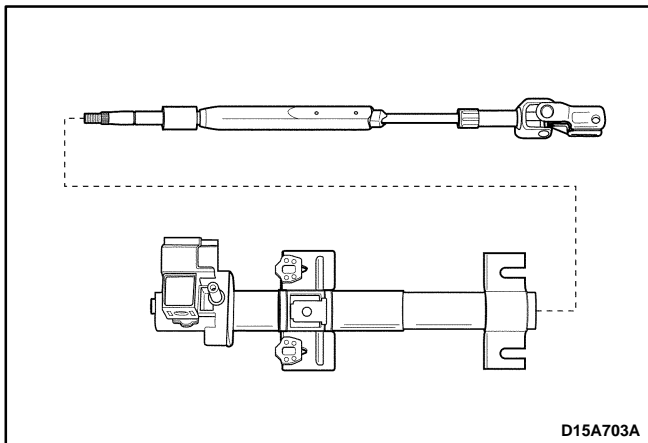
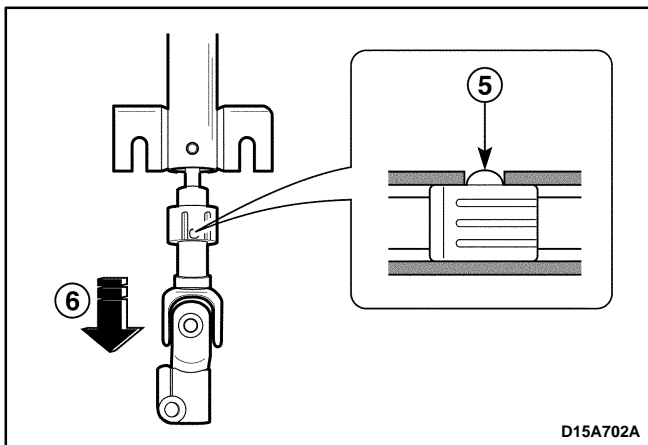
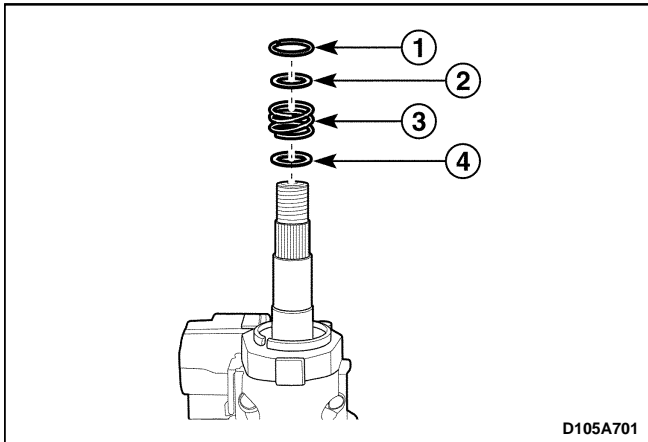

STANDARD STEERING COLUMN

Disassembly Procedure

1. Remove the steering column from the vehicle. Refer to "Steering Column" in this section.

Caution: *Be careful not to impact on the steering column shaft. Plastic sleeve may be broken that is installed to secure the driver at the accident.*

2. Remove the steering column shaft from the steering column.

- Remove the retaining ring (1).
- Remove the washer (2).
- Remove the spring (3).
- Remove the washer (4).
- Remove the locking of the alignment spacer (5).
- Push strongly the steering column shaft downward (6).

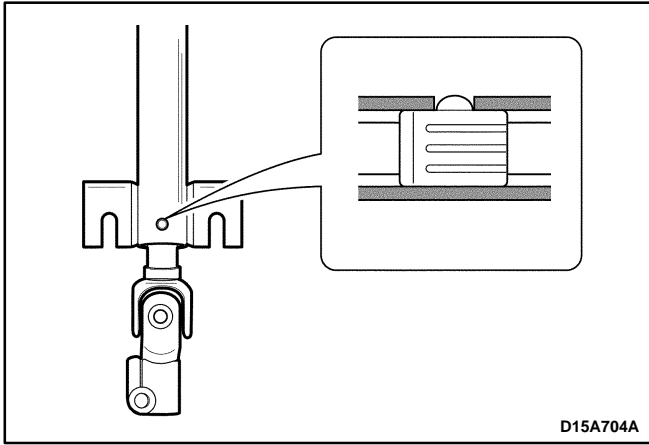

Assembly Procedure

Important: Position the alignment spacer on the lower column shaft to install the spacer in the steering column jacket easily.

1. Install the steering column shaft to the steering column.
 - Position the locking of the alignment spacer on the groove of the steering column.
 - Install the washer.
 - Install the spring.
 - Install the washer.
 - Install the retaining ring.
2. Install the steering column to the vehicle. Refer to "Steering Wheel" in this section.

SPECIFICATIONS

GENERAL SPECIFICATIONS

Application		Unit	Description
Steering Wheel	Diameter	With Airbag	mm (in.)
		Without Airbag	mm (in.)
	Free Play (Engine Stop)		mm (in.)

FASTENER TIGHTENING SPECIFICATIONS

Application	N•m	Lb-Ft	Lb-In
Steering Wheel Nut	23 – 33	17 – 24	–
Steering Column Upper Nuts	15 – 20	11 – 15	–
Steering Column Lower Nuts	15 – 20	11 – 15	–
Intermediate Shaft Upper Pinch Bolt	21 – 29	16 – 22	–
Intermediate Shaft Lower Pinch Bolt	21 – 29	16 – 22	–

SPECIAL TOOLS AND EQUIPMENT

SPECIAL TOOLS TABLE

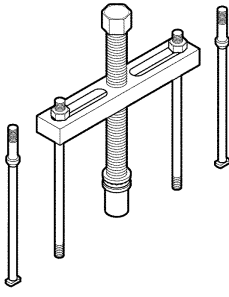
 <p>D105A101</p>	<p>DW310-010 Steering Wheel Puller</p>
---	--